

SNR self-locking precision nuts

**TB - TBR - TBP - TBPR series
and B - BR - BP - BPR series**

0.005 / A



SNR - Industry



SNR self-locking precision nuts



The self-locking precision nuts are assembly accessories that must be used in cases such as the following :

- When a preloading of the bearings package is required to guarantee the maintenance of the preloading time-value.
- When a high precision bearing assembly is being used, since this requires the use of accessories which will maintain the precision level of the equipment as a whole.
- When the setting of the position of the bearings package must be reliable and long-lasting, even when it is not preloaded (especially if the presence of significant axial efforts is foreseen during the operation of the equipment).



Overall, this type of nuts are used with ball bearings of angular contact (whether high precision or not), with cone bearings or with combined needle bearings.

Due to the high operating precision of these accessories, it is recommendable to replace them whenever you replace the bearings. It is also necessary to check the conditions of these accessories due to an operation carried out on the equipment, at least whenever the nut has to be dismantled.

The self-locking precision nuts assure their position by means of two or four locking elements. These elements are grafts of softer material than steel, that are mechanized during the same operation as that of the interior thread of the nut and are then fitted into the thread of the axle. Nevertheless, this does not modify the perpendicularity of the lateral face of the nut in relation to the axle of the nut. The grafts are fixed to head screws with an inside hexagon, centered on these elements.

Unlocking momentum and breaking axial load

The unlocking momentum **Md**, which is shown on the dimension tables for each type and size of nut is the power needed to apply to loosen this self-locking nut when it has been assembled previously by means of a tightening momentum **Ma**, and fixed via the tightening of the locking elements against the axle with a maximum tightening power of these elements **Mbl**, as shown in the tables.

The breaking axial load **Far**, also shown in the dimension tables, is the axial load which if applied to the nut will produce the breakage of the thread when it is assembled on an axle with a nut tolerance of 60. While operating, the maximum axial load which a nut can bear must be 75 % of the breaking axial load **Far**, defined for such a nut.

Precision

The thread and the flat side of the nut which leans against the bearing are built in the same fixation by which a high precision perpendicularity is obtained: 0.005 millimeter tolerance.

The thread is in accordance with the rules ISO R/724 with a 5H tolerance and in accordance with ISO 965/1.

Assembly precautions

Since we are dealing with a high precision element, the nuts must not be unwrapped until they are going to be used in order to avoid possible mechanical damage or dirt in the thread or on the push side.

They must lean on the covered side of the polished surface.

Once the thread is tightened with a spanner wrench (DIN 1810A and DIN 1810B), the fixation screws of the locking elements are tightened by the use of an Allen wrench (for series containing four grafts, tightening these progressively crosswise).

SNR features a wide range of wrenches especially designed for your requirements.

Blind hole series

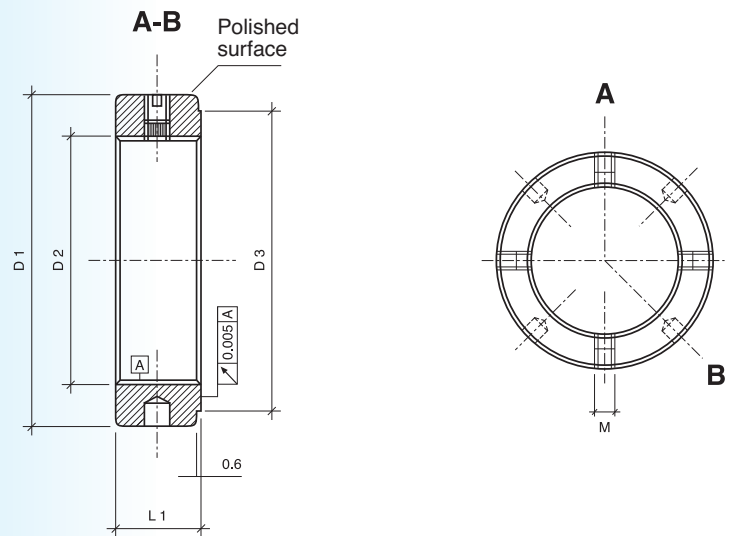

Crenel series

The SNR precision nuts range features a complementary "crenel" line. The difference with a common precision nut is in the way of locking it: with crenels instead of blind holes. Part numbers of these new products are detailed in tables hereafter.

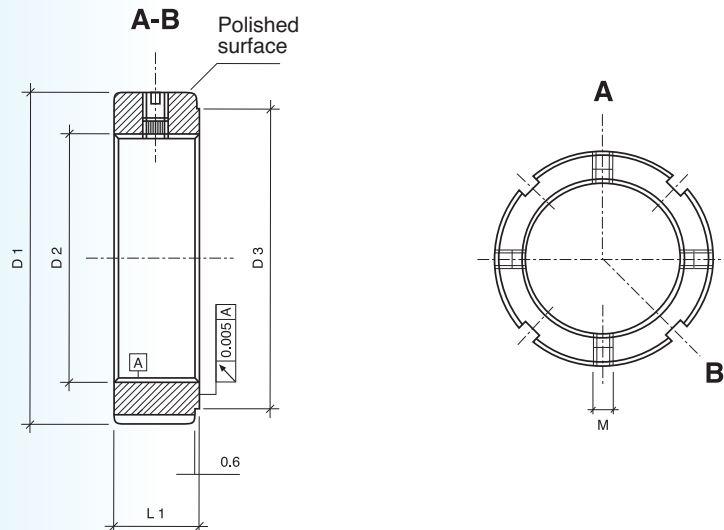

Correspondance between precision nut range versions

Crenel series	Blind hole series	Section	Number of inserts	Thread diameter	Material	Strength	Use
B	TB	Narrow	2	From 20 to 100 mm	High resistance polished steel	1 000 N/mm ²	Normal use
BR	TBR		4				Average performance maximum flatness demand
BP	TBP	Wide	2				High performance
BPR	TBPR		4				Very high performance maximum flatness demand

The information contained in this document is offered as an indication. It doesn't constitute any contractual commitment and can be modified without previous notice in advance.

BR and TBR type nuts

Thread	Reference		Weight	Dimensions				Fixation screws	Nut		
				D1	L1	D3	M		Mbl	Far	Ma
D2			kg	mm	mm	mm	mm	N.m	kN	N.m	N.m
M25x1.5	BR 25	TBR 25	0.06	38	12	33	M5	3-4	198	25	85
M30x1.5	BR 30	TBR 30	0.08	45	12	40	M5	3-4	240	32	96
M35x1.5	BR 35	TBR 35	0.11	52	12	47	M5	3-4	263	40	107
M40x1.5	BR 40	TBR 40	0.15	58	14	52	M6	6-8	290	55	127
M45x1.5	BR 45	TBR 45	0.18	65	14	59	M6	6-8	322	65	149
M50x1.5	BR 50	TBR 50	0.20	70	14	64	M6	6-8	351	85	180
M55x2	BR 55	TBR 55	0.25	75	16	68	M8	12-14	378	95	206
M60x2	BR 60	TBR 60	0.27	80	16	73	M8	12-14	405	100	255
M65x2	BR 65	TBR 65	0.28	85	16	78	M8	12-14	431	120	277
M70x2	BR 70	TBR 70	0.38	92	18	85	M8	12-14	468	130	304
M75x2	BR 75	TBR 75	0.42	98	18	90	M8	12-14	497	150	357
M80x2	BR 80	TBR 80	0.49	105	18	95	M8	12-14	527	160	396
M85x2	BR 85	TBR 85	0.52	110	18	100	M8	12-14	558	190	444
M90x2	BR 90	TBR 90	0.75	120	20	110	M8	12-14	603	200	501
M95x2	BR 95	TBR 95	0.78	125	20	115	M8	12-14	637	220	550
M100x2	BR 100	TBR 100	0.82	130	20	120	M8	12-14	688	250	603

BPR and TBPR type nuts

Thread	Reference		Weight	Dimensions				Fixation screws	Nut		
				D1	L1	D3	M		Mbl	Far	Ma
D2			kg	mm	mm	mm	mm	N.m	kN	N.m	N.m
M20x1/38	BPR 20/1	TBPR 20/1	0.12	38	20	28	M5	3-4	255	18	56
M20x1.5/38	BPR 20/1.5	TBPR 20/1.5	0.12	38	20	28	M5	3-4	225	18	56
M25x1.5/45	BPR 25	TBPR 25	0.17	45	20	33	M6	6-8	405	25	85
M30x1.5/52	BPR 30	TBPR 30	0.24	52	22	40	M6	6-8	491	32	96
M35x1.5/58	BPR 35	TBPR 35	0.28	58	22	47	M6	6-8	560	40	107
M40x1.5/62	BPR 40	TBPR 40	0.29	62	22	52	M8	12-14	585	55	127
M45x1.5/68	BPR 45	TBPR 45	0.37	68	24	59	M8	12-14	641	65	149
M50x1.5/75	BPR 50	TBPR 50	0.46	75	25	64	M8	12-14	706	85	180
M55x2/88	BPR 55	TBPR 55	0.92	88	32	68	M8	12-14	940	95	206
M60x2/98	BPR 60	TBPR 60	1.14	98	32	73	M8	12-14	1,070	100	255
M65x2/105	BPR 65	TBPR 65	1.29	105	32	78	M8	12-14	1,155	120	277
M70x2/110	BPR 70	TBPR 70	1.49	110	35	85	M8	12-14	1,230	130	304
M75x2/125	BPR 75	TBPR 75	2.25	125	38	90	M10	24-26	1,300	150	357
M80x2/140	BPR 80	TBPR 80	2.97	140	38	95	M10	24-26	1,420	160	396
M85x2/150	BPR 85	TBPR 85	3.44	150	38	100	M10	24-26	1,510	190	444
M90x2/155	BPR 90	TBPR 90	3.59	155	38	110	M10	24-26	1,596	200	501
M95x2/160	BPR 95	TBPR 95	3.73	160	38	115	M10	24-26	1,656	220	550
M100x2/160	BPR 100	TBPR 100	3.70	160	40	120	M10	24-26	1,780	250	603

B and TB type nuts

Thread	Reference		Weight	Dimensions				Fixation screws	Nut		
				D1	L1	D3	M		Mbl	Far	Ma
D2			kg	mm	mm	mm	mm	N.m	kN	N.m	N.m
M20x1	B 20/1	TB 20/1	0.04	32	10	28	M5	4-5	140	18	39
M20x1.5	B 20/1.5	TB 20/1.5	0.04	32	10	28	M5	4-5	126	18	39
M25x1.5	B 25	TB 25	0.06	38	12	33	M5	4-5	198	25	56
M30x1.5	B 30	TB 30	0.08	45	12	40	M5	4-5	240	32	63
M35x1.5	B 35	TB 35	0.11	52	12	47	M5	4-5	263	40	72
M40x1.5	B 40	TB 40	0.15	58	14	52	M6	8-10	290	55	97
M45x1.5	B 45	TB 45	0.18	65	14	59	M6	8-10	322	65	115
M50x1.5	B 50	TB 50	0.20	70	14	64	M6	8-10	351	85	132
M55x2	B 55	TB 55	0.25	75	16	68	M8	16-18	378	95	148
M60x2	B 60	TB 60	0.27	80	16	73	M8	16-18	405	100	186
M65x2	B 65	TB 65	0.28	85	16	78	M8	16-18	431	120	196
M70x2	B 70	TB 70	0.38	92	18	85	M8	16-18	468	130	228
M75x2	B 75	TB 75	0.42	98	18	90	M8	16-18	497	150	255
M80x2	B 80	TB 80	0.49	105	18	95	M8	16-18	527	160	291
M85x2	B 85	TB 85	0.52	110	18	100	M8	16-18	558	190	315
M90x2	B 90	TB 90	0.75	120	20	110	M8	16-18	603	200	369
M95x2	B 95	TB 95	0.78	125	20	115	M8	16-18	637	220	391
M100x2	B 100	TB 100	0.82	130	20	120	M8	16-18	688	250	432

BP and TBP type nuts

Thread	Reference		Weight	Dimensions				Fixation screws	Nuts		
				D1	L1	D3	M		Mbl	Far	Ma
D2			kg	mm	mm	mm	mm	N.m	kN	N.m	N.m
M20x1/38	BP 20/1	TBP 20/1	0.12	38	20	28	M5	4-5	255	18	39
M20x1.5/38	BP 20/1.5	TBP 20/1.5	0.12	38	20	28	M5	4-5	225	18	39
M25x1.5/45	BP 25	TBP 25	0.17	45	20	33	M6	8-10	405	25	56
M30x1.5/52	BP 30	TBP 30	0.24	52	22	40	M6	8-10	491	32	63
M35x1.5/58	BP 35	TBP 35	0.28	58	22	47	M6	8-10	560	40	72
M40x1.5/62	BP 40	TBP 40	0.29	62	22	52	M8	16-18	585	55	97
M45x1.5/68	BP 45	TBP 45	0.37	68	24	59	M8	16-18	641	65	115
M50x1.5/75	BP 50	TBP 50	0.46	75	25	64	M8	16-18	706	85	132
M55x2/88	BP 55	TBP 55	0.92	88	32	68	M8	16-18	940	95	148
M60x2/98	BP 60	TBP 60	1.14	98	32	73	M8	16-18	1,070	100	186
M65x2/105	BP 65	TBP 65	1.29	105	32	78	M8	16-18	1,155	120	196
M70x2/110	BP 70	TBP 70	1.49	110	35	85	M8	16-18	1,230	130	228
M75x2/125	BP 75	TBP 75	2.25	125	38	90	M10	30-32	1,300	150	255
M80x2/140	BP 80	TBP 80	2.97	140	38	95	M10	30-32	1,420	160	291
M85x2/150	BP 85	TBP 85	3.44	150	38	100	M10	30-32	1,510	190	315
M90x2/155	BP 90	TBP 90	3.59	155	38	110	M10	30-32	1,596	200	369
M95x2/160	BP 95	TBP 95	3.73	160	38	115	M10	30-32	1,656	220	391
M100x2/160	BP 100	TBP 100	3.70	160	40	120	M10	30-32	1,780	250	432

Europe

FRANCE

SNR Paris 40, rue Jean Bleuzen
B.P. 49 Tél. 01 40 93 66 00
92174 Vanves Cedex Fax. 01 40 93 66 10

SNR Logistique 9, avenue Léon Harmel Tél. 01 46 11 66 50
92160 Antony Fax. 01 46 11 66 66

SNR Bordeaux 1, rue du Golf - B.P. 173 Tél. 05 56 34 69 80
33708 Merignac Cedex Fax. 05 56 34 69 81

SNR Lyon Europe* Le Florentin - 71, chemin Tél. 04 78 66 68 00
du Moulin Carron - B.P. 8 Fax. 04 78 66 68 20
69570 Dardilly

SNR Nancy Europe* 3, allée Forêt de la Reine Tél. 03 83 44 64 00
Parc technologique Brabois Fax. 03 83 44 02 31
54500 Vandœuvre

DEUTSCHLAND

SNR WÄLZLAGER GMBH www.snr.de
40472 Düsseldorf Wahlerstraße 6 Tél. (0211) 6 58 06-0
40437 Düsseldorf Fax. (0211) 6 58 88 86
Postfach 33 04 10

33719 Bielefeld Friedrich-Hagemann-Str.66 Tél. (0521) 9 24 00-0
33701 Bielefeld Fax. (0521) 9 24 00 90
Postfach 17 01 45

70597 Stuttgart Tränkestraße 7 Tél. (0711) 9 00 64-0
70574 Stuttgart Fax. (0711) 9 00 64 99
Postfach 70 04 16

UNITED KINGDOM

NADELLA UK www.nadella.uk.com
Coventry Progress close Tél. 24 7629 6900
Leofric Business Park Fax. 24 7629 6991
Binley - Coventry CV3 2TF

ITALIA

SNR Italia
Milano Via Keplero, 5 Tél. (02) 33 55 21
20019 Settimo Fax (02) 33 50 06 56
Milanese (MI)

Bologna Via E.Zago, 2/2 Tél. (051) 36 79 46
40128 Bologna (051) 36 29 78
Fax (051) 36 85 38

ESPAÑA

SNR Rodamientos Hispania
Madrid C/ Llanos de Jerez, 22 Tél. 91 671 89 13
Polígono Industrial Fax. 91 673 65 48
28820 Coslada

BELGIQUE

NADELLA
Bruxelles Langveldpark
Basteleusstraat 2-4-6 unit 9 Tél. 02 523 81 92
1600 Sint-Pieters-Leeuw Fax. 02 522 52 57

*EUROPE (Subsidiaries excepted)
SNR Nancy - Europe : Benelux - Suisse - Autriche
SNR Lyon - Europe : Other Countries Fax. 04 78 66 68 21

Amériques / Americas

USA

SNR Bearings USA www.snrbearings.com
Atlanta 4600 K Highlands Pkwy Tél. (770) 435-2818
Smyrna, G.A. 30082 (800) 232-1717
Fax. (800) 742-5215

AMERICA LATINA

SNR Argentina
Buenos Aires Viamonte 1145 - Piso 11 Tél. (54) 11-4 372-1272
1053 Buenos Aires Fax. (54) 11-4 372-0088

Autres pays / Other countries

SNR Intermondial (Overseas)

Anney 18, rue du Val-Vert Tél. (33) 4 50 65 96 00/01/02
74600 Seynod Fax. (33) 4 50 65 96 15
France

MAROC

SNR Maroc e-mail : snrroulements@snrmaroc.com
Casablanca 17, rue Buzancy Tél. (212) 02 2 241 530
Belvédère Fax. (212) 02 2 241 532
Casablanca 20300 (212) 02 2 241 542



Siège social : Rue des Usines - 74000 Anney - FRANCE

RCS Anney B 325821072 - Code NAF 291H

<http://www.snr.fr>