

SNR self-locking precision nuts

**TB - TBR - TBP - TBPR series
and B - BR - BP - BPR series**

0.005 / A



SNR - Industry



SNR self-locking precision nuts



Self-locking precision nuts are assembly accessories that must be used in the following circumstances :

- To maintain the original preload value throughout the service life of a preloaded bearing assembly.
- To maintain the high level of precision of a mechanism that uses high precision bearings and components.
- To ensure the axial retention of a bearing assembly, even when not preloaded, and especially when the assembly is subject to heavy thrust loads during operation.

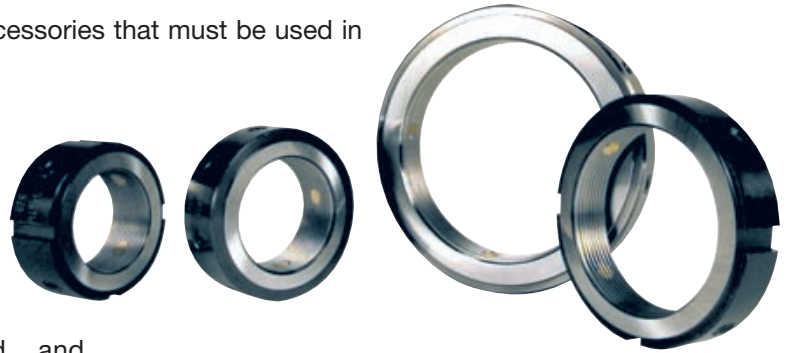

Typically, this type of locknut is selected for use with angular-contact ball bearings (standard or high precision), tapered roller bearings or combined radial-thrust needle bearings.

Since these accessories are manufactured with very tight tolerances, we recommend they be replaced each time bearings are changed, or at least carefully inspected whenever a maintenance operation that requires their removal is performed.

The retention of the self-locking precision nuts is assured by two or four locking components. These components, which are inserts made of softer material than steel, are machined concurrently with the thread tapping operation. Full retention of these nuts is achieved by driving the inserts into the threads of the shaft. This operation does not change the squareness of the bearing face of these nuts to the pitch diameter of the threads. Inserts are pushed in place by tightening hex-head screws that are centered on top of these components.

Releasing torque and rupture thrust load

The releasing torque **M_d**, listed in the tables for each type and size of nut, is the minimum torque required to loosen the corresponding self-locking nut that was originally set with a torque **M_a**, and locked on the shaft by driving the inserts into the shaft with a tightening torque **M_{b1}**.

The rupture thrust load **F_{ar}**, also listed in the tables, is the thrust load that, if applied to a self-locking nut that is set on a shaft with a thread tolerance of 6G, causes the nut threads to rupture. In operation, the maximum thrust load applied to a nut should not exceed 75 % of its rupture thrust load.

Precision

Threads and the bearing face of the SNR self-locking nuts are machined in the same fixture. This process guarantees the tolerance of the bearing face to pitch diameter of threads of the nut to be within 0.005 millimeters (.0002 inches).

Threads are metric and conform to the ISO standard R/724. They are designed with a 5H tolerance per the ISO standard 965/1.

Recommendations for installation

Since a self-locking nut is a high precision component, do not remove it from its original packing until just before it is to be fitted. The packing protects the nut against potential handling damage and contamination of the thread or the bearing face.

If unpacked, always rest the nut on its black oxide face (opposite to the shiny ground bearing face).

After tightening the nut with a spanner wrench (DIN 1810A and DIN 1810B), use an Allen wrench to tighten the hex-head screws that drive the locking inserts into the threads (for series containing four inserts, tighten these screws progressively crosswise).

SNR features a wide range of wrenches especially designed for your requirements.

Blind hole series

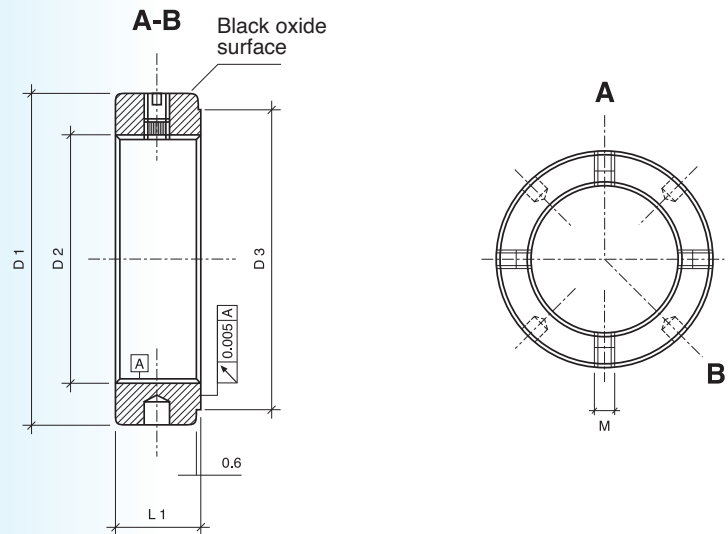

Crenel series

The SNR precision nuts range features a complementary "crenel" line. The difference with a common precision nut is in the way of locking it: with crenels instead of blind holes. Part numbers of these new products are detailed in tables hereafter.

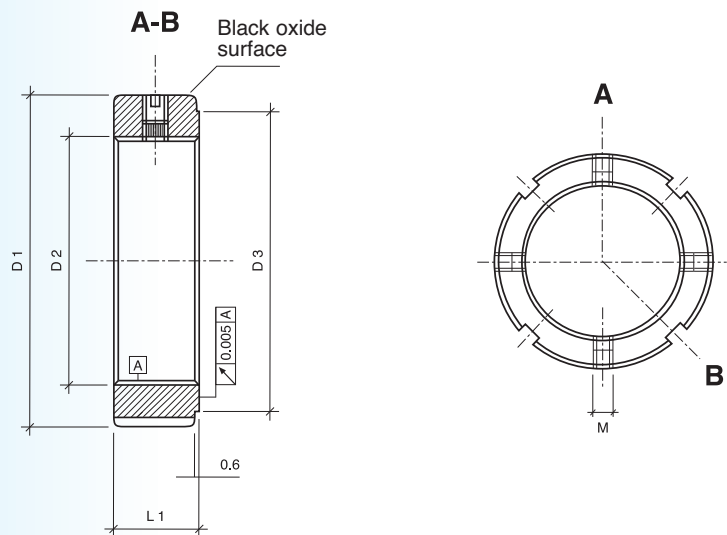

Correspondance between precision nut range versions

Crenel series	Blind hole series	Section	Number of inserts	Thread diameter	Material	Strength	Application
B	TB	Narrow	2	From 20 to 100 mm	High resistance dark oxide steel	1,000 N/mm ² (145,000 Psi)	Normal usage
BR	TBR		4				Average loads, maximum flatness requirements
BP	TBP	Wide	2				Heavy loads
BPR	TBPR		4				Very heavy loads, maximum flatness requirements

Data contained in this document are for information only and may not be used as part of a contractual warrantee. They can be modified at any time without notice.

BR and TBR type nuts

Thread	Part number		Weight	Dimensions				Locking screw	Nut		
				D1	L1	D3	M		Mbl	Far	Ma
D2			lb	mm	mm	mm	mm	ft.lbf	1,000 lbf	ft.lbf	ft.lbf
M25x1.5	BR 25	TBR 25	0.13	38	12	33	M5	2.2-3	44.5	18	63
M30x1.5	BR 30	TBR 30	0.18	45	12	40	M5	2.2-3	54.0	24	71
M35x1.5	BR 35	TBR 35	0.23	52	12	47	M5	2.2-3	59.1	30	79
M40x1.5	BR 40	TBR 40	0.32	58	14	52	M6	4.4-6	65.2	41	94
M45x1.5	BR 45	TBR 45	0.40	65	14	59	M6	4.4-6	72.4	48	110
M50x1.5	BR 50	TBR 50	0.44	70	14	64	M6	4.4-6	78.9	63	133
M55x2	BR 55	TBR 55	0.54	75	16	68	M8	8.9-10.3	85.0	70	152
M60x2	BR 60	TBR 60	0.59	80	16	73	M8	8.9-10.3	91.0	74	188
M65x2	BR 65	TBR 65	0.63	85	16	78	M8	8.9-10.3	96.9	89	204
M70x2	BR 70	TBR 70	0.84	92	18	85	M8	8.9-10.3	105.2	96	224
M75x2	BR 75	TBR 75	0.94	98	18	90	M8	8.9-10.3	111.7	111	263
M80x2	BR 80	TBR 80	1.09	105	18	95	M8	8.9-10.3	118.5	118	292
M85x2	BR 85	TBR 85	1.15	110	18	100	M8	8.9-10.3	125.4	140	327
M90x2	BR 90	TBR 90	1.65	120	20	110	M8	8.9-10.3	135.6	148	370
M95x2	BR 95	TBR 95	1.72	125	20	115	M8	8.9-10.3	143.2	162	406
M100x2	BR 100	TBR 100	1.80	130	20	120	M8	8.9-10.3	154.7	184	445

BPR and TBPR type nuts

Thread	Part number		Weight	Dimensions				Locking screw	Nut		
				D1	L1	D3	M		Mbl	Far	Ma
D2			lb	mm	mm	mm	mm	ft.lbf	1,000 lbf	ft.lbf	ft.lbf
M20x1/38	BPR 20/1	TBPR 20/1	0.27	38	20	28	M5	2.2-3	57.3	13	41
M20x1.5/38	BPR 20/1.5	TBPR 20/1.5	0.27	38	20	28	M5	2.2-3	50.6	13	41
M25x1.5/45	BPR 25	TBPR 25	0.37	45	20	33	M6	4.4-6	91.0	18	63
M30x1.5/52	BPR 30	TBPR 30	0.52	52	22	40	M6	4.4-6	110.4	24	71
M35x1.5/58	BPR 35	TBPR 35	0.61	58	22	47	M6	4.4-6	125.9	30	79
M40x1.5/62	BPR 40	TBPR 40	0.65	62	22	52	M8	8.9-10.3	131.5	41	94
M45x1.5/68	BPR 45	TBPR 45	0.82	68	24	59	M8	8.9-10.3	144.1	48	110
M50x1.5/75	BPR 50	TBPR 50	1.02	75	25	64	M8	8.9-10.3	158.7	63	133
M55x2/88	BPR 55	TBPR 55	2.03	88	32	68	M8	8.9-10.3	211.3	70	152
M60x2/98	BPR 60	TBPR 60	2.51	98	32	73	M8	8.9-10.3	240.5	74	188
M65x2/105	BPR 65	TBPR 65	2.84	105	32	78	M8	8.9-10.3	259.6	89	204
M70x2/110	BPR 70	TBPR 70	3.29	110	35	85	M8	8.9-10.3	276.5	96	224
M75x2/125	BPR 75	TBPR 75	4.97	125	38	90	M10	17.7-19.2	292.2	111	263
M80x2/140	BPR 80	TBPR 80	6.55	140	38	95	M10	17.7-19.2	319.2	118	292
M85x2/150	BPR 85	TBPR 85	7.58	150	38	100	M10	17.7-19.2	339.4	140	327
M90x2/155	BPR 90	TBPR 90	7.91	155	38	110	M10	17.7-19.2	358.8	148	370
M95x2/160	BPR 95	TBPR 95	8.23	160	38	115	M10	17.7-19.2	372.3	162	409
M100x2/160	BPR 100	TBPR 100	8.15	160	40	120	M10	17.7-19.2	400.1	184	445

B and TB type nuts

Thread	Part number		Weight	Dimensions				Locking screw	Nut		
				D1	L1	D3	M		Mbl	Far	Ma
D2			lb	mm	mm	mm	mm	ft.lbf	1,000 lbf	ft.lbf	ft.lbf
M20x1	B 20/1	TB 20/1	0.08	32	10	28	M5	3-3.7	31.5	13	29
M20x1.5	B 20/1.5	TB 20/1.5	0.08	32	10	28	M5	3-3.7	28.3	13	29
M25x1.5	B 25	TB 25	0.13	38	12	33	M5	3-3.7	44.5	18	41
M30x1.5	B 30	TB 30	0.18	45	12	40	M5	3-3.7	54.0	24	46
M35x1.5	B 35	TB 35	0.23	52	12	47	M5	3-3.7	59.1	30	53
M40x1.5	B 40	TB 40	0.33	58	14	52	M6	6-7.4	65.2	41	72
M45x1.5	B 45	TB 45	0.41	65	14	59	M6	6-7.4	72.4	48	85
M50x1.5	B 50	TB 50	0.44	70	14	64	M6	6-7.4	78.9	63	97
M55x2	B 55	TB 55	0.55	75	16	68	M8	12-13.3	85.0	70	109
M60x2	B 60	TB 60	0.59	80	16	73	M8	12-13.3	91.0	74	137
M65x2	B 65	TB 65	0.63	85	16	78	M8	12-13.3	96.9	89	145
M70x2	B 70	TB 70	0.84	92	18	85	M8	12-13.3	105.2	96	168
M75x2	B 75	TB 75	0.94	98	18	90	M8	12-13.3	111.7	111	188
M80x2	B 80	TB 80	1.10	105	18	95	M8	12-13.3	118.5	118	215
M85x2	B 85	TB 85	1.15	110	18	100	M8	12-13.3	125.4	140	232
M90x2	B 90	TB 90	1.66	120	20	110	M8	12-13.3	135.6	148	272
M95x2	B 95	TB 95	1.74	125	20	115	M8	12-13.3	143.2	162	288
M100x2	B 100	TB 100	1.82	130	20	120	M8	12-13.3	154.7	184	319

BP and TBP type nuts

Thread	Part number		Weight	Dimensions				Locking screw	Nut		
				D1	L1	D3	M		Mbl	Far	Ma
D2			lb	mm	mm	mm	mm	ft.lbf	1,000 lbf	ft.lbf	ft.lbf
M20x1/38	BP 20/1	TBP 20/1	0.27	38	20	28	M5	3-3.7	83.8	44	62
M20x1.5/38	BP 20/1.5	TBP 20/1.5	0.27	38	20	28	M5	3-3.7	83.8	44	62
M25x1.5/45	BP 25	TBP 25	0.37	45	20	33	M6	6-7.4	99.2	44	73
M30x1.5/52	BP 30	TBP 30	0.52	52	22	40	M6	6-7.4	114.6	49	88
M35x1.5/58	BP 35	TBP 35	0.61	58	22	47	M6	6-7.4	127.9	49	104
M40x1.5/62	BP 40	TBP 40	0.65	62	22	52	M8	12-13.3	136.7	49	115
M45x1.5/68	BP 45	TBP 45	0.82	68	24	59	M8	12-13.3	149.9	53	130
M50x1.5/75	BP 50	TBP 50	1.02	75	25	64	M8	12-13.3	165.3	55	141
M55x2/88	BP 55	TBP 55	2.03	88	32	68	M8	12-13.3	216.1	71	150
M60x2/98	BP 60	TBP 60	2.51	98	32	73	M8	12-13.3	216.1	71	161
M65x2/105	BP 65	TBP 65	2.84	105	32	78	M8	12-13.3	231.5	71	172
M70x2/110	BP 70	TBP 70	3.29	110	35	85	M8	12-13.3	242.5	77	187
M75x2/125	BP 75	TBP 75	4.97	125	38	90	M10	22-23.6	275.6	84	198
M80x2/140	BP 80	TBP 80	6.55	140	38	95	M10	22-23.6	308.6	84	209
M85x2/150	BP 85	TBP 85	7.58	150	38	100	M10	22-23.6	330.7	84	220
M90x2/155	BP 90	TBP 90	7.91	155	38	110	M10	22-23.6	341.7	84	243
M95x2/160	BP 95	TBP 95	8.23	160	38	115	M10	22-23.6	352.7	84	254
M100x2/160	BP 100	TBP 100	8.15	160	40	120	M10	22-23.6	352.7	88	265

Europe

FRANCE

SNR Paris 40, rue Jean Bleuzen
B.P. 49 Tél. 01 40 93 66 00
92174 Vanves Cedex Fax 01 40 93 66 10

SNR Logistique 9, avenue Léon Harmel Tél. 01 46 11 66 50
92160 Antony Fax 01 46 11 66 66

SNR Bordeaux 1, rue du Golf - B.P. 173 Tél. 05 56 34 69 80
33708 Merignac Cedex Fax 05 56 34 69 81

SNR Lyon Europe* Le Florentin - 71, chemin Tél. 04 78 66 68 00
du Moulin Carron - B.P. 8 Fax 04 78 66 68 20
69570 Dardilly

SNR Nancy Europe* 3, allée Forêt de la Reine Tél. 03 83 44 64 00
Parc technologique Brabois Fax 03 83 44 02 31
54500 Vandœuvre

DEUTSCHLAND

SNR WÄLZLAGER GMBH www.snr.de
40472 Düsseldorf Wahlerstraße 6 Tél. (0211) 6 58 06-0
40437 Düsseldorf Fax (0211) 6 58 88 86
Postfach 33 04 10

33719 Bielefeld Friedrich-Hagemann-Str.66 Tél. (0521) 9 24 00-0
33701 Bielefeld Fax (0521) 9 24 00 90
Postfach 17 01 45

70597 Stuttgart Tränkestraße 7 Tél. (0711) 9 00 64-0
70574 Stuttgart Fax (0711) 9 00 64 99
Postfach 70 04 16

UNITED KINGDOM

NADELLA UK www.nadella.uk.com
Coventry Progress close Tél. 24 7629 6900
Leofric Business Park Fax 24 7629 6991
Binley - Coventry CV3 2TF

ITALIA

SNR Italia
Milano Via Keplero, 5 Tél. (02) 33 55 21
20019 Settimo Fax (02) 33 50 06 56
Milanese (MI)

Bologna Via E. Zago, 2/2 Tél. (051) 36 79 46
40128 Bologna (051) 36 29 78
Fax (051) 36 85 38

ESPAÑA

SNR Rodamientos Hispania
Madrid C/ Llanos de Jerez, 22 Tél. 91 671 89 13
Poligono Industrial Fax 91 673 65 48
28820 Coslada

BELGIQUE

NADELLA
Bruxelles Langveldpark
Basteleusstraat 2-4-6 unit 9 Tél. 02 523 81 92
1600 Sint-Pieters-Leeuw Fax 02 522 52 57

*EUROPE

(Subsidiaries excepted)
SNR Nancy - Europe : Benelux - Suisse - Autriche
SNR Lyon - Europe : Other Countries Fax 04 78 66 68 21

Amériques / Americas

USA

SNR Bearings USA www.snrbearings.com
Atlanta 4600 K Highlands Pkwy Tél. (770) 435-2818
Smyrna, G.A. 30082 (800) 232-1717
Fax (800) 742-5215

AMERICA LATINA

SNR Argentina
Buenos-Aires Viamonte 1145 - Piso 11 Tél. (54) 11-4 372-1272
1053 Buenos Aires Fax (54) 11-4 372-0088

Autres pays / Other countries

SNR Intermondial (Overseas)

Anney 18, rue du Val-Vert Tél. (33) 4 50 65 96 00/01/02
74600 Seynod Fax (33) 4 50 65 96 15
France

MAROC

SNR Maroc e-mail : snrroulements@snrmaroc.com
Casablanca 17, rue Buzancy Tél. (212) 02 2 241 530
Belvédère Fax (212) 02 2 241 532
Casablanca 20300 (212) 02 2 241 542



Siège social : Rue des Usines - 74000 Anney - FRANCE

RCS Anney B 325821072 - Code NAF 291H

<http://www.snr.fr>