



# DPF357.06

## Part details

Some vehicle applications that use vibration damper pulley DPF357.06 require a special diamond washer to be fitted.

### Which vehicles require the diamond washer ?

The washer is used on : Audi A6, VW Crafter, VW Transporter T4, Volvo 850, S70, S80, V70 I, V70 II

### What is the purpose of the diamond washer?

**The diamond coated washer sits between the crankshaft pulley and the timing belt pulley.**

The washer along with the centre retaining bolt prevent the vibration damper pulley (DPF357.06) from working itself loose.



**It is important that the diamond washer is fitted to ensure that the timing pulley and vibration damper pulley do not work loose. The diamond washer and bolts supplied with SNR kits, should always be used and torqued to the manufactures torque settings.**

### KITS SUPPLIED WITH THE DIAMOND WASHER

The diamond washer is supplied in NTN SNR kits DPF357.06K1 and DPF357.06K2.

If an old vibration damper pulley or replacement pulley is going to be fitted it is recommended that the washer and centre retaining stretch bolt are both replaced.

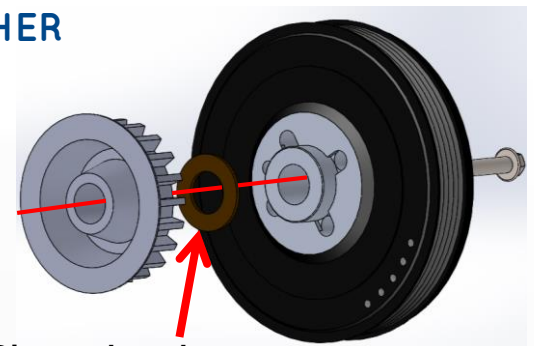

**Diamond washer**



Scan this QR code to access our online catalogue.

**FOLLOW THE RECOMMENDATIONS OF THE VEHICLE MANUFACTURER.**