



Brand of **NTN Group**

LINEAR GUIDES

High-performance products
for all applications



INNOVATION DRIVING YOUR PRODUCTION

Movement. It is constantly changing. It is analysed, brought under control, guided and mastered with the aim of deriving maximum benefit. It is more than merely a concept. It is the very essence of our commitment, namely designing and innovating to deliver the perfect solutions to the issues and constraints of today and tomorrow.

There are thousands of us around the world masterminding and developing solutions to raise the bar on your production performance. Our world-leading brands (NTN, BCA, BOWER and SNR) are marketed worldwide and deliver the best-fit solutions for working together and building a more environmentally-friendly society. Follow our lead and use interaction, anticipation and adaptation as the keys to guiding and shaping the future of the manufacturing, automotive and aviation markets.

€ 5.5 BILLION
turnover*

23,000
employees*

The local service of an international partner



118
Sales
offices

73
Production
sites

15
R&D
centres

* as of March 2023

SNR Linear Guides are universally applicable machine elements that accommodate the steadily growing requirements for the automation of installation and manufacturing processes.

The SNR Linear Guides are used in many different applications, such as:

- Machine tool manufacture
- Packaging and printing machines
- Special and general engineering
- Aircraft construction
- Automation and assembly lines
- Wood and paper industry
- Semiconductor industry
- Medical engineering
- and much more



The different series are designed according to a modular principal.

Advantages:

- Linear Guides with ball chain and conventional versions
- One-rail geometry, i. e. all design heights, design types and versions at the same rail mountable
- Various sealing and greasing options
- Divided rails consist of arbitrary combinable segments
- Wide range of accessories

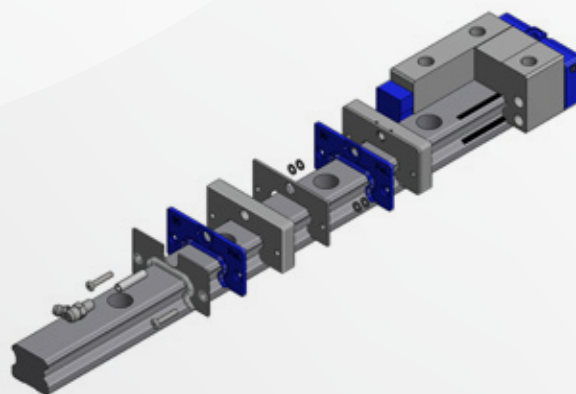

This technical catalogue provides an overview of our Linear Axis range and forms the basis of our discussions with you – our customer.



CONTENT

1	Basics of Linear Guides	6
1.1	Design principles	7
1.2	Ball chain technology	10
1.3	Characteristics	14
1.4	Selection criteria	15
2	System technology	16
2.1	Definitions	16
2.2	Standards	16
2.3	Intended use	17
2.4	Safety instructions	17
2.5	Coordinate system	18
2.6	Static safety	18
2.7	Service life time calculation	19
2.7.1	Influence factors	20
2.7.2	Acting load - equivalence factors	22
2.7.3	Equivalent loads	25
2.7.4	Calculation examples	28
2.8	Preload/rigidity	37
2.8.1	Preload classes	37
2.8.2	Rigidity	39
2.9	Precision	40
2.9.1	Precision classes	40
2.9.2	Interchangeability	42
2.9.3	Error compensation	42
2.10	Drive power	43
2.10.1	Friction	43
2.10.2	Driving resistance	44
2.10.3	Driving force	45

3	Installation	47		
3.1	Arrangement of the installation surface	47		
3.2	Marking of Linear Guides	49		
3.3	Arrangement of Linear Guides	50		
3.4	Installation position of Linear Guides	51		
3.5	Installation instructions	52		
3.6	Permitted installation tolerances	54		
3.7	Fastening torques	58		
4	Lubrication	59		
4.1.	General information	59		
4.2	Lubricants	59		
4.2.1	Anti-corrosion oils	60		
4.2.2	Lubrication oils	60		
4.2.3	Low-viscosity greases	61		
4.2.4	Lubrication greases	62		
4.3.	Lubrication methods	63		
4.4	Lubricant volumes	64		
4.5	Lubrication intervals	66		
5	SNR Linear Guides	68		
5.1	Overview	68		
5.2	LGBCH_F	70		
5.3	LGBCS_F	72		
5.4	LGBCH_B / LGBCX_B	74		
5.5	LGBCS_B	76		
5.6	LGBXH_F	78		
5.7	LGBXS_F	80		
5.8	LGBXH_B / LGBXX_B	82		
5.9	LGBXS_B	84		
5.10	LGBXH_TN	86		
5.11	LGBXH_WN	88		
5.12	LGMC...B	90		
5.13	LGMC_W	92		
5.14	LGMX_B	94		
5.15	LGMX_W	96		
5.16	Standard rail length	98		
5.17	Rail arrangement	99		
6	Accessories	100		
6.1	Sealing Options	100		
6.1.1	Description	100		
6.1.2	Combination options	101		
6.1.3	Dimensions	103		
6.2	Rail caps	104		
6.3	Bellows	105		
6.3.1	Dimensions	105		
6.3.2	Assembly of bellows	105		
6.3.3	Designation	106		
6.4	Cover strip	106		
6.4.1	Dimension	106		
6.4.2	Mounting tool	106		
6.4.3	Designation	106		
6.5	Clamping and braking elements	107		
6.5.1	Manual clamping element	107		
6.5.2	Pneumatic clamping element	109		
6.5.3	Pneumatic clamping and braking elements	114		
6.5.4	Hydraulic clamping elements	116		
6.6	Lubrication options	117		
6.6.1	Lubrication system LU1	117		
6.6.2	Lubrication connections	118		
6.6.3	Lubrication adapter	124		
6.6.4	Grease guns	125		
6.6.5	Central lubrication systems	126		
7	Corrosion protection	127		
8	Type code	128		
9	Type list	132		
10	Guide to queries	133		
11	Index	135		

1 Basics of Linear Guides

Man has moved heavy loads since ancient times using rotation and linear movement or a combination of both. These movements are still found in many machines. The friction bearings initially used have mostly been replaced by roller bearings. Rolling elements in machines were established more than a hundred years ago, while rolling elements for linear movements have only become common in the last few decades.

Figure 1.1 Movement of heavy loads

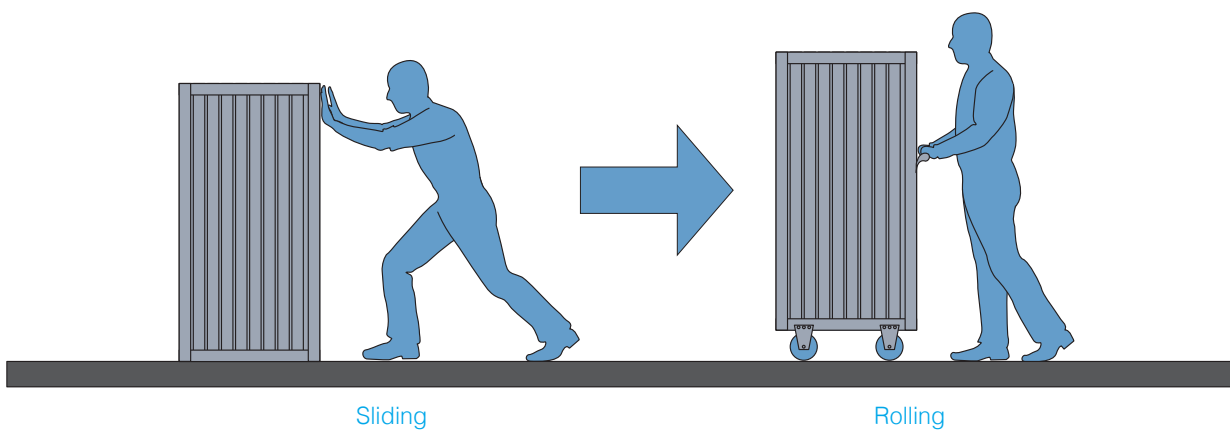

1.1 Design principles

High surface pressure results when a ball touches a flat surface at one point (Figure 1.2). Grooves in modern Linear Guides are manufactured with a defined radius to increase the contact area. The ratio of the race way radius to the ball diameter in percent is called osculation. This significantly increases the load capacity, service life time and rigidity of the balls for equal surface pressure.

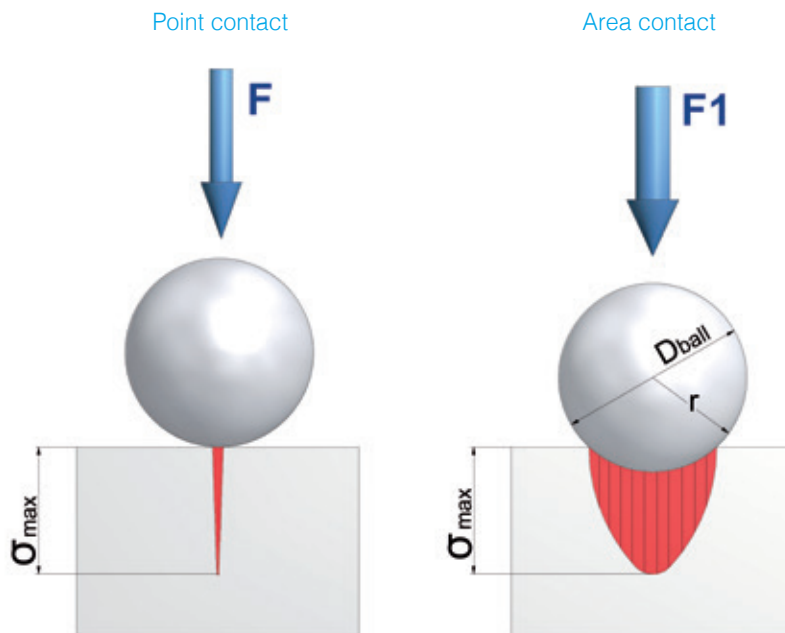

Figure 1.2 SNR Linear Guides

- δ_{max} maximum surface pressure
- D_{ball} Ball diameter
- r Race way radius

There are two basic design principles for Linear Guides with balls as rolling elements - circular arc grooves and Gothic arc grooves (Figure 1.3).

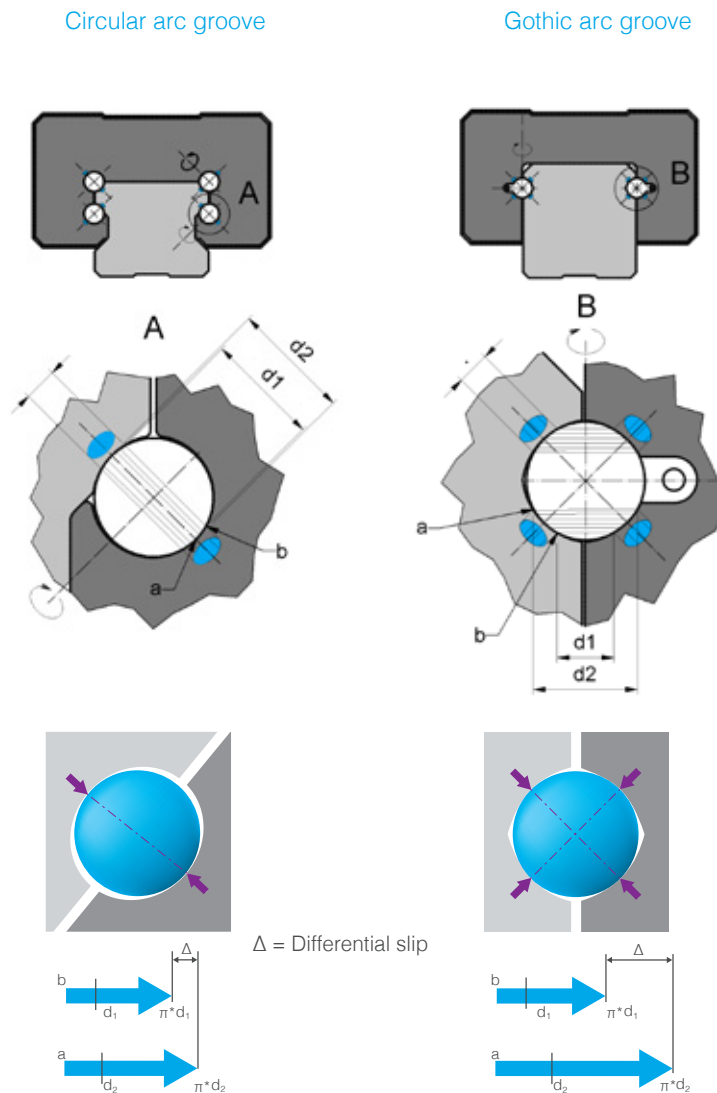
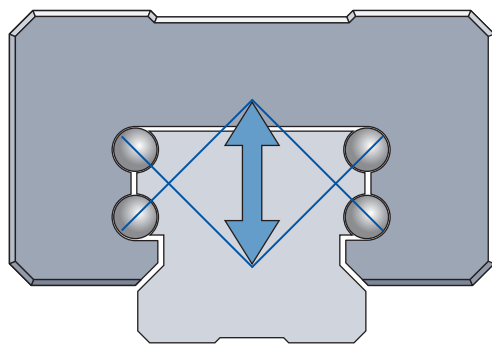

Figure 1.3 Race way geometry

Circular arc grooves have one contact surface on the profile rail and one on the carriage. This creates 2-point contact. The special shape of the Gothic-arc groove creates two contact surfaces on the profile rail and two on the carriage, resulting in 4-point contact with the rolling element. A detailed view of the rolling elements shows that differential slip results from the difference between contact diameters d_1 and d_2 . The differential slip is significantly greater for arrangements with Gothic arc grooves than for circular arc grooves. This leads to a higher friction coefficient, higher driving resistance, higher wear and higher energy consumption. Our standard Linear Guides therefore all have circular arc grooves. The geometry of the Gothic arc groove is only used for miniature Linear Guides, for the compactness of its design.

The race way configuration is another characteristic of Linear Guides. The following alternatives are used: DF-configuration and DB-configuration of the race ways, corresponding to the terms used for roller bearing systems (Figure 1.4).



Linear Guide with DF-configuration

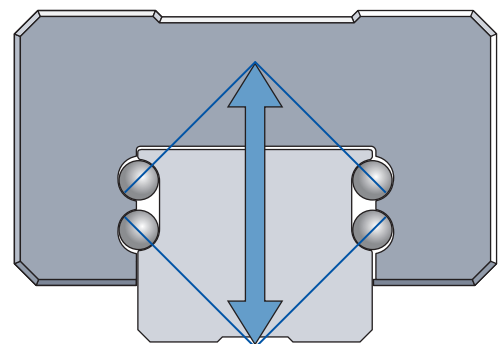

Linear Guides with DB-configuration

Figure 1.4 - DF- and DB-configuration

Linear Guide systems can be exposed to torque stress resulting from assembling errors (Figure 1.5). When the distance between the active points is low, the resulting internal loads is low as well. The SNR Linear Guides are therefore produced using the DF-configuration

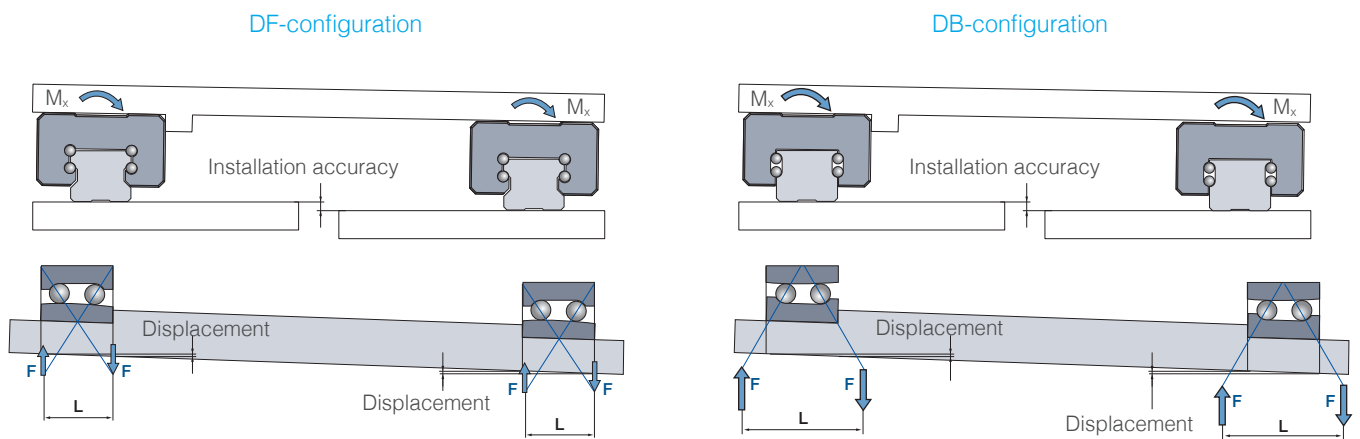

Figure 1.5 Internal forces for DF- and DB-configuration

The most important characteristics of SNR Linear Guides are therefore:

- Wider permitted assembling errors
- Very good self-adjustment properties
- Lower costs for manufacture and preparation of the mounting surfaces

1.2 Ball chain technology

Cages for guiding the rolling elements, which have been used for over 100 years in roller bearings, are also part of the newly developed Linear Guides. Linear Guides with ball chains differ from conventional series in the following characteristics:

- Higher dynamic load rating
- Less heat generation
- Less noise generation
- Very smooth running
- Optimised lubrication system
- Even load distribution
- Longer service life

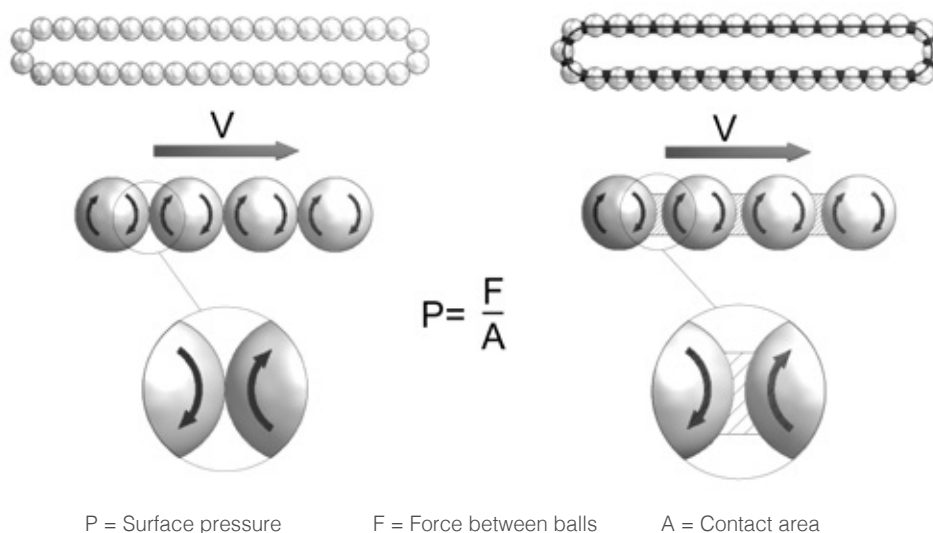

Figure 1.6 Contact areas

The rotating balls in conventional Linear Guides have point contact between each other (Figure 1.6). The rotation speed at the contact point is double that of the speed of the balls. The contact area (A) is so small that the surface pressure (P) tends towards infinity. This leads to heating and wear of the balls and the Linear Guides system. The chain in Linear Guides with ball chains has the function of a cage. Contact between the balls is prevented (Figure 1.6). The ball and the chain also have a relatively large contact area (A) that significantly reduces the surface pressure (P). The rotation speeds at the contact surfaces of ball and chain correspond. The ball chain is further used to transport the lubricant and to create a lubrication film on the balls. The design of the carriage allows effective supply with lubricant from the lubricant connection to the circulation areas of the ball chains (Figure 1.7).

Conventional Linear Guides allow contact between the balls during operation, which may lead to increased lubricant consumption, higher friction, noise and heat. Linear Guides with ball chain minimize these effects.

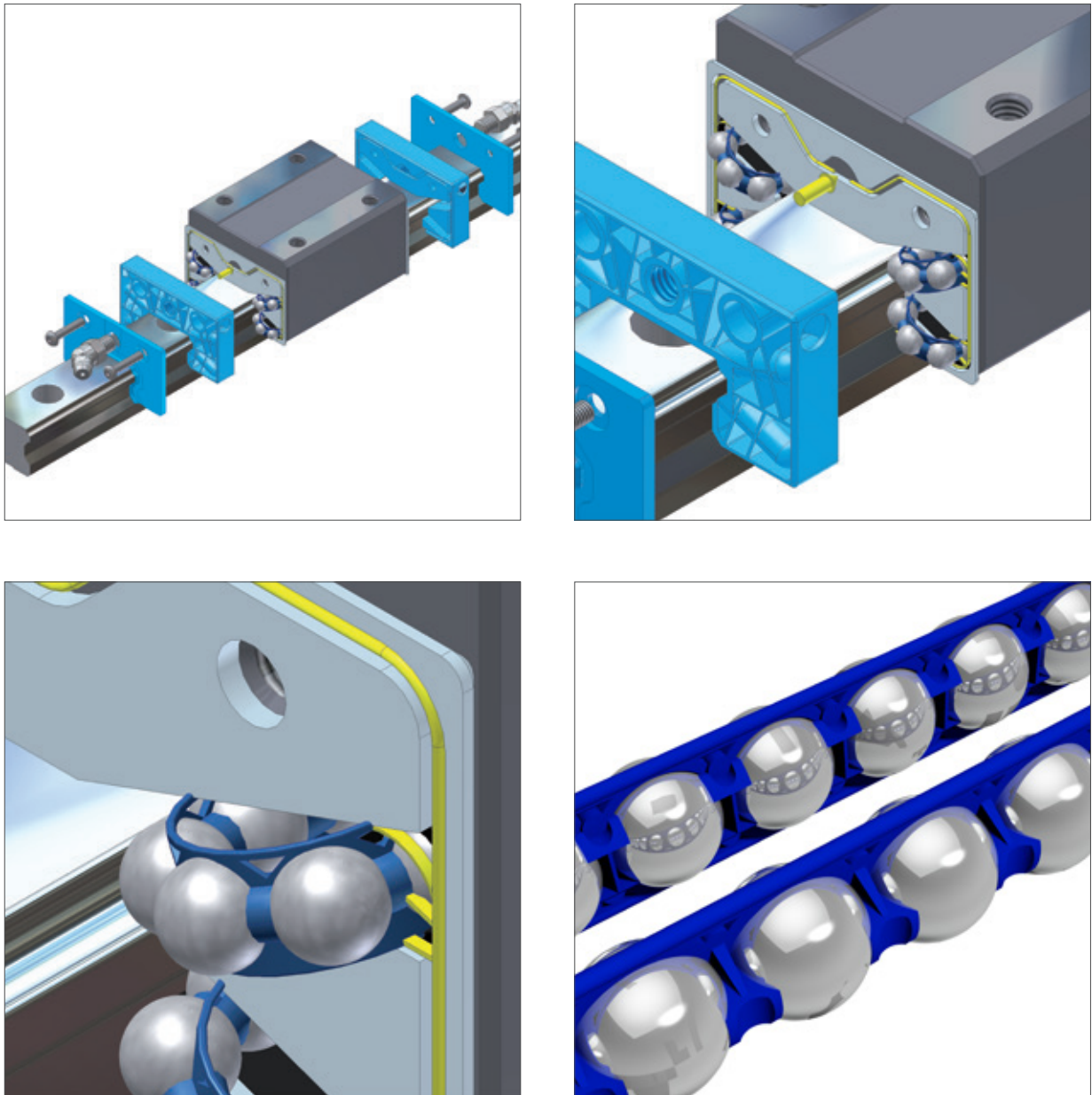

Figure 1.7 Linear Guides with ball chains

The noise generation of Linear Guides is mainly determined by their design. Direct knocking of balls against each other is the main reason for increased noise generation in conventional models. In addition, the contact of the balls with the surfaces of the re-circulating hole affects noise generation (Figure 1.8).

These effects are significantly reduced by the use of ball chains. The patented structure of the ball chain further contains gaps for lubricant depots. The combination of the flexibility of the ball chain and the lubricant acts like a buffer and significantly reduces the noise level (Figure 1.9).

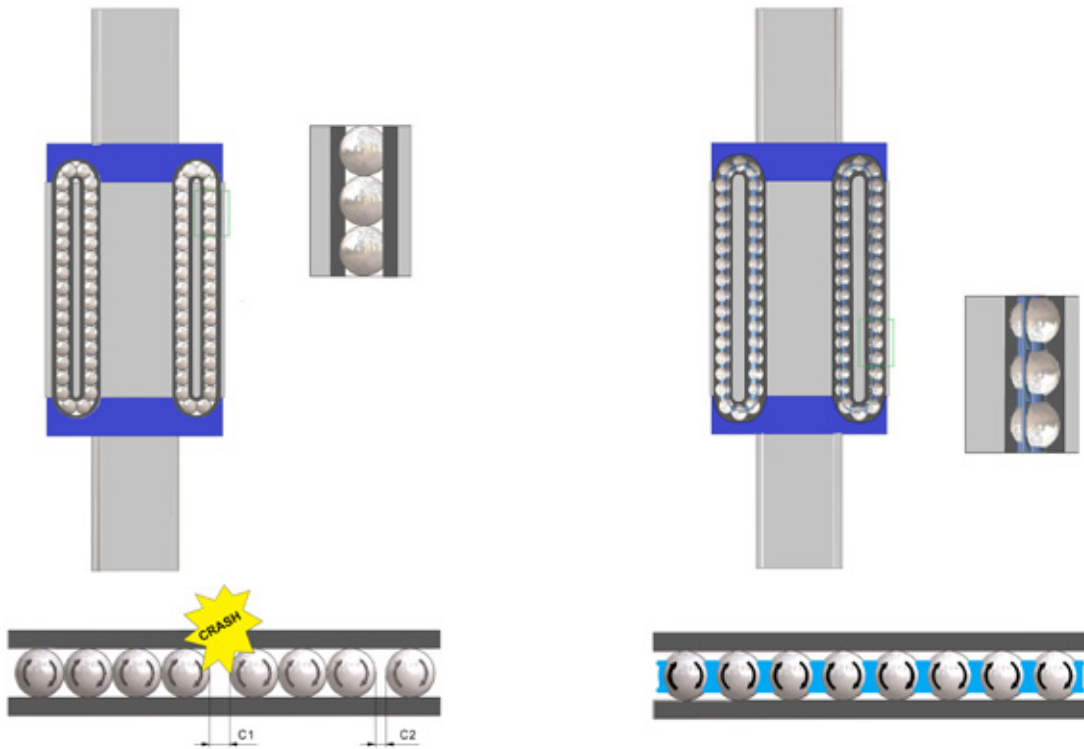

Figure 1.8 Comparison of the designs of Linear Guides

It is not possible to keep the distance of the balls (C1, C2) constant in conventional Linear Guides (Figure 1.8). These irregular distances between the balls lead to uneven running behaviour.

At the same time, the balls are continuously supplied with lubricant, which reduces wear of the metal. This significantly extends the service life of the lubricant and the maintenance intervals.

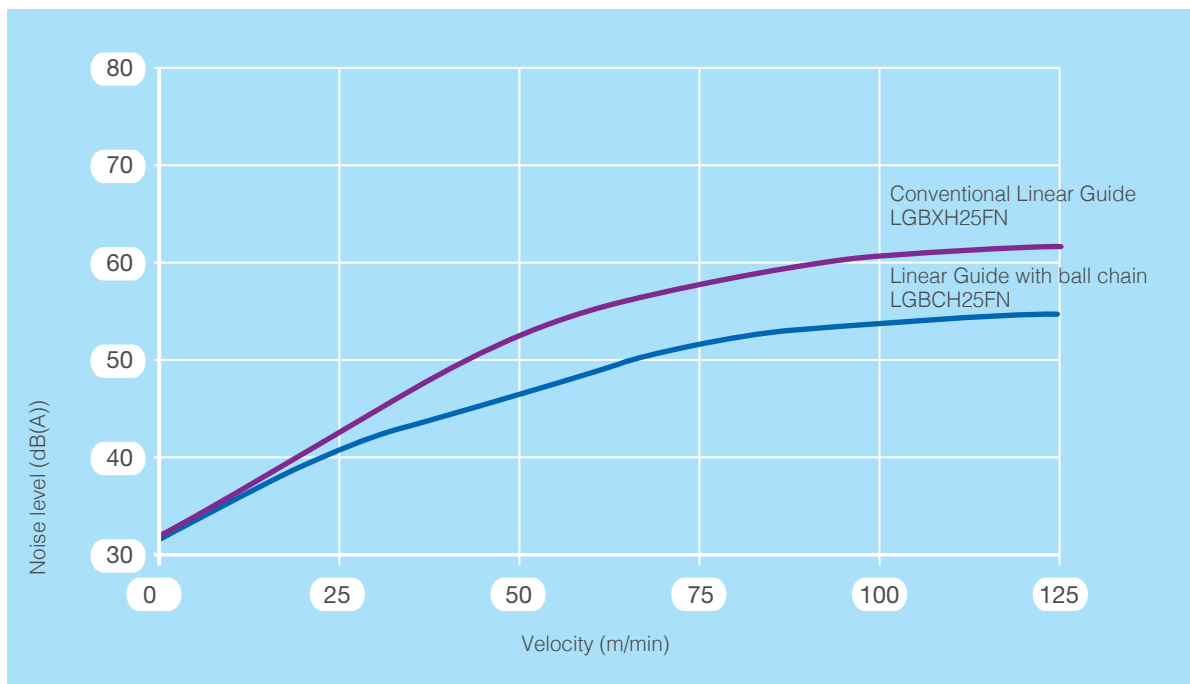

Figure 1.9 Noise generation of Linear Guide of Design Size 25

The chain in Linear Guide with ball chain has the function of a cage. It holds the balls at a constant distance from each other and controls their circulation. The structure of the carriages makes it impossible to implement a closed ball chain circulation. At the end of the ball chains, a space of about 1 ball diameter remains. The design of the ends of the SNR ball chain and the use of a spacer ball compensate for this space (Figure 1.10).

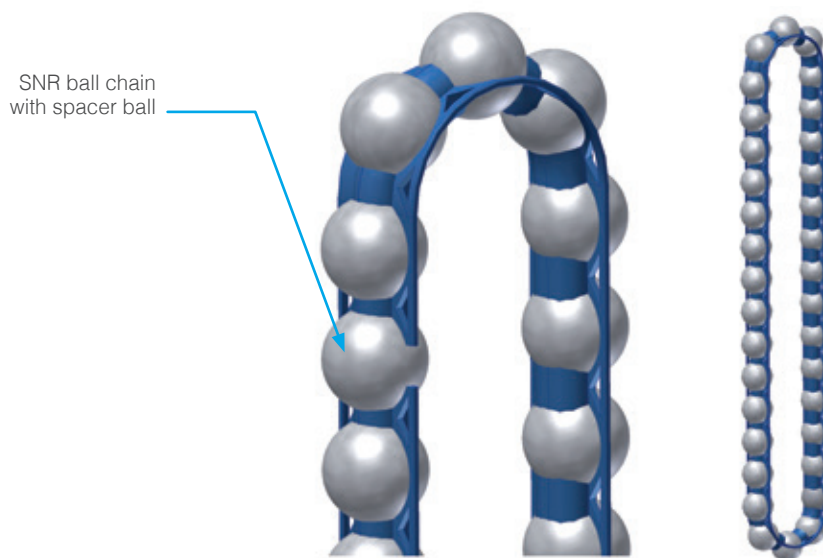

Figure 1.10 SNR ball chain

This design of the ball chain ends in connection with the spacer ball closes the circulation and makes the movement of the carriage smooth and quiet. (Figure 1.11).

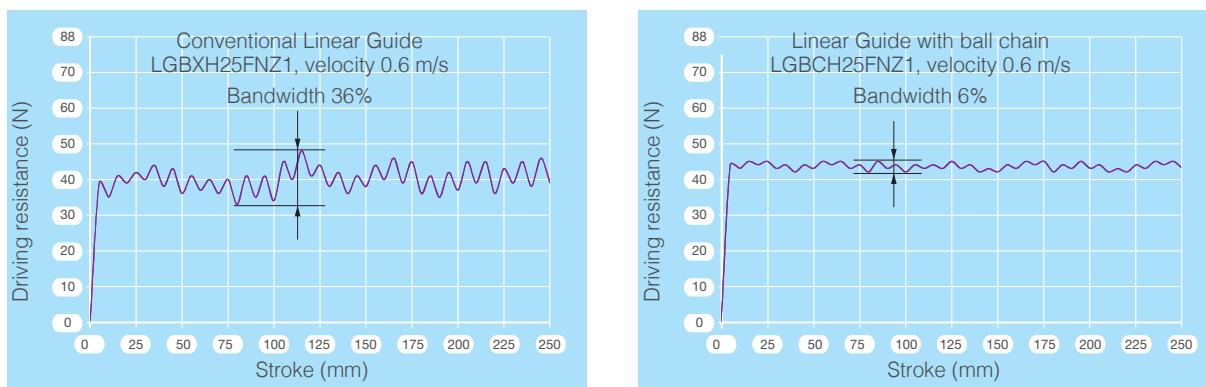

Figure 1.11 Driving resistance

1.3 Characteristics

Linear Guide have become more and more indispensable in the modern engineering.

The main features are:

- High dynamic
- Low friction
- High stiffness
- Optimal running performance
- Low wear
- Low-maintenance operation
- High efficiency
- Flexible sealing system

SNR Linear Guide consist of just a few modular designed components.

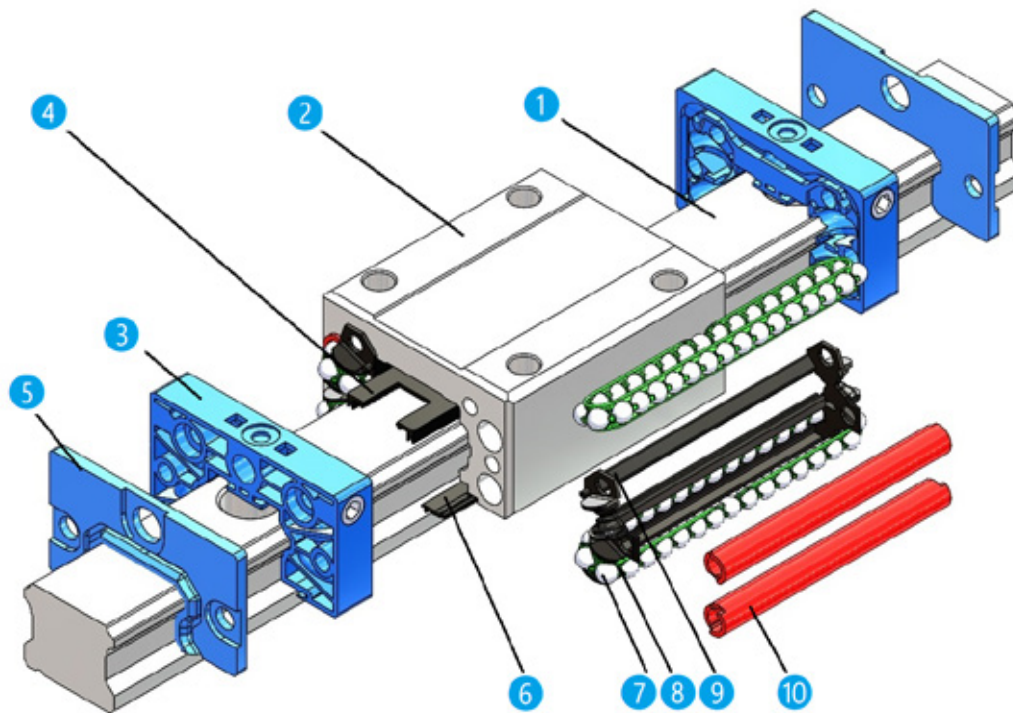
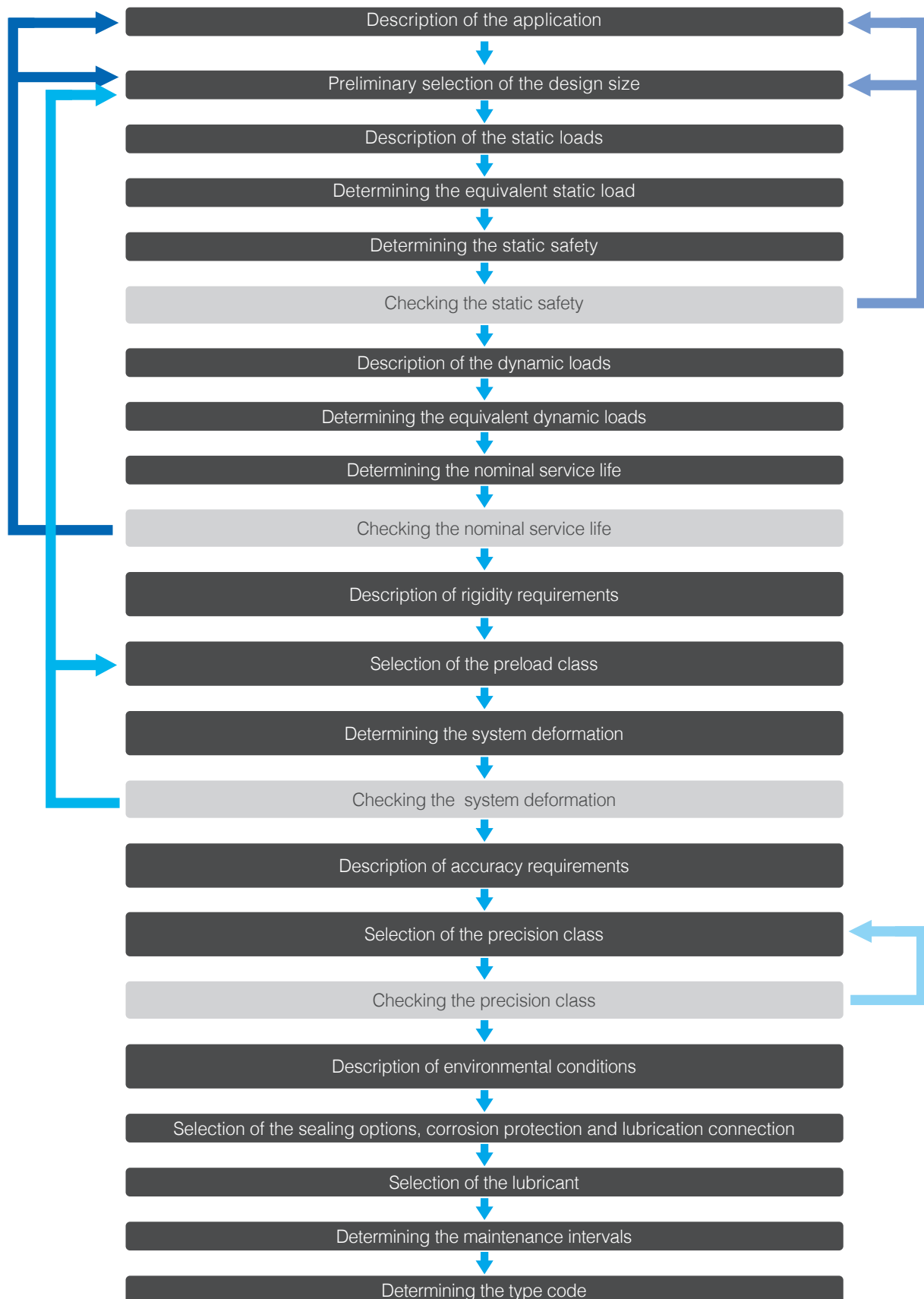

Figure 1.12 Structure

- | | |
|--------------|-------------------------|
| 1 Rail | 7 Balls |
| 2 Steel body | 8 Ball chain (optional) |
| 3 End plate | 9 Cage |
| 4 Inner seal | 10 Return tube |
| 5 End seal | |
| 6 Side seal | |

1.4 Selection criteria



2 System technology

2.1 Definitions

Service life time

The service life time L is the running distance that a component can handle before the first signs of material fatigue become apparent on the tracks or the rolling elements.

Nominal service life time L_{10}

The nominal service life time L_{10} is the calculated service life time of a single Linear Guide system or of a group of equivalent Linear Guide systems operating under equal conditions that can be reached with a probability of 90%, assuming the use of currently common materials of average manufacturing quality and common operating conditions.

Dynamic load rating C

The dynamic load rating C is the in size and direction constant, radial load that a linear roller bearing can theoretically withstand for a nominal service life of 5×10^4 m travelled distance (according to ISO 14728-1). When the calculation of the dynamic load rating is based on a nominal service life of 10^5 m, the dynamic load rating for a nominal service life of 5×10^4 m is divided by the conversion factor 1.26.

Static load rating C_0

The static load rating C_0 is the static, radial load that corresponds to the middle of the highest-stressed contact area between rolling element and race way of a calculated Hertz-type compression. The Hertz-type compression for the Linear Guide is, according to ISO 14728-1, between 4200 MPa and 4600 MPa and depends on the ball diameter and the osculation. This load leads to a permanent, total deformation of the rolling element that corresponds to a 0.0001 part of the rolling element diameter (according to ISO 14728-1).

2.2 Standards

DIN ISO 12090-1 Rolling bearings – Profiled rail guides for linear motion rolling bearings – Part 1: Boundary dimensions and tolerances for series 1, 2 and 3

DIN ISO 12090-2 Rolling bearings – Profiled rail guides for linear motion rolling bearings – Part 2: Boundary dimensions and tolerances for series 4 and 5

DIN ISO 14728-1 Roller bearings – Linear roller bearings – Part 1: Dynamic load ratings and nominal service life

DIN ISO 14728-2 Roller bearings – Linear roller bearings – Part 2: Static load ratings

DIN 637 Rolling bearings - Safety regulations for dimensioning and operation of profiled rail guides with recirculating rolling elements

The SNR Linear Guides comply with the RoHS Directive (EU Directive RoHS 2011/65/EU and 2015/863/EU and the Regulation (EG) No. 1907/2006 (REACH)). – SNR Linear Guides are not listed in the REGULATION (EU) 2023/1230 and are therefore not affected by this regulation.

2.3 Intended use

Linear Guides are assemblies. SNR Linear Guides may only be used within the limits of the type-specific load data in the product catalogue or supplementary technical calculations by us for linear movements.

Linear Guides may only be operated and serviced by persons who are familiar with them and have been informed about the dangers. This also means that this documentation has been completely read and taken note of.

Furthermore, an operating temperature between -10°C and +75°C must be adhered to.

Any other or additional use is considered improper. The manufacturer is not liable for any resulting damage. The user bears the risk alone.

2.4 Safety instructions

The following safety instructions must be observed when using Linear Guides:

- Use Linear Guides only in accordance with the intended use.
- Linear Guides may only be used within the limits of the technical parameters permitted in the product catalogue.
- Only products in a technically perfect condition may be used.
- In principle, changes to Linear Guides are not permitted.
- Do not reach into moving parts.
- Linear Guides must not be driven to the end stops.
- Use in safety-relevant applications is only permitted if such use is expressly specified in the product catalogue or has been confirmed by us.
- Linear Guides may only be used under the environmental conditions described in the product catalogue.
- Linear Guides may only be put into operation when it has been established that the assembly or the end product into which the Linear Guides have been installed complies with the country-specific regulations, safety regulations and standards of the application.
- Only accessories and spare parts approved by the manufacturer may be used.
- Do not stand under suspended loads. The individual components of Linear Guides are designed for the service life time of the Linear Guides. In exceptional cases, defects can occur and, if the Ball Screws are installed in a vertical position, the installed components can fall. Appropriate protective measures in accordance with EN ISO 13849-1 must be taken against this.
- The applicable regulations for accident prevention and environmental protection must be observed.
- Appropriate protective equipment must be worn when assembling and working on Linear Guides.
- Suitable and tested load handling devices that are adapted to the weight are to be used for lifting and transport.
- After all work on the machine, the safety devices must be re-assembled according to regulations and their function checked.
- Before start-up, ensure that all safety devices required for the application are available, properly installed and fully functional.
- Possible danger areas are to be clearly marked.

2.5 Coordinate system

The Linear Guides can be stressed by forces or moments. The coordinate system (Figure 2.1) shows the forces acting in the main load directions, the torques as well as the six degrees of freedom.

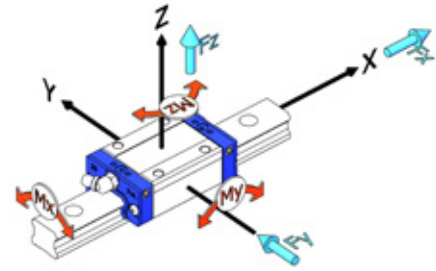

Figure 2.1 Coordinate system

Forces in the main load directions:

- F_X Movement force (X-direction)
- F_Y Tangential load (Y-direction)
- F_Z Radial load (Z-direction)

Moments:

- M_X Moment in roll direction (rotation around the X-axis)
- M_Y Moment in pitch direction (rotation around the Y-axis)
- M_Z Moment in yaw direction (rotation around the Z-axis)

Only five degrees of freedom are relevant for the Linear Guides. The X-direction is the movement direction of the guide. This defines the following accuracy values:

- Lateral movement (Y-direction)
- Height movement (Z-direction)
- Rolling (rotation around the X-axis)
- Pitching (rotation around the Y-axis)
- Yawing (rotation around the Z-axis)

2.6 Static safety

The design of Linear Guides must consider unexpected and unforeseeable forces and/or torques that are caused by vibration or shocks or short start/stop cycles (short strokes) during operation or standstill as well as overhanging loads. A safety factor is particularly important in such cases. The static safety factor f_s is intended to prevent unacceptable, permanent deformation of the tracks and the rolling elements. It is the ratio of the static load rating C_0 to the maximum occurring force F_{0max} . The highest amplitude is relevant, even when it occurs only for a very short time.

$$f_s = \frac{C_0}{F_{0max}} * f_H * f_T * f_C \quad [2.1]$$

- f_s static safety factor / static safety
- C_0 static load rating [N]
- F_{0max} maximum static load [N]
- f_H Hardness factor
- f_T Temperature factor
- f_C Contact factor

The static safety factor should be bigger than 2 for normal operating conditions. The recommended values listed in Table 2.1, should be used for the factor f_s under special operating conditions.

We recommend that you contact our application engineers when the loads are partially unknown or difficult to estimate.

Table 2.1 Values of the static safety factor

Operating conditions	Static safety factor f_s
slow movement low loads no vibration and shocks	1,0...1,3
slow movement low loads light vibration and shocks	1,2...1,7
slow movement medium loads vibration and shocks	1,5...2,5
fast movement high loads vibration and shocks	2,0...4,0
fast movement high loads strong vibration and shocks	3,0...8,0

2.7 Service life time calculation

The nominal service life time of a Linear Guide is calculated with the following equation:

Ball guides

$$L_{10} = \left(\frac{C}{F} * \frac{f_H * f_T * f_C}{f_W} \right)^3 * 5 * 10^4 \quad [2.2]$$

Roller guides

$$L_{10} = \left(\frac{C}{F} * \frac{f_H * f_T * f_C}{f_W} \right)^{\frac{10}{3}} * 10^5 \quad [2.3]$$

L_{10}	Nominal service life time [m]
C	Dynamic load rating [N]
F	Dynamic load [N]
f_H	Hardness factor
f_T	Temperature factor
f_C	Contact factor
f_W	Load factor

The service life time in operating hours can be determined when the stroke length and the stroke frequency remain constant during the service life time.

$$L_h = \frac{L_{10}}{2 \cdot S \cdot n \cdot 60} \quad [2.4]$$

L_{10}	Nominal service life time [m]
L_h	Service live in hours [h]
S	Stroke length [m]
n	Stroke frequency (double-strokes per minute) [min^{-1}]

It is very difficult to determine the active load for the service life time calculation. The Linear Guide systems are usually exposed to oscillations or vibrations resulting from the process or drive forces. Shocks can damage machine elements when the load peaks are higher than the maximum additional load.

This applies to the dynamic as well as the static state of the total system. The service life time also depends on parameters such as the surface hardness of the rolling elements, the race ways and the temperature of the system. The modified service life time calculation takes the abovementioned conditions into consideration.

2.7.1 Influence factors

Hardness factor f_H

The hardness of the rolling elements and the raceways must be between 58 HRC and 60 HRC. This value ensures optimal running properties and the best possible functional properties of the Linear Guide.

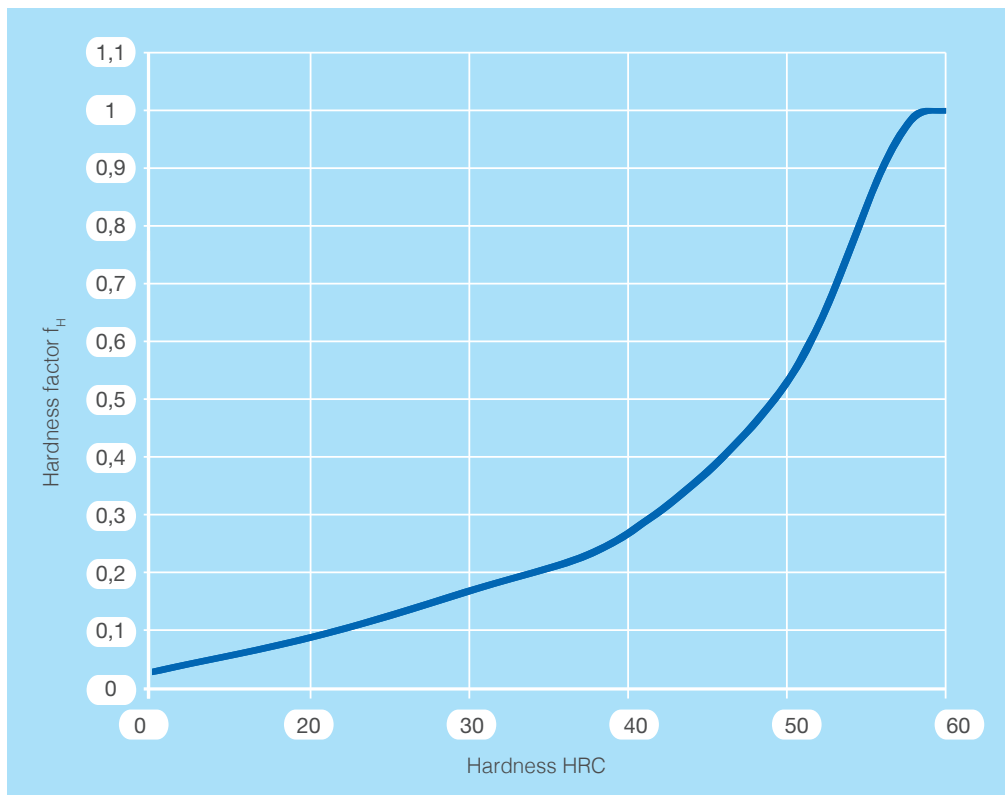

Figure 2.2 Hardness factor f_H

The SNR Linear Guides comply with the above mentioned conditions. Therefore, the hardness factor does not need to be considered ($f_H=1$). The hardness corrections (Figure 2.2) are only required when a special version made of special material with a hardness below 58 HRC is used.

Temperature factor f_T

Corrections to the service life time calculations (Figure 2.3) must be made when the environmental temperature of the Linear Guide exceeds 100°C during operation.

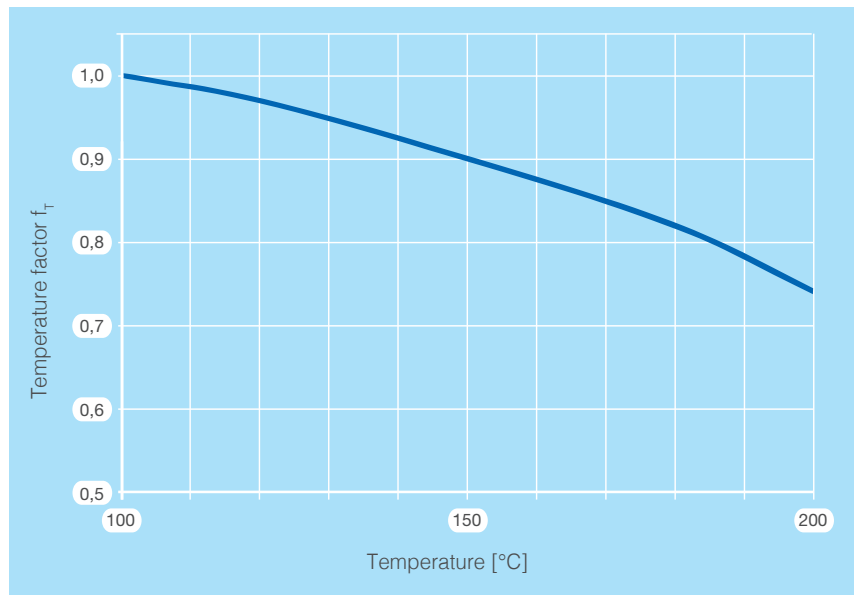

Figure 2.3 Temperature factor f_T

The standard version of the SNR Linear Guides can be used up to a maximum temperature of 80°C.

Contact factor f_c

When two or more carriages are installed very close to each other, the movement is affected by torques, installation accuracy and other factors, so that an even load distribution is hard to achieve. Under such conditions, an appropriate contact factor (Table 2.2) must be taken into account.

Table 2.2 Contact factor

Number of closely spaced carriages	f_c
1	1,00
2	0,81
3	0,72
4	0,66
5	0,61

Load factor f_w

Vibrations and shocks that may occur during operation, for example as a result of high speeds, repeated starting and stopping, process forces or sudden loads, can have a significant effect on the total calculation. It is in some cases very difficult to determine their effects. Empirically determined load factors (Table 2.3) must be used when the actual loads on the Linear Guide cannot be measured or can be significantly higher than calculated.

Table 2.3 Load factor

Operating conditions	Velocity [m/s]	Load factor f_w
no or very low vibration and shocks	$\leq 0,25$	1,0...1,2
low vibration and shocks	$0,25 \dots \leq 1,0$	1,2...1,5
medium vibration and shocks	$1,0 \dots \leq 2,0$	1,5...2,0
strong vibration and shocks	$> 2,0$	2,0...3,5
Short stroke application		3,5...5,0

2.7.2 Acting load - equivalence factors

One-rail application

For tight installation conditions, often only one or several Linear Guides with one carriage or one Linear Guide with several carriages is used. The service life time of the Linear Guide can be shortened in such cases, due to the increased wear at the carriage ends. Under such operating conditions, the torques must be multiplied by appropriate equivalence factors (Table 2.4 to Table 2.6).

The equivalent load is determined as follows:

$$F_E = k \cdot M \quad [2.7]$$

- F_E Equivalent load per guide [N]
 k Equivalence factors (Table 2.4 to Table 2.6)
 M corresponds to the active moment [Nm]

Table 2.4 Equivalence factors Standard Linear Guides

Type	Equivalence factor [m ⁻¹]				
	k1x	k1y	k2y	k1z	k2z
LGB_15 BS/FS	143,5	309,4	38,1	309,4	38,1
LGB_15 BN/FN	145,3	165,8	28,8	165,8	28,8
LGB_15 BL/FL	144,9	140,6	26,0	140,6	26,0
LGB_20 BS/FS	107,6	241,4	32,5	241,4	32,5
LGB_20 BN/FN	107,1	138,2	24,5	138,2	24,5
LGB_20 BL/FL	106,7	109,6	21,3	109,6	21,3
LGB_20 BE/FE	106,9	87,8	18,4	87,8	18,4
LGB_25 BS/FS	92,8	207,2	29,2	207,2	29,2
LGB_25 BN/FN	93,4	116,6	21,6	116,6	21,6
LGB_25 BL/FL	93,1	92,9	18,7	92,9	18,7
LGB_25 BE/FE	93,1	77,2	16,5	77,2	16,5
LGB_30 FS	77,3	179,8	24,6	179,8	24,6
LGB_30 BN/FN	77,2	99,1	18,1	99,1	18,1
LGB_30 BL/FL	77,2	86,0	16,6	86,0	16,6
LGB_30 BE/FE	77,2	64,8	13,7	64,8	13,7
LGB_35 FS	63,3	150,7	21,1	150,7	21,1
LGB_35 BN/FN	63,2	83,4	15,4	83,4	15,4
LGB_35 BL/FL	63,3	72,5	14,2	72,5	14,2
LGB_35 BE/FE	63,2	54,8	11,7	54,8	11,7
LGB_45 BN/FN	47,3	71,4	13,4	71,4	13,4
LGB_45 BL/FL	47,3	61,0	12,1	61,0	12,1
LGB_45 BE/FE	47,3	48,3	10,3	48,3	10,3
LGB_55 BN/FN	40,4	57,9	11,3	57,9	11,3
LGB_55 BL/FL	40,4	43,6	9,3	43,6	9,3
LGB_55 BE/FE	40,4	39,2	8,6	39,2	8,6

- k1x Equivalence factor for 1 carriage in Mx-direction
k1y Equivalence factor for 1 carriage in My-direction
k2y Equivalence factor for 2 carriages with direct contact in My-direction
k1z Equivalence factor for 1 carriage in Mz-direction
k2z Equivalence factor for 2 carriages with direct contact in Mz-direction

Table 2.5 Equivalence factors wide Standard Linear Guides

Type	Equivalence factor [m ¹]				
	k1x	k1y	k2y	k1z	k2z
LGBXH21 TN/WN	50,9	146,3	28,6	146,3	28,6
LGBXH27 TN/WN	48,8	120,6	23,5	120,6	23,5
LGBXH35 TN/WN	30,5	74,6	16,2	74,6	16,2

- k1x Equivalence factor for 1 carriage in Mx-direction
- k1y Equivalence factor for 1 carriage in My-direction
- k2y Equivalence factor for 2 carriages with direct contact in My-direction
- k1z Equivalence factor for 1 carriage in Mz-direction
- k2z Equivalence factor for 2 carriages with direct contact in Mz-direction

Table 2.6 Equivalence factors Miniature guides

Type	Equivalence factor [m ¹]				
	k1x	k1y	k2y	k1z	k2z
LGM_07 BN	300,8	488,7	64,2	488,7	53,0
LGM_09 BN	209,1	255,6	53,0	255,6	53,0
LGM_09 BL	220,7	194,7	42,5	194,7	42,5
LGM_12 BN	152,2	291,7	47,0	291,7	47,0
LGM_12 BL	154,7	187,9	36,4	187,9	36,4
LGM_15 BN	142,8	219,6	38,2	219,6	38,2
LGM_15 BL	143,2	145,8	28,8	145,8	28,8
LGM_09 WN	106,8	236,4	43,2	236,4	43,2
LGM_09 WL	105,1	153,9	34,5	153,9	34,5
LGM_12 WN	80,5	204,2	37,9	204,2	37,9
LGM_12 WL	80,2	144,1	29,8	144,1	29,8
LGM_15 WN	48,9	167,8	30,5	167,8	30,5
LGM_15 WL	48,0	110,3	23,7	110,3	23,7

- k1x Equivalence factor for 1 carriage in Mx-direction
- k1y Equivalence factor for 1 carriage in My-direction
- k2y Equivalence factor for 2 carriages with direct contact in My-direction
- k1z Equivalence factor for 1 carriage in Mz-direction
- k2z Equivalence factor for 2 carriages with direct contact in Mz-direction

Two-rail application

The following requirements and operating conditions (Figure 2.4) must be defined for calculating the service life time:

- Stroke length s [mm]
- Velocity diagram (Figure 2.5)
- Velocity v [m/s]
- Acceleration/deceleration a [m/s²]
- Movement cycles, number of double-strokes per minute n [min⁻¹]
- Arrangement of the Linear Guide (number of rails and carriages) l_0, l_1 , [mm]
- Installation position (horizontal, vertical, diagonal, wall installation, tilted by 180°)
- Mass m [kg]
- Direction of the outer forces
- Positions of the centres of gravity l_2, l_3, l_4 , [mm]
- Position of the drive l_5, l_6 , [mm]
- Required service life L [km] or [h]

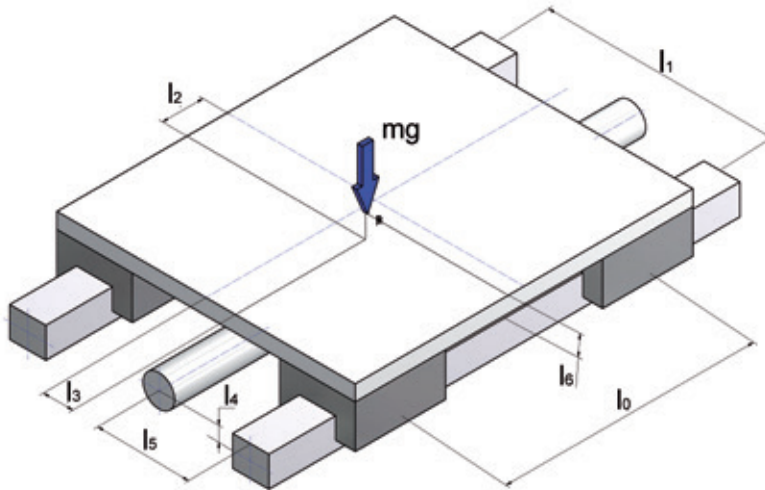

Figure 2.4 Definition of the conditions

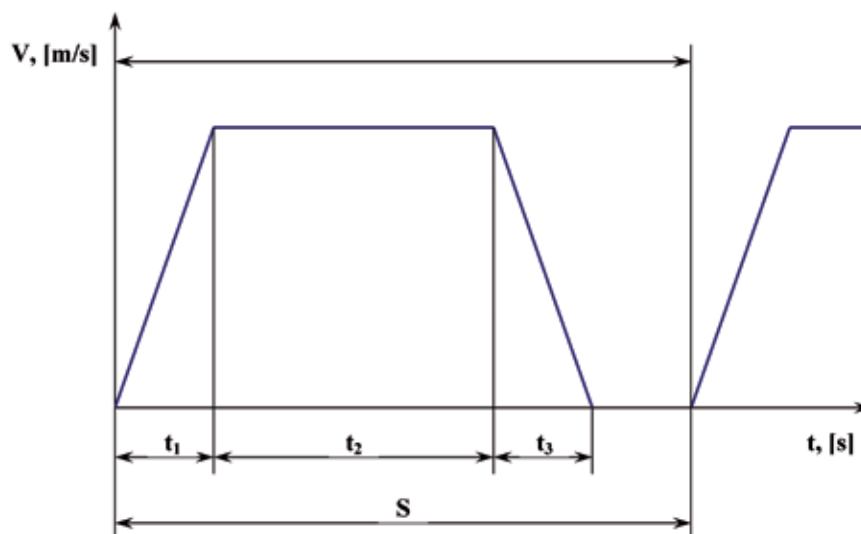

Figure 2.5 Velocity/time diagram

2.7.3 Equivalent loads

The (radial and tangential) loads as well as torque loads may act on the Linear Guide from different directions at the same time (Figure 2.6). In this case, the service life is calculated by using the equivalent load, which includes the radial, tangential and other loads.

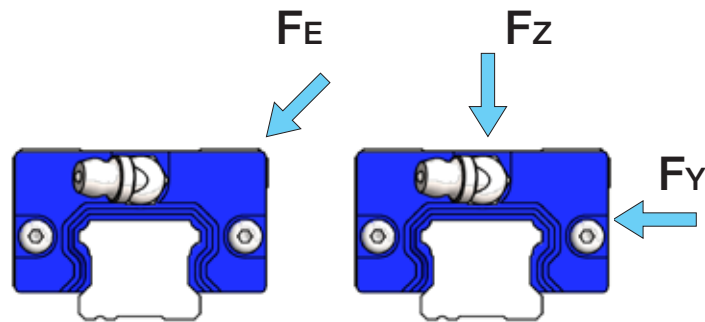

Figure 2.6 Equivalent load F_E

$$F_E = |F_Y| + |F_Z| \quad [2.8]$$

F_E - Equivalent load [N]

F_Y - Tangential load [N]

F_Z - Radial load [N]

The calculation of the equivalent load F_E considers that the SNR Linear Guides have the same loadrating capacity in all main directions.

Dynamic equivalent load

It is common that different, varying process forces affect the total system during operation. The guides are, for example, exposed to changing loads during upward and downward movements for picking and placing applications. Where such varying loads occur, they must be considered in the service life time calculations. The calculation of the dynamically equivalent load determines the load on a carriage for each individual movement phase n_1, n_2, \dots, n_n (see Chapter 2.7.2) and is summarised in a resulting load for the total cycle. The load change can take place in various ways:

- Stepwise (Figure 2.7)
- Linear (Figure 2.8)
- Sinusoidal (Figure 2.9 and 2.10)

Stepwise load change

$$F_m = \sqrt[3]{\frac{1}{S} (F_1^3 \cdot S_1 + F_2^3 \cdot S_2 + \dots + F_n^3 \cdot S_n)} \quad [2.9]$$

- F_m Dynamic equivalent load [N]
- F_n Load change [N]
- S Total travel [mm]
- S_n Travel during load change F_n [mm]

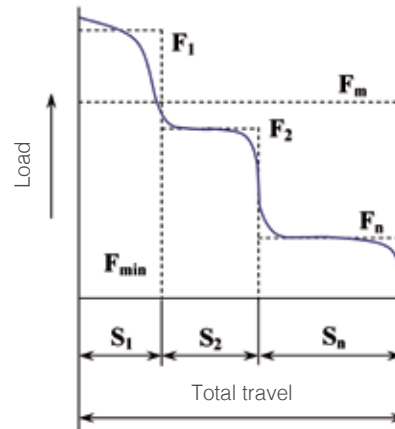

Figure 2.7 Stepwise load change

Linear load change

$$F_m \cong \frac{1}{3} (F_{MIN} + 2 \cdot F_{MAX}) \quad [2.10]$$

- F_{MIN} Minimum load [N]
- F_{MAX} Maximum load [N]

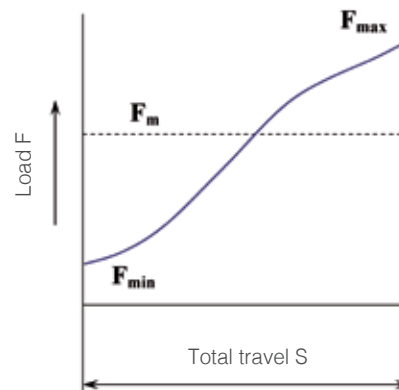

Figure 2.8 Linear load change

Sinusoidal load change

$$F_m \cong 0,65 * F_{MAX} \quad [2.11]$$

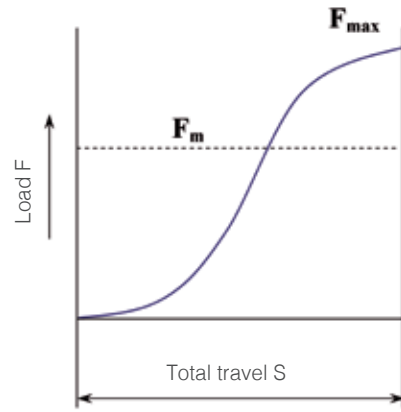

Figure 2.9 Sinusoidal load change (a)

Sinusoidal load change

[2.12]

$$F_m \cong 0,75 * F_{MAX}$$

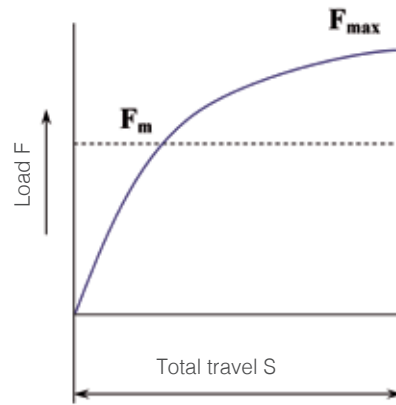

Figure 2.10 Sinusoidal load change (b)

2.7.4 Calculation examples

Example 1

Horizontal installation position with overhanging load

One carriage

LGBCH20FN

Gravity constant $g=9.8 \text{ m/s}^2$

Mass $m=10 \text{ kg}$

$l_2=200 \text{ mm}$, $l_3=100 \text{ mm}$

$C=17,71 \text{ kN}$

$C_0=30,50 \text{ kN}$

Normal operating conditions without vibrations $f_w = 1,5$

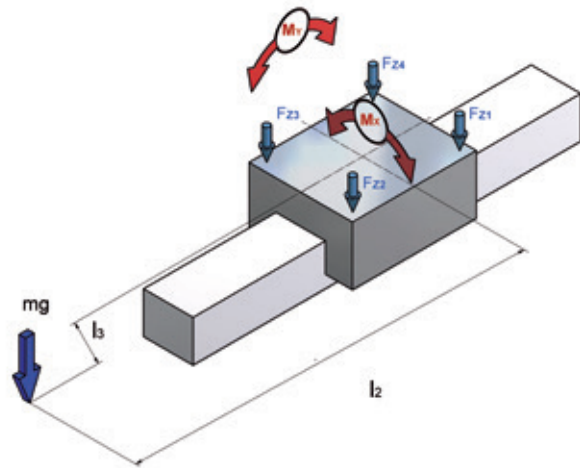

Figure 2.11 Calculation example 1

Calculation:

The equivalent load for the Linear Guide is calculated, taking the formula [2.7] and the equivalence factors (Table 2.5) into account.

$$Fz_1 = mg - k_x * mg * l_3 - k_y * mg * l_2 = 10 * 9,8 - 107 * 10 * 9,8 * 0,1 - 138 * 10 * 9,8 * 0,2 = -3.655,4 \text{ N}$$

$$Fz_2 = mg - k_x * mg * l_3 + k_y * mg * l_2 = 10 * 9,8 - 107 * 10 * 9,8 * 0,1 + 138 * 10 * 9,8 * 0,2 = 1.754,2 \text{ N}$$

$$Fz_3 = mg + k_x * mg * l_3 + k_y * mg * l_2 = 10 * 9,8 + 107 * 10 * 9,8 * 0,1 + 138 * 10 * 9,8 * 0,2 = 3.851,4 \text{ N}$$

$$Fz_4 = mg + k_x * mg * l_3 - k_y * mg * l_2 = 10 * 9,8 + 107 * 10 * 9,8 * 0,1 - 138 * 10 * 9,8 * 0,2 = -1.558,2 \text{ N}$$

The static safety factor for the maximum load of 3.851,4 N is calculated according to [2.1].

$$f_s = \frac{C_0}{F_{0MAX}} = \frac{30.500}{3.851,4} = 7,9$$

The nominal service life time for the maximum load 3.851,4 N is calculated according to [Chapter 2.7].

$$L_{10} = \left(\frac{C}{F} * \frac{f_H * f_T * f_C}{f_w} \right)^3 * 5 * 10^4 = \left(\frac{17.710}{3.851,4} * \frac{1}{1,5} \right)^3 * 5 * 10^4 = 1.440.443 \text{ m} = 14.440 \text{ km}$$

Example 2

Horizontal installation position with overhanging load and 2 rails arranged in parallel. Two carriages per rail, arrangement with mobile table

LGBCH30FN

Gravity constant $g=9.8 \text{ m/s}^2$

Mass $m=400 \text{ kg}$

$l_0=600 \text{ mm}$, $l_1=450 \text{ mm}$, $l_2=400 \text{ mm}$, $l_3=350 \text{ mm}$

$C=36,71 \text{ kN}$

$C_0=54,570 \text{ kN}$

Normal operating conditions without vibrations

$f_w=1,5$

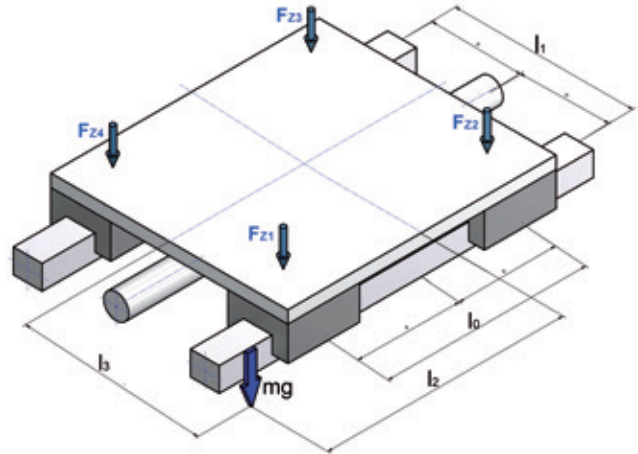

Figure 2.12 Calculation example 2

Calculation:

a) The active radial load per carriage at constant velocity is calculated as follows:

$$F_{Z1} = \frac{mg}{4} + \frac{mg \cdot l_2}{2 \cdot l_0} + \frac{mg \cdot l_3}{2 \cdot l_1} = \frac{400 \cdot 9,8}{4} + \frac{400 \cdot 9,8 \cdot 400}{2 \cdot 600} + \frac{400 \cdot 9,8 \cdot 350}{2 \cdot 450} = 3.811,11 \text{ N}$$

$$F_{Z2} = \frac{mg}{4} - \frac{mg \cdot l_2}{2 \cdot l_0} + \frac{mg \cdot l_3}{2 \cdot l_1} = \frac{400 \cdot 9,8}{4} - \frac{400 \cdot 9,8 \cdot 400}{2 \cdot 600} + \frac{400 \cdot 9,8 \cdot 350}{2 \cdot 450} = 1.197,77 \text{ N}$$

$$F_{Z3} = \frac{mg}{4} - \frac{mg \cdot l_2}{2 \cdot l_0} - \frac{mg \cdot l_3}{2 \cdot l_1} = \frac{400 \cdot 9,8}{4} - \frac{400 \cdot 9,8 \cdot 400}{2 \cdot 600} - \frac{400 \cdot 9,8 \cdot 350}{2 \cdot 450} = -1.851,11 \text{ N}$$

$$F_{Z4} = \frac{mg}{4} + \frac{mg \cdot l_2}{2 \cdot l_0} - \frac{mg \cdot l_3}{2 \cdot l_1} = \frac{400 \cdot 9,8}{4} + \frac{400 \cdot 9,8 \cdot 400}{2 \cdot 600} - \frac{400 \cdot 9,8 \cdot 350}{2 \cdot 450} = 762,23 \text{ N}$$

b) The statistical safety factor is calculated for carriage 1 according to [2.1] for a maximum load of 3,811.11 N.

$$f_s = \frac{C_0}{F_{0MAX}} = \frac{54.570}{3.811,11} = 14,3$$

c) The service life time of the four runner blocks is calculated according to [2.5]

$$L_1 = \left(\frac{C}{F_{Z1}} * \frac{f_H * f_T * f_C}{f_w} \right)^3 * 5 * 10^4 = \left(\frac{36.710}{3.811,11} * \frac{1}{1,5} \right)^3 * 5 * 10^4 = 13.240.211 \text{ m} = 13.240 \text{ km}$$

$$L_2 = \left(\frac{C}{F_{Z2}} * \frac{f_H * f_T * f_C}{f_w} \right)^3 * 5 * 10^4 = \left(\frac{36.710}{1.197,77} * \frac{1}{1,5} \right)^3 * 5 * 10^4 = 426.509.871 \text{ m} = 426.510 \text{ km}$$

$$L_3 = \left(\frac{C}{F_{Z3}} * \frac{f_H * f_T * f_C}{f_w} \right)^3 * 5 * 10^4 = \left(\frac{36.710}{1.851,11} * \frac{1}{1,5} \right)^3 * 5 * 10^4 = 115.545.411 \text{ m} = 115.545 \text{ km}$$

$$L_4 = \left(\frac{C}{F_{Z4}} * \frac{f_H * f_T * f_C}{f_w} \right)^3 * 5 * 10^4 = \left(\frac{36.710}{762,23} * \frac{1}{1,5} \right)^3 * 5 * 10^4 = 1.654.974.350 \text{ m} = 1.654.974 \text{ km}$$

Example 3

Vertical installation position (e.g. transport lift, Z-axis of a lifting device) with inertia forces, 2 rails arranged in parallel,

2 carriages per rail,

LGBCH20FN

$v=1$ m/s

$a=0,5$ m/s²

$s_1=1000$ mm

$s_2=2000$ mm

$s_3=1000$ mm

Mass $m=100$ kg

Gravity constant $g=9.8$ m/s²

$l_0=300$ mm, $l_1=500$ mm, $l_5=250$ mm, $l_6=280$ mm

$C=17,71$ kN

$C_0=30,50$ kN

$f_w=2,0$ (T able 2.3)

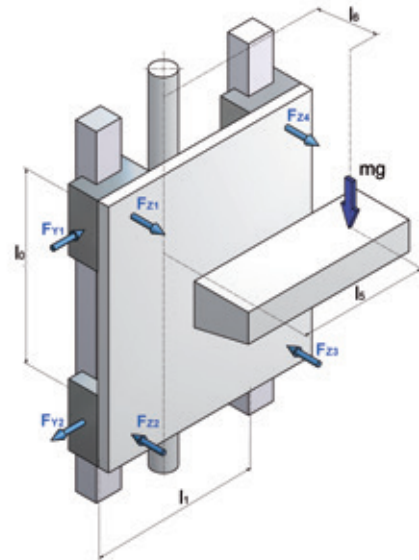

Figure 2.13 Calculation example 3

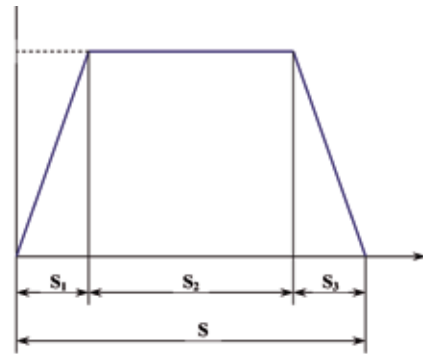

Figure 2.14 Velocity/distance diagram

Calculation:

a) The active loads are calculated per carriage

During the acceleration phase

Radial loads

$$F_{BeschZ1} = \frac{m(g+a) \cdot l_6}{2 \cdot l_0} = \frac{100 \cdot (9,8 + 0,5) \cdot 280}{2 \cdot 300} = 480,67 \text{ N}$$

$$F_{BeschZ2} = -\frac{m(g+a) \cdot l_6}{2 \cdot l_0} = -\frac{100 \cdot (9,8 + 0,5) \cdot 280}{2 \cdot 300} = -480,67 \text{ N}$$

$$F_{BeschZ3} = -\frac{m(g+a) \cdot l_6}{2 \cdot l_0} = -\frac{100 \cdot (9,8 + 0,5) \cdot 280}{2 \cdot 300} = -480,67 \text{ N}$$

$$F_{BeschZ4} = \frac{m(g+a) \cdot l_6}{2 \cdot l_0} = \frac{100 \cdot (9,8 + 0,5) \cdot 280}{2 \cdot 300} = 480,67 \text{ N}$$

Tangential loads

$$F_{BeschY1} = \frac{m(g+a) * l_5}{2 * l_0} = \frac{100 * (9,8 + 0,5) * 250}{2 * 300} = 429,17 \text{ N}$$

$$F_{BeschY2} = -\frac{m(g+a) * l_5}{2 * l_0} = -\frac{100 * (9,8 + 0,5) * 250}{2 * 300} = -429,17 \text{ N}$$

$$F_{BeschY3} = -\frac{m(g+a) * l_5}{2 * l_0} = -\frac{100 * (9,8 + 0,5) * 250}{2 * 300} = -429,17 \text{ N}$$

$$F_{BeschY4} = \frac{m(g+a) * l_5}{2 * l_0} = \frac{100 * (9,8 + 0,5) * 250}{2 * 300} = 429,17 \text{ N}$$

At constant velocity

Radial loads

$$F_{KonstZ1} = \frac{mg * l_6}{2 * l_0} = \frac{100 * 9,8 * 280}{2 * 300} = 457,33 \text{ N}$$

$$F_{KonstZ2} = -\frac{mg * l_6}{2 * l_0} = -\frac{100 * 9,8 * 280}{2 * 300} = -457,33 \text{ N}$$

$$F_{KonstZ3} = -\frac{mg * l_6}{2 * l_0} = -\frac{100 * 9,8 * 280}{2 * 300} = -457,33 \text{ N}$$

$$F_{KonstZ4} = \frac{mg * l_6}{2 * l_0} = \frac{100 * 9,8 * 280}{2 * 300} = 457,33 \text{ N}$$

Tangential loads

$$F_{KonstY1} = \frac{mg * l_5}{2 * l_0} = \frac{100 * 9,8 * 250}{2 * 300} = 408,33 \text{ N}$$

$$F_{KonstY2} = -\frac{mg * l_5}{2 * l_0} = -\frac{100 * 9,8 * 250}{2 * 300} = -408,33 \text{ N}$$

$$F_{KonstY3} = -\frac{mg * l_5}{2 * l_0} = -\frac{100 * 9,8 * 250}{2 * 300} = -408,33 \text{ N}$$

$$F_{KonstY4} = \frac{mg * l_5}{2 * l_0} = \frac{100 * 9,8 * 250}{2 * 300} = 408,33 \text{ N}$$

During the deceleration phase

Radial loads

$$F_{VerzZ1} = \frac{m(g-a) * l_6}{2 * l_0} = \frac{100 * (9,8 - 0,5) * 280}{2 * 300} = 434 \text{ N}$$

$$F_{VerzZ2} = -\frac{m(g-a) * l_6}{2 * l_0} = -\frac{100 * (9,8 - 0,5) * 280}{2 * 300} = -434 \text{ N}$$

$$F_{VerzZ3} = -\frac{m(g-a) * l_6}{2 * l_0} = -\frac{100 * (9,8 - 0,5) * 280}{2 * 300} = -434 \text{ N}$$

$$F_{VerzZ4} = \frac{m(g-a) * l_6}{2 * l_0} = \frac{100 * (9,8 - 0,5) * 280}{2 * 300} = 434 \text{ N}$$

Tangential loads

$$F_{VerzY1} = \frac{m(g-a) * l_5}{2 * l_0} = \frac{100 * (9,8 - 0,5) * 250}{2 * 300} = 387,50 \text{ N}$$

$$F_{VerzY2} = -\frac{m(g-a) * l_5}{2 * l_0} = -\frac{100 * (9,8 - 0,5) * 250}{2 * 300} = -387,50 \text{ N}$$

$$F_{VerzY3} = -\frac{m(g-a) * l_5}{2 * l_0} = -\frac{100 * (9,8 - 0,5) * 250}{2 * 300} = -387,50 \text{ N}$$

$$F_{VerzY4} = \frac{m(g-a) * l_5}{2 * l_0} = \frac{100 * (9,8 - 0,5) * 250}{2 * 300} = 387,50 \text{ N}$$

b) The combined radial and tangential loads are calculated per carriage according to [2.8].

During the acceleration phase

$$F_{BeschE1} = |F_{BeschZ1}| + |F_{BeschY1}| = 909,84 \text{ N}$$

$$F_{BeschE2} = |F_{BeschZ2}| + |F_{BeschY2}| = 909,84 \text{ N}$$

$$F_{BeschE3} = |F_{BeschZ3}| + |F_{BeschY3}| = 909,84 \text{ N}$$

$$F_{BeschE4} = |F_{BeschZ4}| + |F_{BeschY4}| = 909,84 \text{ N}$$

At constant velocity

$$F_{KonstE1} = |F_{KonstZ1}| + |F_{KonstY1}| = 865,67 \text{ N}$$

$$F_{KonstE2} = |F_{KonstZ2}| + |F_{KonstY2}| = 865,67 \text{ N}$$

$$F_{KonstE3} = |F_{KonstZ3}| + |F_{KonstY3}| = 865,67 \text{ N}$$

$$F_{KonstE4} = |F_{KonstZ4}| + |F_{KonstY4}| = 865,67 \text{ N}$$

During the deceleration phase

$$F_{VerzE1} = |F_{VerzZ1}| + |F_{VerzY1}| = 821,50 \text{ N}$$

$$F_{VerzE2} = |F_{VerzZ2}| + |F_{VerzY2}| = 821,50 \text{ N}$$

$$F_{VerzE3} = |F_{VerzZ3}| + |F_{VerzY3}| = 821,50 \text{ N}$$

$$F_{VerzE4} = |F_{VerzZ4}| + |F_{VerzY4}| = 821,50 \text{ N}$$

c) The static safety factor for the maximum load on the Linear Guide during the acceleration phase is calculated according to [2.1].

$$f_s = \frac{C_0}{F_{0MAX}} = \frac{30.500}{909,84} = 33,5$$

d) The active, dynamic, equivalent load is calculated according to [2.9]

$$S = S_1 + S_2 + S_3 = 4.000 \text{ mm}$$

$$F_{m1} = \sqrt[3]{\frac{1}{S} (F_{BeschE1}^3 * S_1 + F_{KonstE1}^3 * S_2 + F_{VerzE1}^3 * S_3)} =$$

$$= \sqrt[3]{\frac{1}{4.000} * (909,84^3 * 1.000 + 865,67^3 * 2.000 + 821,50^3 * 1.000)} = 866,79 \text{ N}$$

$$F_{m2} = \sqrt[3]{\frac{1}{S} (F_{BeschE2}^3 * S_1 + F_{KonstE2}^3 * S_2 + F_{VerzE2}^3 * S_3)} =$$

$$= \sqrt[3]{\frac{1}{4.000} * (909,84^3 * 1.000 + 865,67^3 * 2.000 + 821,50^3 * 1.000)} = 866,79 \text{ N}$$

$$F_{m3} = \sqrt[3]{\frac{1}{S} (F_{BeschE3}^3 * S_1 + F_{KonstE3}^3 * S_2 + F_{VerzE3}^3 * S_3)} =$$

$$= \sqrt[3]{\frac{1}{4.000} * (909,84^3 * 1.000 + 865,67^3 * 2.000 + 821,50^3 * 1.000)} = 866,79 \text{ N}$$

$$F_{m4} = \sqrt[3]{\frac{1}{S} (F_{BeschE4}^3 * S_1 + F_{KonstE4}^3 * S_2 + F_{VerzE4}^3 * S_3)} =$$

$$= \sqrt[3]{\frac{1}{4.000} * (909,84^3 * 1.000 + 865,67^3 * 2.000 + 821,50^3 * 1.000)} = 866,79 \text{ N}$$

e) The nominal service life time is calculated according to [2.5].

$$L_1 = \left(\frac{C}{F_{m1}} * \frac{f_H * f_T * f_C}{f_w} \right)^3 * 5 * 10^4 = \left(\frac{17.710}{866,79} * \frac{1}{2,0} \right)^3 * 5 * 10^4 = 53.515.380 \text{ m} = 53.515 \text{ km}$$

Example 4

Horizontal installation position (e.g. transport frame)
with inertial forces, 2 rails arranged in parallel,
2 carriages per rail,

LGBCH25FN

$v=1 \text{ m/s}$

$t_1=1 \text{ s}$

$t_2=2 \text{ s}$

$t_3=1 \text{ s}$

$s=4\,000 \text{ mm}$

Mass $m=150 \text{ kg}$

Gravity constant $=9,8 \text{ m/s}^2$

$l_0=600 \text{ mm}$, $l_1=400 \text{ mm}$, $l_5=150 \text{ mm}$, $l_6=500 \text{ mm}$

$C=24,85 \text{ kN}$

$C_0=47,07 \text{ kN}$

$f_w=2,0$ (according Table 2.3)

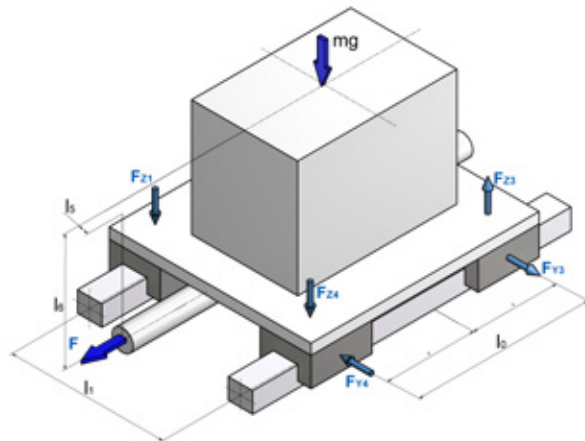

Figure 2.15 Calculation example 4

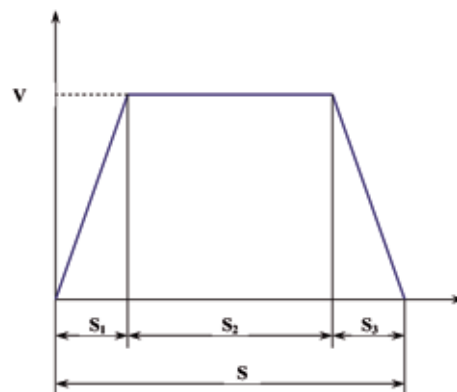

Figure 2.16 Velocity/distance diagram

Calculation:

a) Distance and acceleration calculation

$$\text{Acceleration phase: } a_1 = \frac{V}{t_1} = \frac{1}{1} = 1 \text{ m/s}^2$$

$$\text{Deceleration phase } a_3 = \frac{V}{t_3} = \frac{1}{1} = 1 \text{ m/s}^2$$

b) The active loads are calculated per carriage

During the acceleration phase

Radial loads

$$F_{\text{BeschZ1}} = F_{\text{BeschZ4}} = \frac{mg}{4} - \frac{m * a_1 * l_6}{2 * l_0} = \frac{150 * 9,8}{4} - \frac{150 * 1 * 500}{2 * 600} = 305 \text{ N}$$

$$F_{\text{BeschZ3}} = F_{\text{BeschZ2}} = \frac{mg}{4} + \frac{m * a_1 * l_6}{2 * l_0} = \frac{150 * 9,8}{4} + \frac{150 * 1 * 500}{2 * 600} = 430 \text{ N}$$

Tangential loads

$$F_{\text{BeschY1}} = F_{\text{BeschY2}} = F_{\text{BeschY3}} = F_{\text{BeschY4}} = \frac{m * a_1 * l_5}{2 * l_0} = \frac{150 * 1 * 150}{2 * 600} = 18,75 \text{ N}$$

At constant velocity

Radial loads

$$F_{\text{KonstZ1}} = F_{\text{KonstZ2}} = F_{\text{KonstZ3}} = F_{\text{KonstZ4}} = \frac{mg}{4} = \frac{150 * 9,8}{4} = 367,5 \text{ N}$$

During the deceleration phase

Radial loads

$$F_{\text{VerzZ1}} = F_{\text{VerzZ4}} = \frac{mg}{4} + \frac{m * a_3 * l_6}{2 * l_0} = \frac{150 * 9,8}{4} + \frac{150 * 1 * 500}{2 * 600} = 430 \text{ N}$$

$$F_{\text{VerzZ2}} = F_{\text{VerzZ3}} = \frac{mg}{4} - \frac{m * a_3 * l_6}{2 * l_0} = \frac{150 * 9,8}{4} - \frac{150 * 1 * 500}{2 * 600} = 305 \text{ N}$$

Tangential loads

$$F_{\text{VerzY1}} = F_{\text{VerzY2}} = F_{\text{VerzY3}} = F_{\text{VerzY4}} = \frac{m * a_3 * l_5}{2 * l_0} = \frac{150 * 1 * 150}{2 * 600} = 18,75 \text{ N}$$

c) The equivalent radial and tangential loads are calculated per carriage according to [2.8].

During the acceleration phase

$$F_{BeschE1} = F_{BeschE4} = |F_{BeschZ1}| + |F_{BeschY1}| = 323,75 \text{ N}$$

$$F_{BeschE2} = F_{BeschE3} = |F_{BeschZ2}| + |F_{BeschY2}| = 448,75 \text{ N}$$

At constant velocity

$$F_{KonstE1} = F_{KonstE2} = F_{KonstE3} = F_{KonstE4} = 367,5 \text{ N}$$

During the deceleration phase

$$F_{VerzE1} = F_{VerzE4} = |F_{VerzZ1}| + |F_{VerzY1}| = 448,75 \text{ N}$$

$$F_{VerzE2} = F_{VerzE3} = |F_{VerzZ2}| + |F_{VerzY2}| = 323,75 \text{ N}$$

d) The static safety factor for the maximum load on the Linear Guide during the acceleration and deceleration phase is calculated according to [2.1].

$$f_s = \frac{C_0}{F_{0MAX}} = \frac{41.070}{448,75} = 91,5$$

e) The active, dynamic, equivalent load is calculated according to [2.9].

$$F_{m1} = F_{m4} = \sqrt[3]{\frac{1}{S} (F_{BeschE1}^3 * S_1 + F_{KonstE1}^3 * S_2 + F_{VerzE1}^3 * S_3)} =$$

$$= \sqrt[3]{\frac{1}{4.000} * (323,75^3 * 1.000 + 367,5^3 * 2.000 + 448,75^3 * 1.000)} = 382,3 \text{ N}$$

$$F_{m2} = F_{m3} = \sqrt[3]{\frac{1}{S} (F_{BeschE2}^3 * S_1 + F_{KonstE2}^3 * S_2 + F_{VerzE2}^3 * S_3)} =$$

$$= \sqrt[3]{\frac{1}{4.000} * (448,75^3 * 1.000 + 367,5^3 * 2.000 + 323,75^3 * 1.000)} = 382,3 \text{ N}$$

f) The service life time of the four carriages is calculated according to [2.5].

$$L = \left(\frac{C}{F_{m1}} * \frac{f_H * f_T * f_C}{f_w} \right)^3 * 5 * 10^4 = \left(\frac{24.850}{382,3} * \frac{1}{2,0} \right)^3 * 5 * 10^4 = 1.716.509.860 \text{ m} = 1.716.510 \text{ km}$$

2.8 Preload/rigidity

2.8.1 Preload classes

Linear Guides can be preloaded to increase the rigidity of the system or to improve the spring compression behaviour of the total system. The elastic deformation of the raceways and the balls under load is smaller for preloaded carriages than in non-preloaded ones. The disadvantages of preloaded systems are: increased driving resistance and a resulting reduction in service life time. The preload is not considered in the normal service life time calculation when it is within the ranges specified in Table 2.6. The preload in a Linear Guide system is achieved by using rolling elements that are oversized by a specific factor (Figure 2.17).

The preload is defined by the radial clearance resulting from the over sizing of the rolling elements.

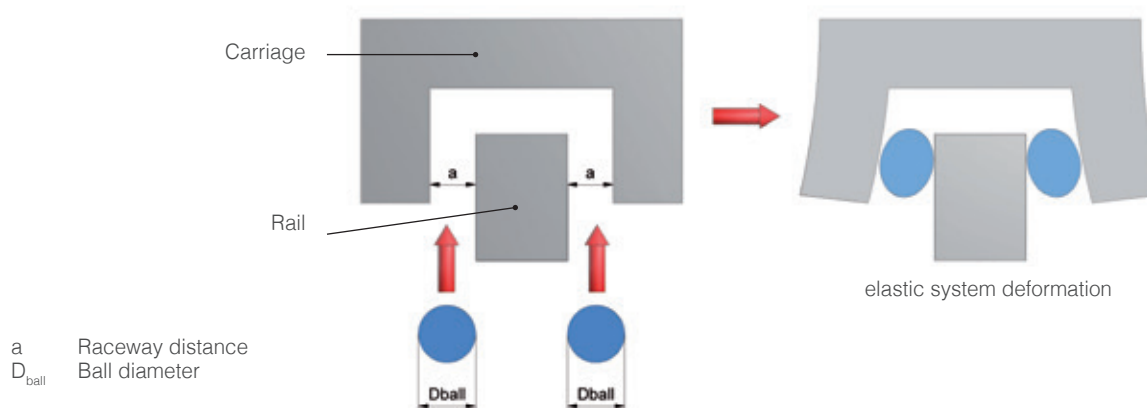

Figure 2.17 Preloading by over sizing of the balls

SNR Linear Guides are produced in different preload classes (Table 2.7). The individual preload classes correspond to a preload of the rolling elements that is defined by a percentage rate of the dynamic load rating C.

Table 2.7 Preload classes

	Description	Preload class
No preload	Z0	0
Low preload	Z1	up to 2% of C
Medium preload	Z2	up to 4% of C
High preload	Z3	up to 8% of C
Special preload	Zx	According customer request

Example for the selection of the preload class

Table 2.8 Application areas for different preload classes

	Without preload (Z0)	Low preload (Z1)	Medium and high preload (Z2/Z3)
Application conditions	<ul style="list-style-type: none"> ▶ Two-rail system ▶ Weak external effects ▶ Low load ▶ Low friction ▶ Low accuracy 	<ul style="list-style-type: none"> ▶ One-rail system ▶ Low load ▶ High accuracy ▶ Self-supporting design ▶ High dynamics 	<ul style="list-style-type: none"> ▶ Strong vibrations ▶ High-performance processing ▶ Strong external effects
Applications	<ul style="list-style-type: none"> ▶ Welding machines ▶ Cutting machines ▶ Feeding systems ▶ Tool changer ▶ X and Y axes for general industrial applications ▶ Packaging machines 	<ul style="list-style-type: none"> ▶ Precision coordinate tables ▶ Manipulators ▶ Z-axes for general industrial applications ▶ Measuring devices ▶ PC-board drilling machines 	<ul style="list-style-type: none"> ▶ Processing centres ▶ NC turning machine ▶ Milling machines ▶ Grinding machines

Table 2.9 Radial clearance of Standard Linear Guides [μm]

Type	Z0	Z1	Z2	Z3
LGB_15 B_/F_	-3...+3	-8...-4	-13...-9	-18...-14
LGB_20 B_/F_	-3...+3	-8...-4	-14...-9	-19...-14
LGB_25 B_/F_	-4...+4	-10...-5	-17...-11	-23...-18
LGB_30 B_/F_	-4...+4	-11...-5	-18...-12	-25...-19
LGB_35 B_/F_	-5...+5	-12...-6	-20...-13	-27...-20
LGB_45 B_/F_	-6...+6	-15...-7	-23...-15	-32...-24
LGB_55 B_/F_	-7...+7	-19...-8	-29...-20	-38...-30

Table 2.10 Radial clearance of wide Standard Linear Guides

Type	Z0	Z1	Z2
LGBXH21 TN/WN	-3...+3	-8...-4	-13...-9
LGBXH27 TN/WN	-3...+3	-9...-4	-14...-10
LGBXH35 TN/WN	-4...+4	-11...-5	-18...-12

Table 2.11 Radial clearance of Miniature guides

Type	Z0	Z1	Type	Z0	Z1
LGMX07 B_	+1...+2	-3...0			
LGMX09 B_	+1...+2	-4...0	LGMC09 B_	+1...+2	-4...0
LGMX12 B_	+1...+3	-6...0	LGMC12 B_	+1...+3	-6...0
LGMX15 B_	+1...+5	-10...0	LGMC15 B_	+1...+5	-10...0
LGMX09 W_	+1...+2	-4...0	LGMC09 W_	+1...+2	-4...0
LGMX12 W_	+1...+3	-6...0	LGMC12 W_	+1...+3	-6...0
LGMX15 W_	+1...+5	-10...0	LGMC15 W_	+1...+5	-10...0

We recommend that you contact our application engineers to select the optimal preload.

2.8.2 Rigidity

The rigidity of a carriage is defined by the relationship between the external load and the resulting elastic deformation in the load direction. The rigidity is an important parameter for the selection of the system, as the rigidity values vary according to the type and version of the SNR Linear Guide systems. The rigidity values discriminate between deformation due to load in the main load directions (Figure 2.18) and angular deformation due to torque load (Figure 2.19).

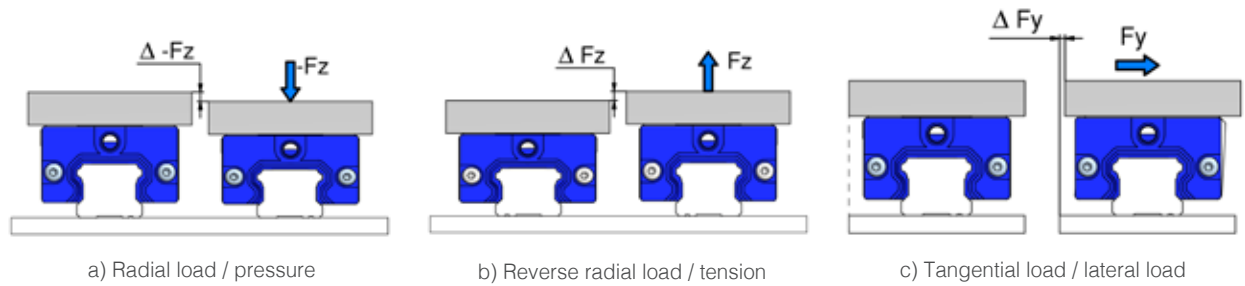

Figure 2.18 Deformation due to load in the main load directions

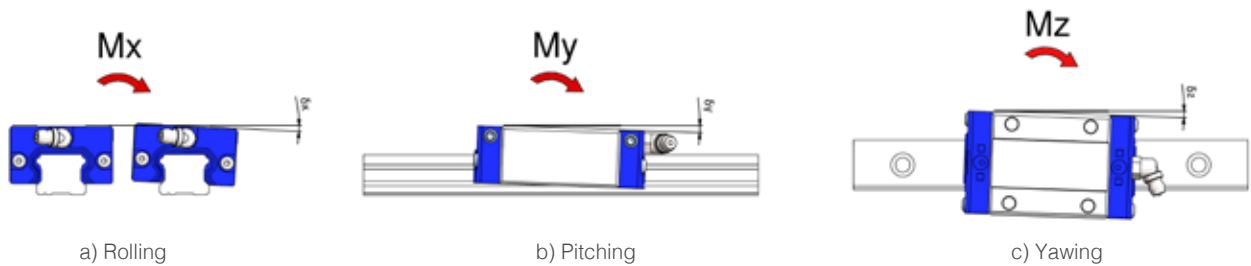

Figure 2.19 Angular deformation due to torque load

2.9. Precision

2.9.1 Precision classes

SNR Linear Guides are produced in various precision classes. Each precision class has a maximum deviation for running parallelism and maximum dimensional deviations. (Figure 2.20).

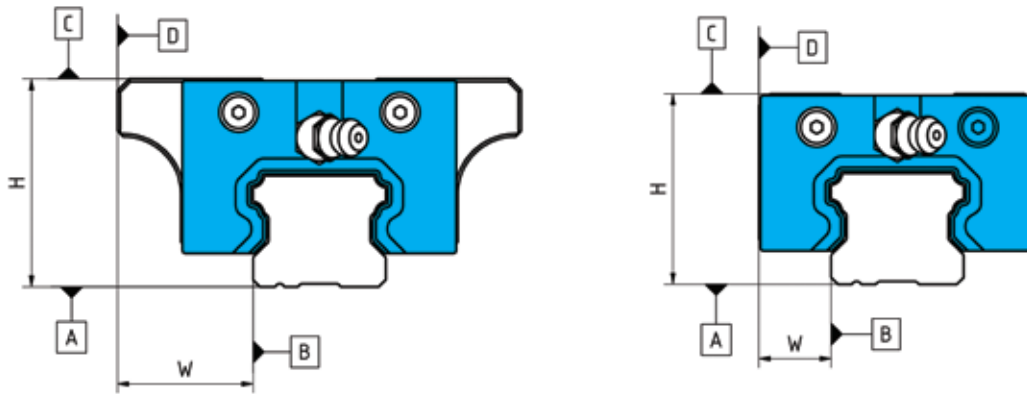

Figure 2.20 Precision classes

The running parallelism ΔC describes the maximum parallelism deviation between the top of the carriage and the bottom of the rail, relative to the length of the rail. ΔD is the maximum parallelism deviation between the lateral reference surface of the carriage and the rail, relative to the length of the rail. The height tolerance is the maximum dimensional deviation of the height measurement H in the z -direction between the top of the carriage and the bottom of the rail. The maximum dimensional deviation between the lateral reference surface of the carriage and the rail in y -direction is the tolerance of the value W . The values for the individual precision classes are provided in Table 2.12 for the standard Linear Guides and in Table 2.13 for the miniature guides.

Table 2.12 Precision classes of the standard guides

	Normal precision (N)	H precision (H)	P precision (P)	Super precision (S)	Ultra precision (U)
Height tolerance (H)	$\pm 0,1$	$\pm 0,04$	0 -0,04	0 -0,02	0 -0,01
Width tolerance (W)	$\pm 0,1$	$\pm 0,04$	0 -0,04	0 -0,02	0 -0,01
Height difference (ΔH) *	0,03	0,02	0,01	0,005	0,003
Width difference (ΔW) *	0,03	0,02	0,01	0,005	0,003
Running parallelism between carriage surface C and the rail surface A	See Figure 2.21.				
Running parallelism between the carriage reference surface D and the rail reference surface B	See Figure 2.21.				

* between two carriages

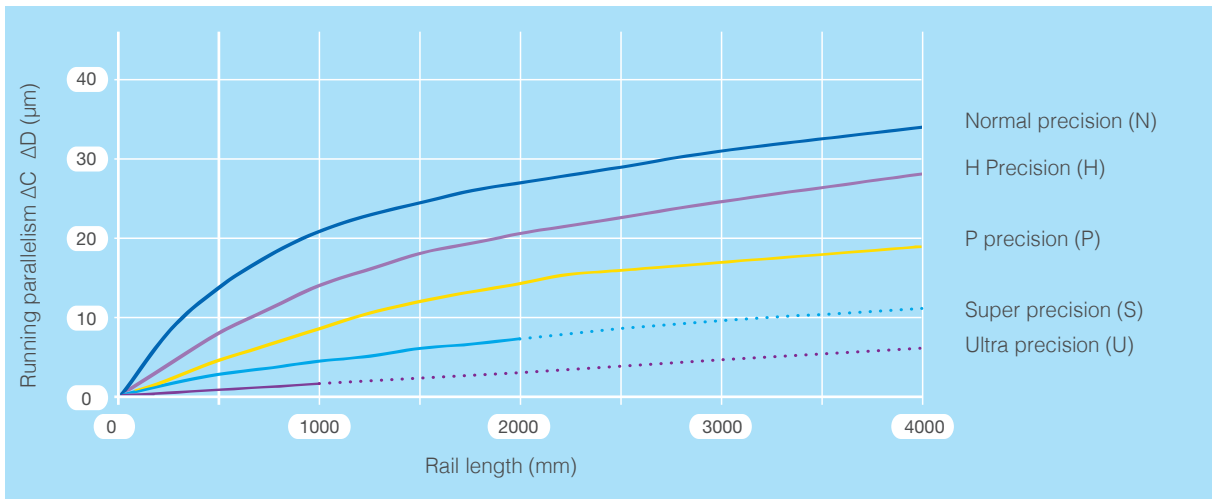

Figure 2.21 Running parallelism of the standard linearguides

Table 2.13 Precision classes of the miniature guides

	Normal precision (N)	H precision (H)	P precision (P)(U)
Height tolerance (H)	± 0,4	± 0,02	0 -0,01
Width tolerance (W)	± 0,4	± 0,025	0 -0,015
Height difference (ΔH) *	0,03	0,015	0,007
Width difference (ΔW) *	0,03	0,02	0,01
Running parallelism between carriage surface C and the rail surface A	See Figure 2.22.		
Running parallelism between the carriage reference surface D and the rail reference surface B	See Figure 2.22.		

* between two carriages

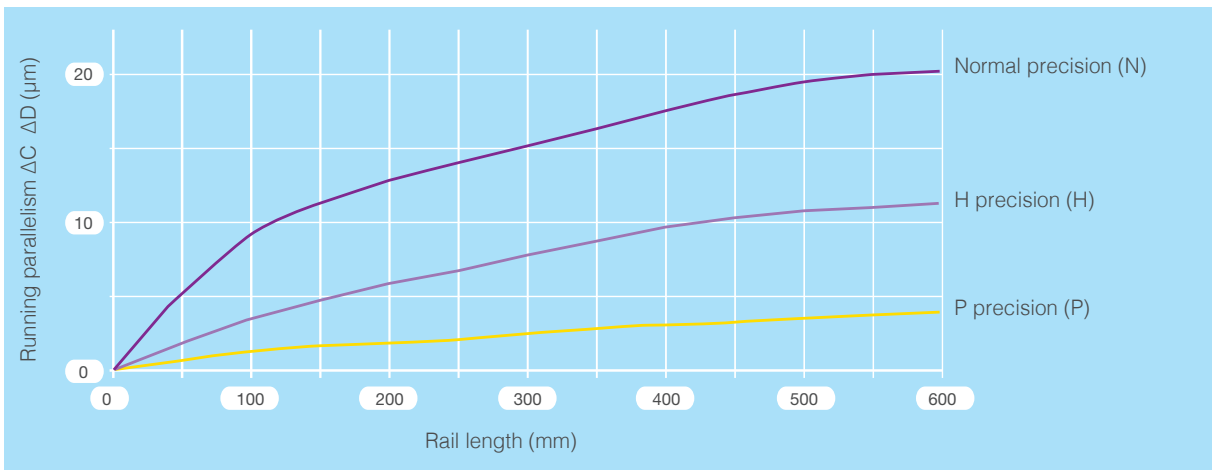

Figure 2.22 Running parallelism of the miniature guides

2.9.2 Interchangeability

It is not possible to make the SNR Linear Guides in all precision and preload classes interchangeable, as this would interfere with our goal of ensuring top quality. High precision and preload classes are therefore only available as sets consisting of rails and carriages. Table 2.14 contains an overview of the exchange options.

Table 2.14 Interchangeability of standard Linear Guides

Precision class		interchangeable			not interchangeable				
		N	H	P*	N	H	P	S	U
Preload class	LGB	Z0	Z0	Z0	-	-	-	-	-
		Z1	Z1	Z1	-	-	-	Z1	Z1
		Z2	Z2	Z2	-	-	-	Z2	Z2
		-	-	-	Z3	Z3	Z3	Z3	Z3
		-	-	-	ZX	ZX	ZX	ZX	ZX
	LGM	Z0*	-	-	-	Z0	Z0	-	-
		Z1*	-	-	-	Z1	Z1	-	-
		-	-	-	ZX	ZX	ZX	-	-

* on request

2.9.3 Error compensation

Each component and each support structure on which Linear Guides are to be mounted has straightness, evenness and parallelism variance. Inaccuracies also occur as a result of installation faults. A significant number of these errors can be compensated for by the special raceway geometry with DF configuration of the SNR Linear Guides, as long as the supporting structure is sufficiently rigid (Figure 2.23).

The error compensation effect usually improves the running accuracy of a machine table by more than 80% compared with the initial surfaces.

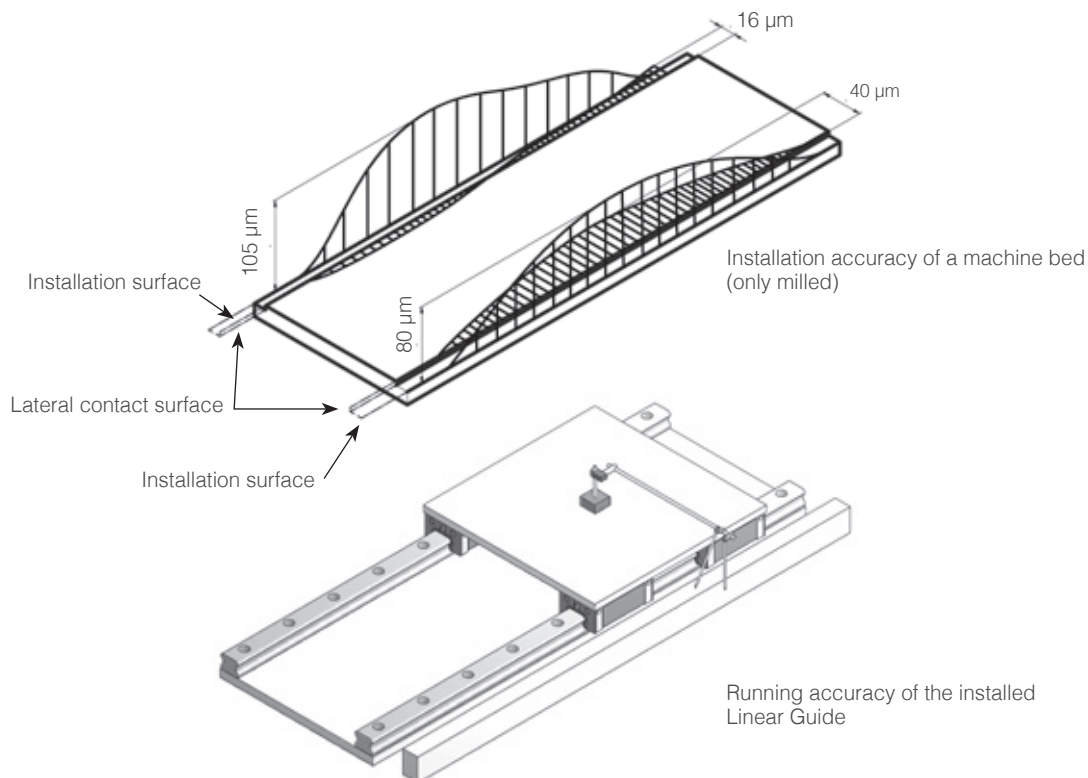

Figure 2.23 Error compensation

2.10 Drive power

2.10.1 Friction

Linear Guides basically consist of a carriage, a rail and rolling elements that move between the raceways of the carriage and the rail. A friction force F_R occurs, as with any movement (Figure 2.24).

The friction coefficient (μ) is mainly affected by the following factors:

- Load (F)
- Preload
- Osculation
- Design principle (circular arc groove or Gothic arc groove)
- Rolling element shape
- Material combinations in the runner block
- Lubricant

The stick-slip effect at start-up, so familiar with sliding guides, hardly occurs.

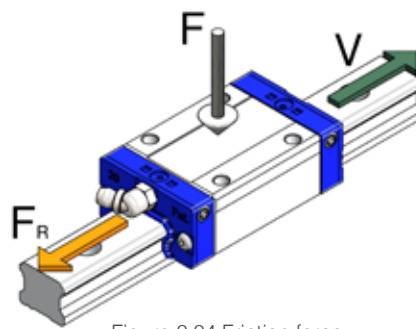

Figure 2.24 Friction force

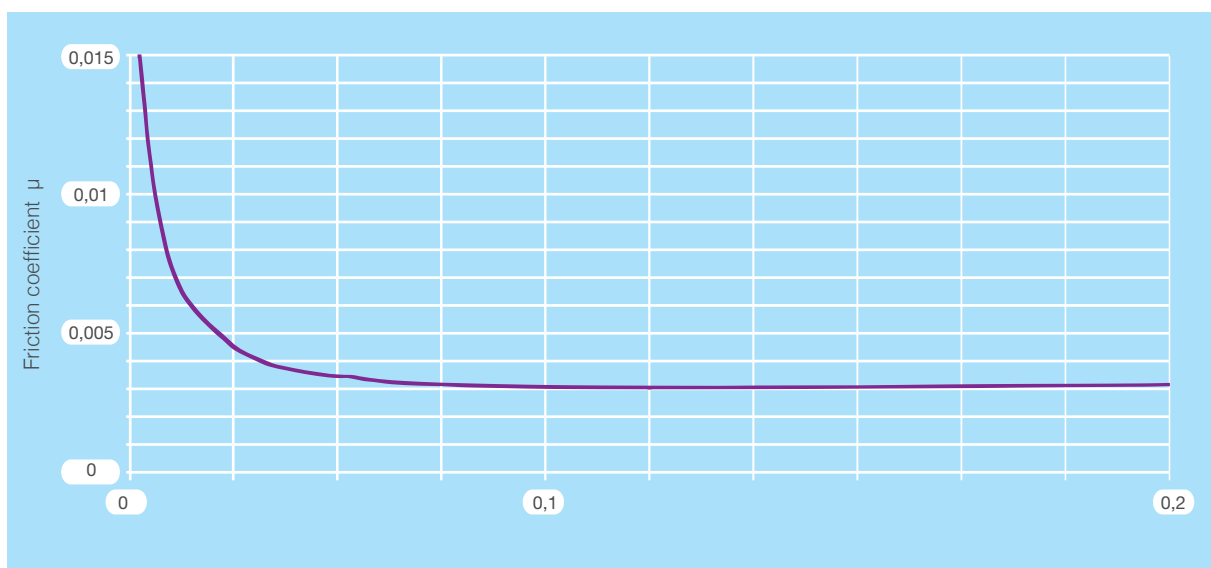

Figure 2.25 Ratio of load / friction coefficient of Linear Guides with balls

SNR Linear Guides with balls as rolling elements have a friction coefficient (μ) of approx. 0.003 (Figure 2.25). The forces acting on the system include internal as well as external forces. The external forces may be weight forces, process forces (e.g. milling forces) and dynamic forces (e.g. acceleration forces). Internal forces result from preload, assembly tolerances and installation faults.

The friction caused by the lubricant strongly depends on the properties of the lubricant used. Immediately after re-lubrication, the friction forces of a Linear Guide increase for a short time. After some rolling movements of the rolling elements, the optimal grease distribution of the system is again reached and the friction force drops to its normal value.

2.10.2 Driving resistance

The driving resistance of a Linear Guide consists of the friction force and the sealing resistance (Figure 2.26).

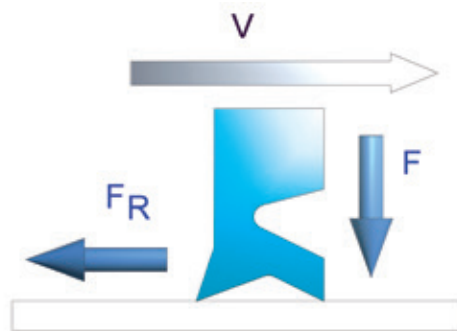

Figure 2.26 Friction force of a two-lip seal

The seal resistance is in turn dependent on the respective combination of seals used. The standard configuration of SNR Linear Guides includes an inner seal (not for miniature guides and wide standard Linear Guides), two side seals and end seals on both sides. All seals are implemented as two-lip seals. The maximum sealing resistances are shown in Table 2.15.

Table 2.15 Maximum sealing resistances

Series	Sealing resistance [N]	Series	Sealing resistance [N]
LGB__15 BS/FS	2,6	LGBXH21 TN/WN	3,3
LGB__15 BN/FN	3,3	LGBXH27 TN/WN	4,9
LGB__15 BL/FL	3,3	LGBXH35 TN/WN	7,8
LGB__20 BS/FS	2,8		
LGB__20 BN/FN	3,7	LGM_07 BN	0,2
LGB__20 BL/FL	4,6	LGM_09 BN	0,3
LGB__20 BE/FE	4,9	LGM_09 BL	0,4
LGB__25 BS/FS	5,2	LGM_12 BN	0,7
LGB__25 BN/FN	5,4	LGM_12 BL	0,8
LGB__25 BL/FL	6,4	LGM_15 BN	0,9
LGB__25 BE/FE	6,5	LGM_15 BL	1,0
LGB__30 FS	7,8		
LGB__30 BN/FN	7,8	LGM_09 WN	0,4
LGB__30 BL/FL	7,8	LGM_09 WL	0,5
LGB__30 BE/FE	7,8	LGM_12 WN	0,8
LGB__35 FS	11,2	LGM_12 WL	0,9
LGB__35 BN/FN	11,2	LGM_15 WN	1,1
LGB__35 BL/FL	11,2	LGM_15 WL	1,2
LGB__35 BE/FE	11,2		
LGB__45 BN/FN	14,0		
LGB__45 BL/FL	14,0		
LGB__45 BE/FE	14,0		
LGB__55 BN/FN	14,0		
LGB__55 BL/FL	14,0		
LGB__55 BE/FE	14,0		

2.10.3 Driving force

The driving force for a Linear Guide system (Figure 2.27) is calculated according to the following formula:

$$F_a = \mu \cdot F + n \cdot f \quad [2.13]$$

- F_a : Driving force [N]
- μ : Friction coefficient
- F : Load [N]
- n : Number of carriages
- f : Specific driving resistance of a carriage [N]

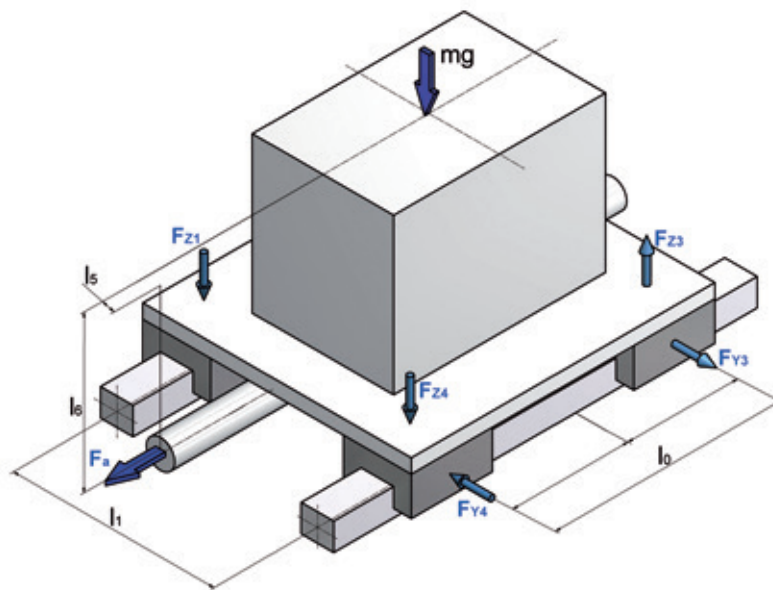

Figure 2.27 Driving force calculation

The maximum driving resistances shown in the Tables 2.16 and 2.17 result for SNR Linear Guides with standard sealing and greasing at room temperature and without load. This value may vary considerably when different sealing options or grease types are chosen.

Table 2.16 Driving resistances Standard Linear Guide

Series	Z0 [N]	Z1 [N]	Z2 [N]	Z3 [N]
LGBC_15 BS/FS	4,5	4,9	5,3	5,9
LGBC_15 BN/FN	5,7	6,5	7,1	8,3
LGBC_15 BL/FL	6,5	7,5	8,6	10,4
LGBC_20 BS/FS	5,2	5,8	6,3	7,2
LGBC_20 BN/FN	6,7	7,8	8,9	10,7
LGBC_20 BL/FL	8,0	9,5	10,9	13,1
LGBC_20 BE/FE	8,6	10,4	12,1	14,7
LGBC_25 BS/FS	8,1	8,7	9,6	10,8
LGBC_25 BN/FN	9,1	10,6	12,3	14,5
LGBC_25 BL/FL	10,6	12,5	14,7	17,6
LGBC_25 BE/FE	11,3	13,4	15,7	19,1
LGBC_30_FS	11,2	12,3	13,4	15,1
LGBC_30 BN/FN	12,4	14,7	17,0	20,5
LGBC_30 BL/FL	13,0	16,0	19,0	23,4
LGBC_30 BE/FE	13,5	16,7	20,1	25,1
LGBC_35_FS	15,1	16,7	18,4	20,7
LGBC_35 BN/FN	17,1	20,1	23,4	28,2
LGBC_35 BL/FL	17,9	21,6	25,7	31,8
LGBC_35 BE/FE	18,5	22,6	27,1	33,8
LGBC_45 BN/FN	21,0	25,2	29,5	36,0
LGBC_45 BL/FL	21,8	26,8	32,0	39,7
LGBC_45 BE/FE	22,7	28,4	34,4	43,3
LGBC_55 BN/FN	23,7	28,5	33,9	41,6
LGBC_55 BL/FL	26,2	32,6	39,9	50,3
LGBC_55 BE/FE	29,1	37,9	47,8	61,9
LGBX_15 BS/FS	4,1	4,5	4,9	5,5
LGBX_15 BN/FN	5,1	5,9	6,6	7,7
LGBX_15 BL/FL	5,2	6,1	6,9	8,3
LGBX_20 BS/FS	4,6	5,2	5,8	6,6
LGBX_20 BN/FN	5,8	7,0	8,0	9,8
LGBX_20 BL/FL	6,9	8,4	9,8	12,1
LGBX_20 BE/FE	7,4	9,1	10,8	13,4
LGBX_25 BS/FS	7,4	8,1	8,9	10,1
LGBX_25 BN/FN	8,1	9,5	11,2	13,5
LGBX_25 BL/FL	9,4	11,2	13,4	16,3
LGBX_25 BE/FE	9,7	11,7	14,1	17,4
LGBX_30_FS	10,4	11,5	12,6	14,3
LGBX_30 BN/FN	11,2	13,4	15,8	19,2
LGBX_30 BL/FL	11,5	14,3	17,5	21,9
LGBX_30 BE/FE	11,8	15,1	18,4	23,4
LGBX_35_FS	14,3	15,8	17,5	19,8
LGBX_35 BN/FN	15,4	18,5	21,7	26,5
LGBX_35 BL/FL	16,0	19,7	23,9	29,9
LGBX_35 BE/FE	16,3	20,4	24,9	31,6
LGBX_45 BN/FN	19,3	23,5	27,8	34,3
LGBX_45 BL/FL	19,9	24,9	30,1	37,8
LGBX_45 BE/FE	20,6	26,3	32,3	41,2
LGBX_55 BN/FN	20,5	25,3	30,7	38,3
LGBX_55 BL/FL	21,9	28,3	35,6	46,0
LGBX_55 BE/FE	23,7	32,5	42,5	56,5

Table 2.17 Driving resistances wide Standard Linear Guide

Series	Z0 [N]	Z1 [N]	Z2 [N]
LGBXH21TN/WN	5,2	6,1	6,9
LGBXH27TN/WN	6,9	8,4	9,8
LGBXH35TN/WN	11,5	14,3	17,5

3 Installation

3.1 Arrangement of the installation surface

The most common arrangement consist of two rails arranged in parallel with one or several carriages per rail. The example shown is a common application, in which the guides are fastened at a specific distance to each other on an even support surface (e.g. a machine bed) and in which a machine table is attached to the carriages (Figure 3. 1).

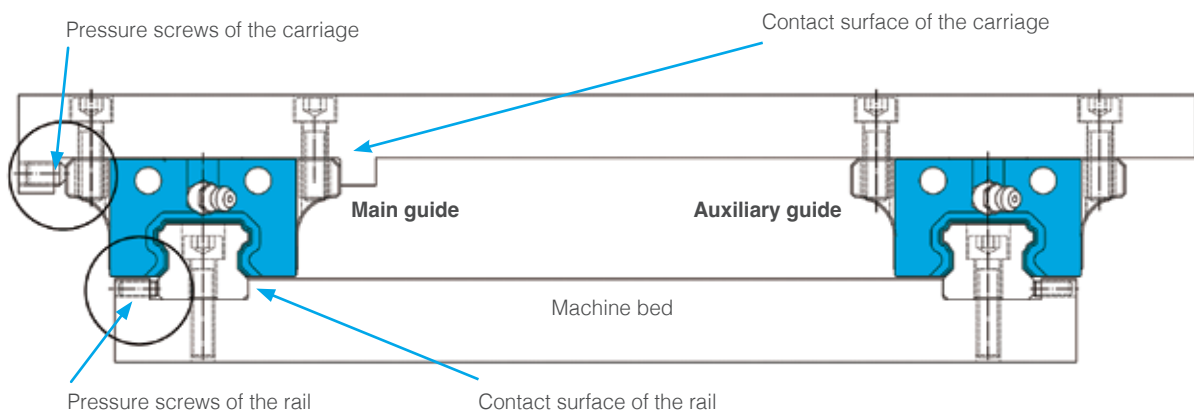

Figure 3.1 Installation of two parallel arranged Linear Guides

The installation edges are used to achieve accurate positioning during installation. The installation edges also make the installation of the whole system easier. The information about the height of the installation edge H_r for the rail guide (Figure 3.2) and the height of the installation edge H_s for the carriage (Figure 3.3) is provided in Table 3.1 to Table 3.3.

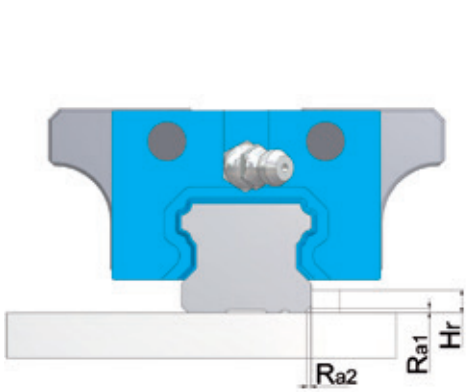

Figure 3.2. Locating edge of the carriages

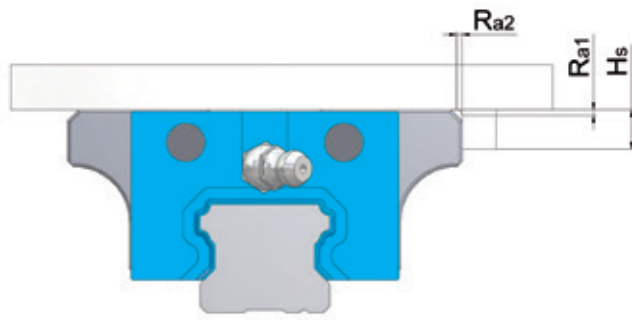

Figure 3.3. Locating edge of the carriages

Table 3.1 Installation edges and edge radius for Standard Linear Guides.

Type	Edge radius Ra1=Ra2 [mm]	Installation edge Hr [mm]	Installation edge Hs [mm]	Fastening screws*
LGB_15 B_/F_	0,6	3,1	5	M4x16
LGB_20 B_/F_	0,9	4,3	6	M5x20
LGB_25 B_/F_	1,1	5,6	7	M6x25
LGB_30 B_/F_	1,4	6,8	8	M8x30
LGB_35 B_/F_	1,4	7,3	9	M8x30
LGB_45 B_/F_	1,6	8,7	12	M12x35
LGB_55 B_/F_	1,6	11,8	14	M14x35

* Minimum screw length

Table 3.2 Installation edge and edge radius for wide Standard Linear Guides.

Type	Edge radius Ra1=Ra2 [mm]	Installation edge Hr [mm]	Installation edge Hs [mm]	Fastening screws*
LGBXH21 TN/WN	0,2	2,5	5,0	M5x20
LGBXH27 TN/WN	0,2	2,5	7,0	M6x25
LGBXH35 TN/WN	0,3	3,2	9,0	M8x30

* Minimum screw length

Table 3.3 Installation edges and edge radius for Miniature guides.

Type	Edge radius Ra1 [mm]	Edge radius Ra2 [mm]	Installation edge Hr [mm]	Installation edge Hs [mm]	Fastening screws*
LGM_07B	0,1	0,3	1,0	3,0	M2x5
LGM_09B	0,1	0,3	1,5	4,9	M3x6
LGM_12B	0,3	0,2	1,5	5,7	M3x6
LGM_15B	0,3	0,4	3,3	6,5	M3x8
LGM_09W	0,1	0,5	2,5	4,9	M3x6
LGM_12W	0,3	0,3	2,5	5,7	M3x8
LGM_15W	0,3	0,3	3,3	6,5	M3x8

* Minimum screw length

3.2 Marking of Linear Guides

In the use of Linear Guides with precision classes P and higher, that are installed in one plane (main guide and auxiliary guide) all carriages are marked with the same production code (Figure 3.4).

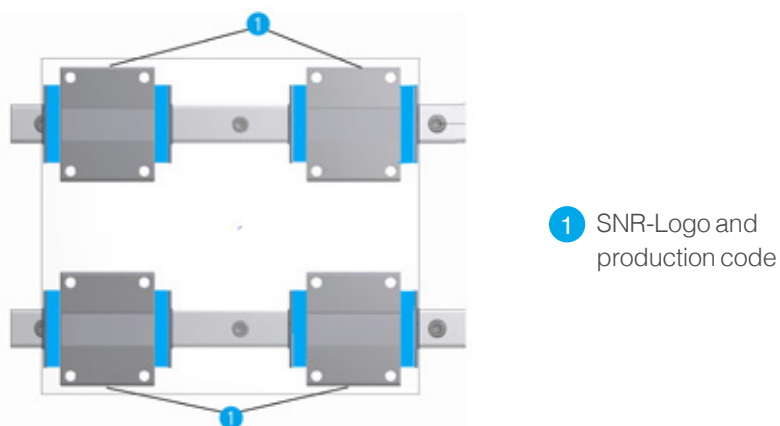

Figure 3.4 Marking the main and auxiliary guide

For accurate positioning in the adjacent construction carriages and guides respectively have a machined reference surface. The reference surfaces of the carriage are located on the side that is opposite the SNR logo / production code. The reference surface of the rail is marked by the narrow marking line at the bottom. Both reference surfaces exhibit when correctly installed in the same direction. (Figure 3.5).

We recommend that you contact our application engineers when a different arrangement of the reference surfaces is required.

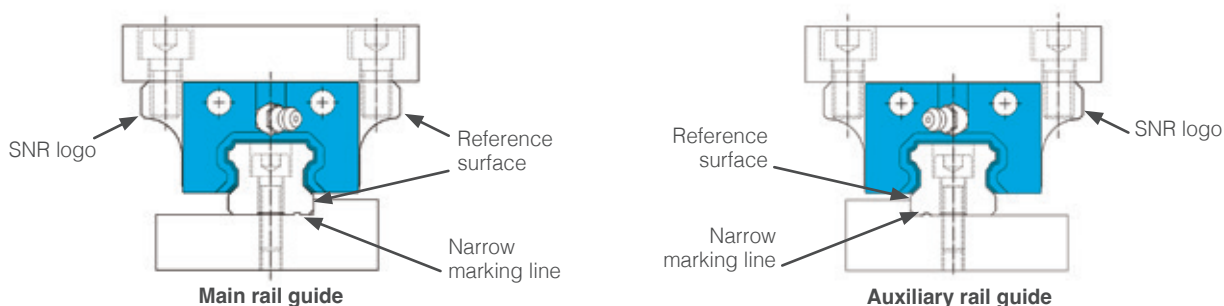

Figure 3.5 Marking the reference surfaces

Applications may require rail lengths that exceed the maximum segment length or require a rail segmentation for technical reasons. These jointed rails are supplied in rail segments which can be mounted in any order. The rail joints are marked with «J» (Figure 3.6).



Figure 3.6 Marking of jointed rails

3.3 Arrangement of Linear Guides

The following examples show some basic arrangements of Linear Guides that are most commonly used in practical applications (Figure 3.7).

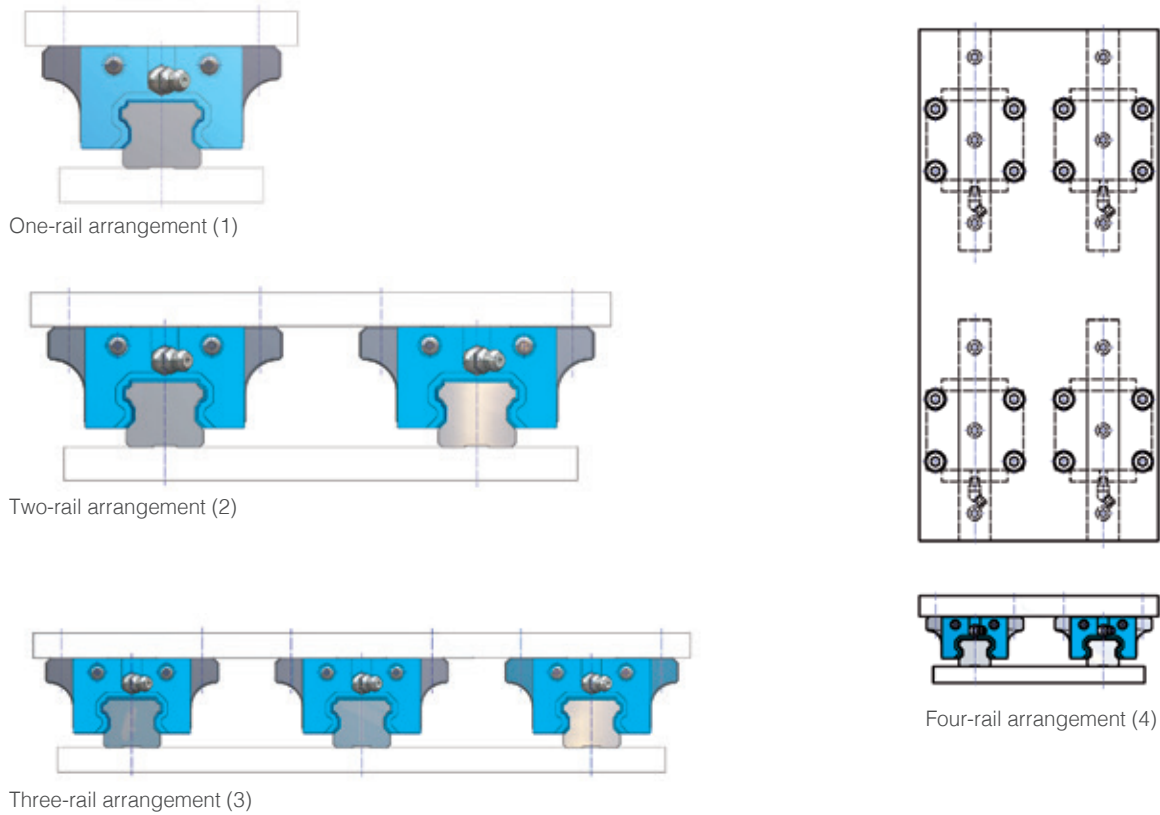

Figure 3.7 Examples for the arrangement of Linear Guides

The number of Linear Guides and the carriages in a total system has an impact on the rigidity, load capacity and dimensions of the application. The arrangement of the Linear Guides also determines the requirements for the accuracy of the installation surfaces. The actual arrangement of Linear Guides strongly depends on the application and may therefore vary accordingly.

3.4 Installation position of Linear Guides

The installation position of the Linear Guides system (carriage and rail) is defined by the basic concept of the machine/ device (Figure 3.8). The lubrication process (lubricants, lubrication intervals, supply with lubricant) must be adapted to the installation position selected.

Rotation around the X-axis

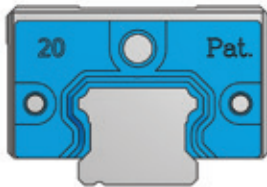

Horizontal installation
without rotation
x - 0°

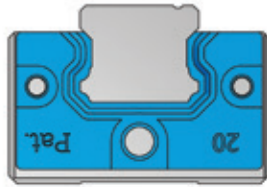

Overhead installation,
rotation by 180°
x - 180°



Tilted installation,
rotation by 0 to 180°
x - ...°

Rotation around the Y-axis



Horizontal installation
without rotation
y - 0°

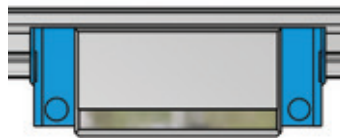

Overhead installation,
rotation by 180°
y - 180°

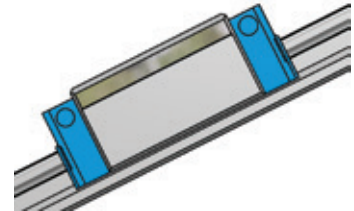

Tilted installation,
rotation by 0 to 180°
y - ...°

Figure 3.8 Installation positions of a Linear Guides

3.5 Installation instructions

To assemble SNR Linear Guides properly and without affecting the safety and health of the personnel, the instructions and notes must be observed and followed.

- Linear Guides must be installed by authorized personnel.
- Appropriate tools and aids to be used for the assembly.
- Avoid temperature differences between the components to be assembled.
- The steps are to be performed in the specified order.
- To prevent corrosion of the material surfaces, installer are to wear cotton gloves when installing non-conserved components.
- Remove the components from the packaging at the installation site to avoid any contamination of the components.

Step 1. Cleaning the installation surface

- ▶ Remove unevenness, burrs and dirt with an oilstone from the installation surface
- ▶ Clean the SNR Linear Guides
- ▶ Remove the anti-corrosion oil e. g. with a cotton cloth

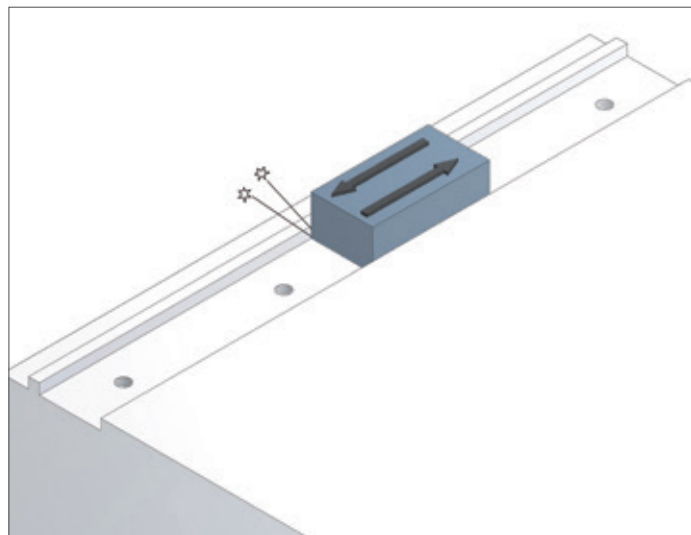

Figure 3.9 Preparation of the installation surface

Step 2. Alignment of the Linear Guide on the installation surface

- ▶ Place the rail onto the installation surface and fasten it slightly with the screws, so that the rail touches the installation surface
- ▶ Note the reference surface (marked with the narrow groove on the rail bottom)
- ▶ Align reference surface to the shoulder edge of the installation surface

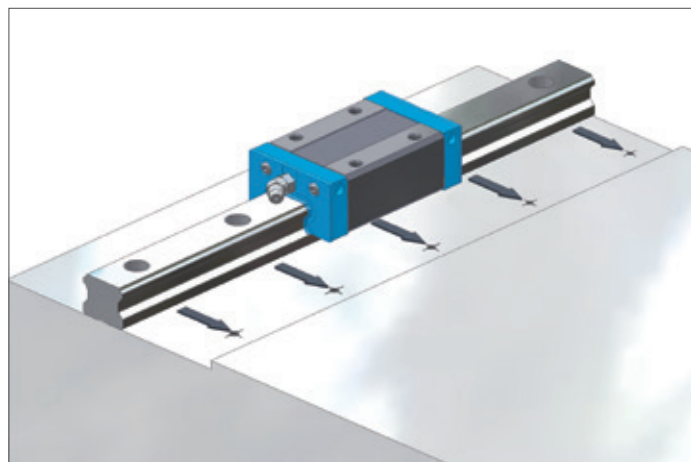

Figure 3.10 Aligning the Linear Guide

Step 3. Pre-installing the Linear Guide

- ▶ Slightly tighten the screws
- ▶ Align screw heads in the middle of the mounting holes from the rail
- ▶ Pre-assemble pressure screws

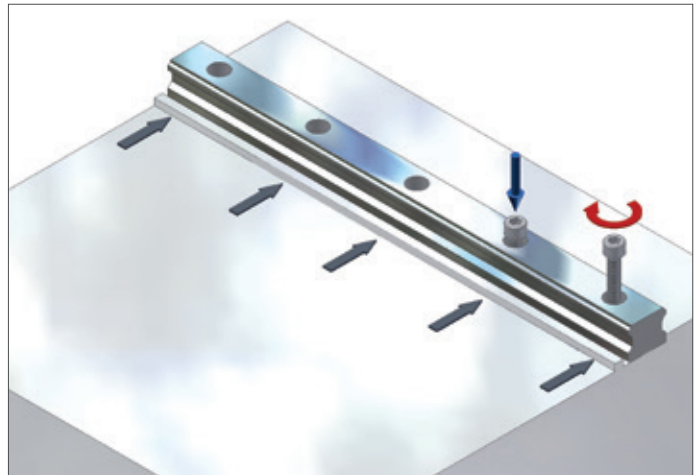

Figure 3.11 Pre-installing

Step 4. Fastening the pressure screws

- ▶ Tighten the pressure screws on the rail to achieve a lateral contact with the installation surface
- ▶ Note the necessary torque (chapter 3.7)
- ▶ Tighten the pressure screws sequentially by starting in the middle of the rail

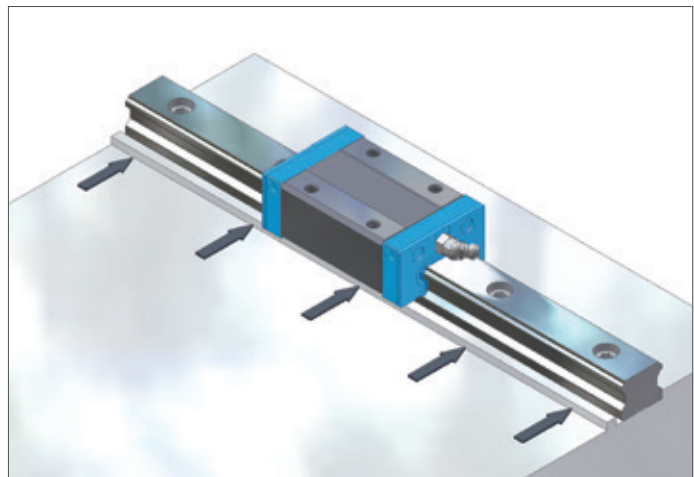

Figure 3.12 Positioning the rail

Step 5. Fastening the fastening screws with a torque wrench

- ▶ Tighten the mounting screws with the correct torque (chapter 3.7)
- ▶ Tighten the mounting screws sequentially by starting in the middle of the rail

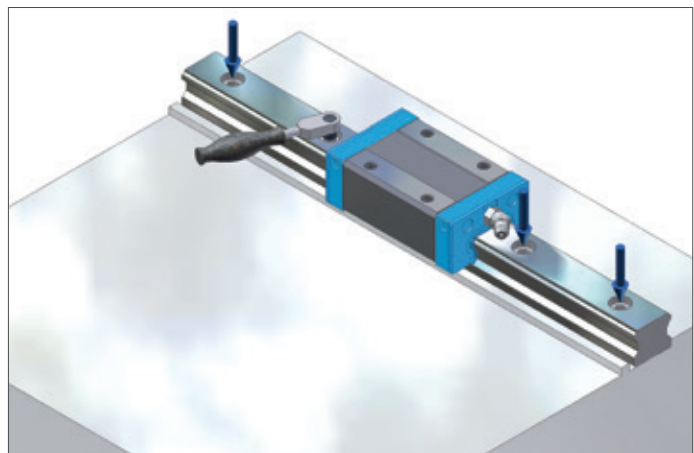

Figure 3.13 Final installation of the rail

Step 6. Installation of additional Linear Guides

Additional Linear Guides must be installed in the same order (Steps 1 to 5).

Step 7. Installation of the machine table

- ▶ Remove unevenness, burrs and dirt with an oilstone from the table plate
- ▶ Put the table carefully on the carriages and slightly tighten the mounting screws
- ▶ Position the table by using of the lateral pressure screws from the table plate
- ▶ Tighten the mounting screws of the table in the specified order (crosswise)
- ▶ Start on the reference side
- ▶ Note the necessary torque (chapter 3.7)

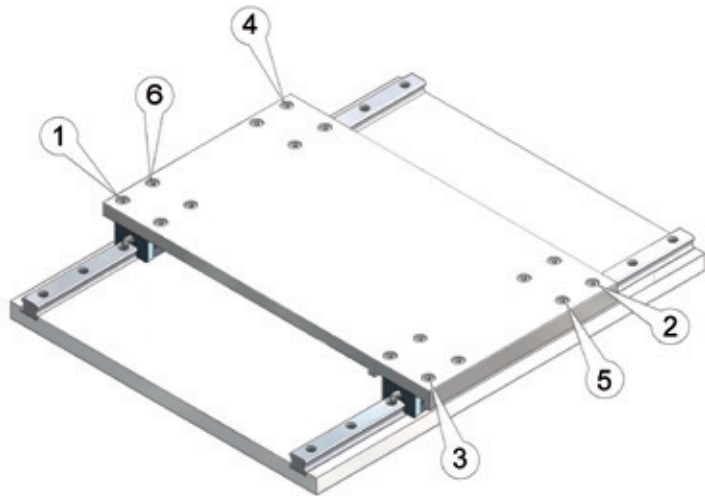

Figure 3.14 Fastening sequence for machine table installation

Step 8. Completing the assembly

- ▶ Assemble rail caps
- ▶ Conserve system

3.6 Permitted installation tolerances

The service life of the Linear Guide system under normal operating conditions is not affected when the installation tolerances specified are not exceeded.

Parallelism tolerance between two Linear Guides

The parallelism tolerance between two Linear Guides (Figure 3.15) depends on the Linear Guides series used and the accuracy of the machine required. The maximum parallelism tolerances are provided in Table 3.4 and Table 3.5.

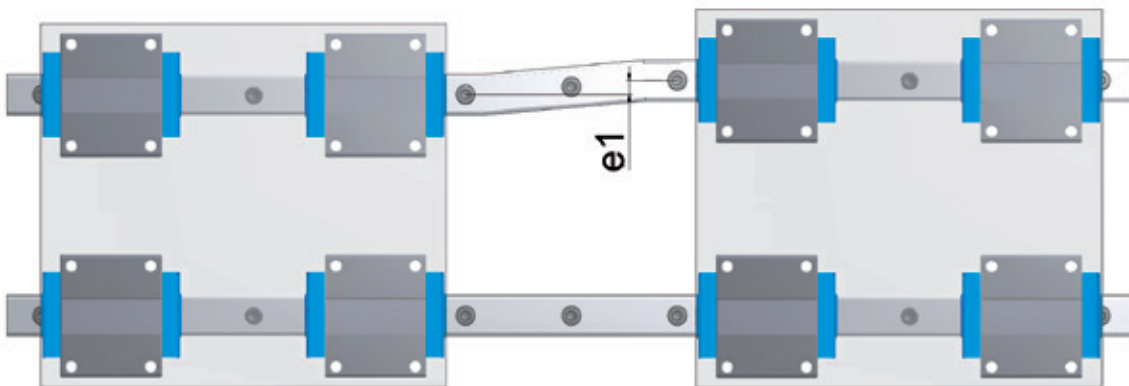

Figure 3.15 Parallelism tolerance between two Linear Guides e_1

Table 3.4 Parallelism tolerance e_1 for Standard Linear Guides

Type	e_1 [μm]			
	Z0	Z1	Z2	Z3
LGB_15 B_/F_	25	18	-	-
LGB_20 B_/F_	25	20	18	15
LGB_25 B_/F_	30	22	20	15
LGB_30 B_/F_	40	30	27	20
LGB_35 B_/F_	50	35	30	22
LGB_45 B_/F_	60	40	35	25
LGB_55 B_/F_	70	50	45	30
LGBXH21 TN/WN	25	18	-	-
LGBXH27 TN/WN	25	20	-	-
LGBXH35 TN/WN	30	22	20	-

Parallelism tolerance between two parallel Miniature guides

Table 3.5 Parallelism tolerance e_1 for Miniature guides

Type	e_1 [μm]	
	Z0	Z1
LGM_07 B_	3	1
LGM_09 B_	4	3
LGM_12 B_	9	5
LGM_15 B_	10	6

The values for the height tolerances (Figure 3.16) depend on the distance between the Linear Guides and are calculated using the calculation factor x (Table 3.6 and Table 3.7) and Formula [3.1].

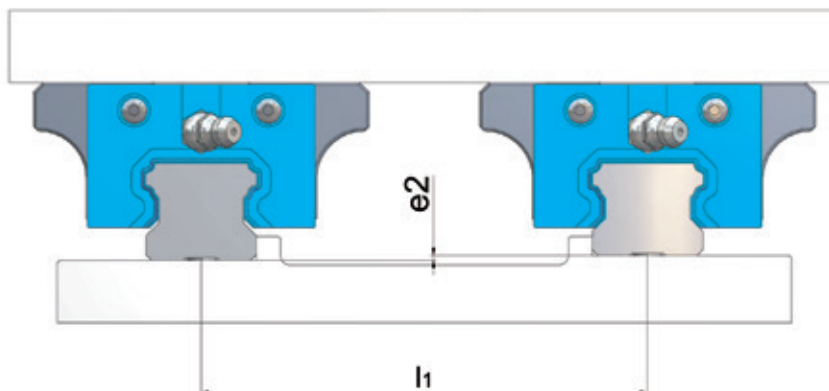

Figure 3.16 Height tolerance between two Linear Guides e_2

$$e_2 = l_1 * x \quad [3.1]$$

- e_2 Height tolerance of the mounting surface between two rails [μm]
 l_1 Distance between the rails [mm]
 x Calculation factors

Table 3.6 Calculation factors x for Standard Linear Guides

Type	x			
	Z0	Z1	Z2	Z3
LGB_15 B_/F_	0,26	0,17	0,10	-
LGB_20 B_/F_	0,26	0,17	0,10	0,08
LGB_25 B_/F_	0,26	0,17	0,14	0,12
LGB_30 B_/F_	0,34	0,22	0,18	0,16
LGB_35 B_/F_	0,42	0,30	0,24	0,20
LGB_45 B_/F_	0,50	0,34	0,28	0,20
LGB_55 B_/F_	0,60	0,42	0,34	0,25
LGBXH21 TN/WN	0,26	0,17	-	-
LGBXH27 TN/WN	0,26	0,17	-	-
LGBXH35 TN/WN	0,26	0,17	0,14	-

Table 3.7 Calculation factors x for Miniature guides

Type	x	
	Z0	Z1
LGM_07 B_	0,13	0,02
LGM_09 B_	0,18	0,03
LGM_12 B_	0,25	0,06
LGM_15 B_	0,30	0,10

Height tolerance in a longitudinal direction between two carriages

The values for the height tolerances in a longitudinal direction (Figure 3.17) of the carriages are calculated using the calculation factor y (Tables 3.8 and 3.9) and Formula [3.2].

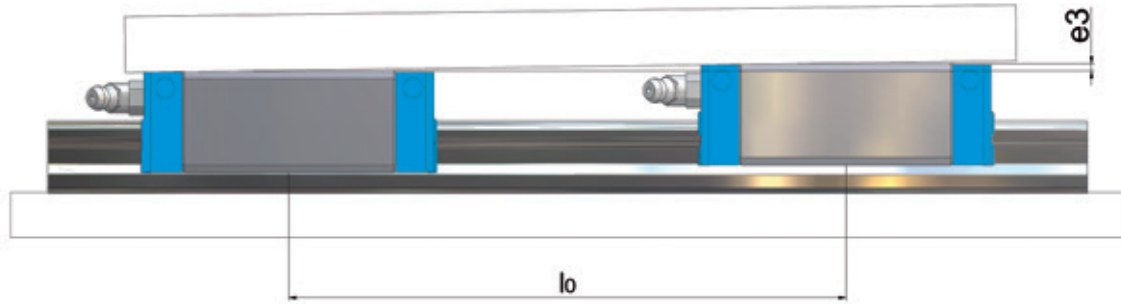

Figure 3.17 Height tolerance in longitudinal e_3

$$e_3 = l_0 * y \quad [3.2]$$

e_3 Height tolerance between two carriages [μm]
 l_0 Distance between the carriages [mm]
 y Calculation factors

Table 3.8 Calculation factors y for the Standard Linear Guides

Type		y			
		Z0	Z1	Z2	Z3
LGB_15	BS/FS	0,14	0,11	0,09	0,07
	BN/FN	0,12	0,10	0,08	0,06
	BL/FL	0,11	0,09	0,07	0,06
LGB_20	BS/FS	0,15	0,12	0,10	0,08
	BN/FN	0,13	0,11	0,09	0,07
	BL/FL	0,12	0,10	0,08	0,06
	BE/FE	0,10	0,09	0,07	0,06
LGB_25	BS/FS	0,17	0,14	0,12	0,09
	BN/FN	0,15	0,12	0,10	0,08
	BL/FL	0,14	0,11	0,09	0,07
	BE/FE	0,12	0,10	0,08	0,06
LGB_30	FS	0,21	0,17	0,14	0,11
	BN/FN	0,18	0,15	0,12	0,10
	BL/FL	0,16	0,13	0,11	0,09
	BE/FE	0,14	0,12	0,10	0,08
LGB_35	FS	0,29	0,24	0,20	0,15
	BN/FN	0,25	0,21	0,17	0,13
	BL/FL	0,23	0,19	0,15	0,12
	BE/FE	0,20	0,17	0,14	0,11
LGB_45	BN/FN	0,30	0,25	0,20	0,16
	BL/FL	0,27	0,22	0,18	0,14
	BE/FE	0,24	0,20	0,16	0,13
LGB_55	BN/FN	0,35	0,29	0,24	0,19
	BL/FL	0,32	0,26	0,21	0,17
	BE/FE	0,28	0,23	0,19	0,15
LGBXH21	TN/WN	0,12	0,10	0,08	-
LGBXH27	TN/WN	0,13	0,11	0,09	-
LGBXH35	TN/WN	0,15	0,12	0,10	-

Table 3.9 Calculation factors y for Miniature guides

Type		y	
		Z0	Z1
LGM_07	BN	0,07	0,04
LGM_09	BN/WN	0,10	0,08
	BL/WL	0,09	0,07
LGM_12	BN/WN	0,13	0,11
	BL/WL	0,12	0,10
LGM_15	BN/WN	0,17	0,14
	BL/WL	0,15	0,13

3.7 Fastening torques

The specific fastening torque strongly depends on the friction values. Different surfaces and lubrication conditions create a wide range of friction values. The mean friction coefficient for black-finished, nonlubricated screws is 0.14. The recommended fastening torques for fastening screws (Figure 3.18) of the Strength Classes 10.9 and 12.9 are provided in Table 3.10.

Table 3.10 Fastening torques for fastening screws (for $\mu=0,14$)

	Strength class 10.9			Strength class 12.9	
	Fastening torque [Nm]	Minimum screw-in depth steel [Nm]	Minimum screw-in depth aluminum [Nm]	Fastening torque [Nm]	Minimum screw-in depth steel [Nm]
M2	0,5	2,8	3,4	0,6	3,2
M2,5	1,0	3,6	4,2	1,2	4,0
M3	1,8	4,3	5,1	2,2	4,8
M4	4,4	5,6	6,5	5,1	6,1
M5	8,7	5,8	8,0	10,0	7,5
M6	15,0	8,0	9,5	18,0	8,8
M8	36,0	10,4	12,3	43,0	11,4
M10	72,0	12,8	15,1	84,0	14,1
M12	125,0	15,2	18,0	145,0	16,7
M14	200,0	17,5	21,0	235,0	19,6
M16	310,0	19,8	23,7	365,0	21,9

Screws of strength class 12.9 should always be used for high dynamics, overhead installations or installations without a locating edge.

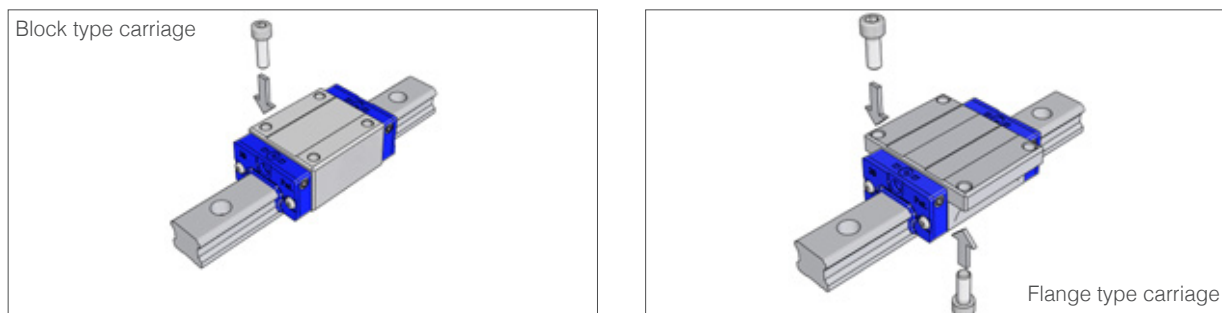

Figure 3.18 Mounting options of carriages

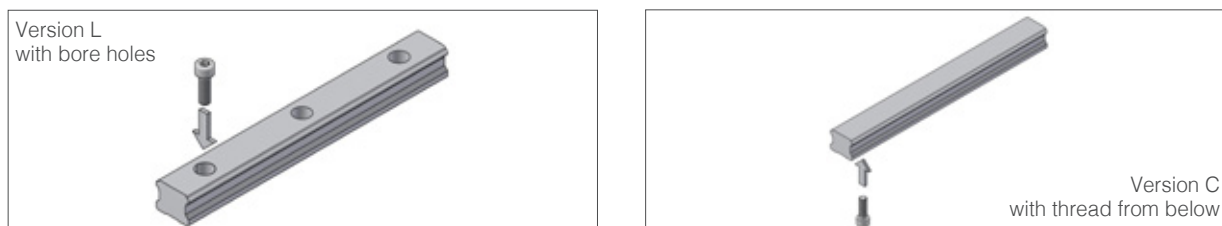

Figure 3.19 Mounting options of standard rails

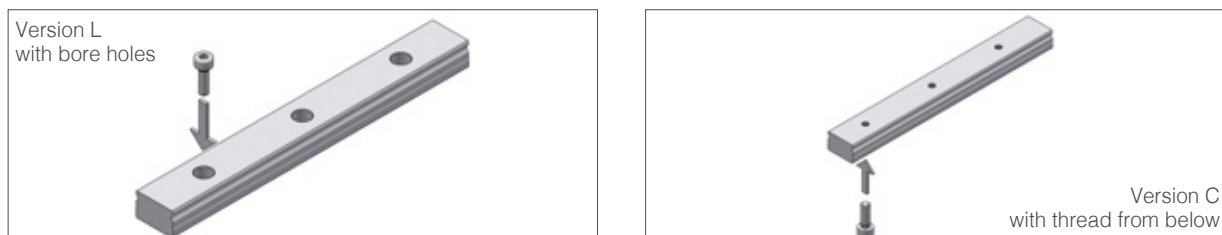

Figure 3.20 Mounting options of miniature rails

4 Lubrication

4.1. General information

Sufficient lubrication is essential for reliable function of the Linear Guide system. The lubrication intended to ensure a lubricating film (oil film) between the rolling elements and the raceways of the guiding elements to prevent wear and the premature fatigue of the components. In addition, the metallic surfaces are protected from corrosion. The lubricant film further facilitates jerk-free gliding of the seals over the surfaces and also reduces wear in these areas.

Insufficient lubrication not only increases wear but also significantly shortens the service life time.

The selection of the optimal lubricant has a significant effect on the function and service life time of the Linear Guide system. Appropriate lubrication for the environmental temperature and the specific requirements must be determined to ensure that the function of the system is not restricted and remains available for a prolonged period.

Examples of such environmental conditions and influencing factors are:

- High respectively low temperatures
- Condensed and splash water effects
- Radiation stress
- High vibration stress
- Use in vacuum and/or clean rooms
- Exposure to special media (e.g. fumes, acids, etc.)
- High accelerations and velocity
- Continuous, short stroke movements (< 2 x carriage length)
- Dirt and dust effects

4.2 Lubricants

Lubrication oil, low-viscosity or other greases can be selected for the lubrication of Linear Guide systems.

Function of the lubricant:

- Reduction of the friction
- Reduction of the start-up moment
- Protection against premature wear
- Corrosion protection
- Noise reduction

Attention!

Lubricants with solid additives such as graphite, PTFE or MoS₂ are not suitable for the lubrication of Linear Guide systems.

We provide a range of high-performance lubricants for different environmental conditions and influence factors. Information about the lubricant are contained in the Chapters 4.2.2 up to 4.2.4.

4.2.1 Anti-corrosion oils

Anti-corrosion oils are used to protect the Linear Guides against corrosion during storage and transport. Anti-corrosion oils are not suitable for lubricating Linear Guides during operation. Compatibility with the planned lubricant must always be checked before re-lubrication and initial operation.

SNR Linear Guides are delivered with the anti-corrosion oil “Contrakor Fluid H1”. “Contrakor Fluid H1” is compatible with our standard lubricant. Preservation may be omitted by agreement for special applications with special lubricants.

4.2.2 Lubrication oils

Oil lubrication is usually applied in central lubrication systems. The advantage of an automated, central oil lubrication is that of operator-independent, continuous lubricant supply to all lubrication points. Lubrication oils also conduct friction heat very well. This is balanced against a very high construction and installation effort for lubrication lines. Lubrication oil also leaks more often from the carriage and is thus lost to the system. To ensure that all raceways of a Linear Guide supplied with sufficient lubricant, it is necessary for oil lubrication to adapt the lubrication channels in the end plates to the mounting position. The installation positions are to be defined according to the information in Chapter 3.4. Appropriate lubrication oils for use in SNR Linear Guides are summarised in Table 4.1.

Table 4.1 Lubrication oils

Description	Oil type	Kinematic viscosity according to DIN51562 at 40°C [mm ² /s]	Density [mg/cm ³]	Properties	Application area
Klüberoil GEM 1-100N	Mineral oil	100	880	Good corrosion and wear protection	<ul style="list-style-type: none"> • General machine building
Klüberoil 4 UH1-68N	Polyalphaolefin	680	860	good ageing and wear protection, NSF H1 registered*	<ul style="list-style-type: none"> • Foodprocessing industry • Pharmaceutical industry

* This lubricant has been registered as an H1 product, i.e. it was developed for occasional, technically unavoidable contact with food. Experience has shown that the lubricant can also be used for appropriate applications in the pharmaceutical and cosmetic industry when the conditions in the product information are adhered to. However, no specific test results that might be required for applications in the pharmaceutical industry, e.g. bio-compatibility, are available. The systems manufacturer and operator should therefore perform appropriate risk analyses before applications in this area. Measures to exclude health risks and injuries have to be taken, where required. (Source: Klüber Lubrication)

4.2.3 Low-viscosity greases

The conditions that apply to the use of lubrication oils also apply to the use of low-viscosity greases.

However, it is not necessary to define the installation position, as low-viscosity greases do not run off easily, due to their viscosity. Appropriate low-viscosity greases for use in SNR Linear Guides are summarised in Table 4.2

Table 4.2 Low-viscosity greases

Description	Base oil / Type of soap	NLGI-class DIN51818	Worked penetration DIN ISO 2137 at 25°C [0,1 mm]	Basic oil viscosity DIN 51562 at 40°C [mm ² /s]	Density [g/cm ³]	Properties	Application area
Isoflex Topas NCA 5051	Synthetic hydrocarbon oil, special calcium soap	0/00	385...415	30	800	Low friction	<ul style="list-style-type: none"> • General machine building
Microlube GB 0	Mineral oil	0	355...385	400	900	Good wear Protection, Particularly pressure resistant	<ul style="list-style-type: none"> • General machine building • High loads • Short-stroke application • Vibrations
Klübersynth UH1 14-1600	Synthetic hydrocarbon oil, special Aluminum-complex soap	0/00	370...430	ca. 160	850	Good ageing and Wear protection, NSF H1 registered*	<ul style="list-style-type: none"> • Food processing industry • Pharmaceutical industry

* This lubricant has been registered as an H1 product, i.e. it was developed for occasional, technically unavoidable contact with food. Experience has shown that the lubricant can also be used for appropriate applications in the pharmaceutical and cosmetic industry when the conditions in the product information are adhered to. However, no specific test results that might be required for applications in the pharmaceutical industry, e.g. bio-compatibility, are available. The systems manufacturer and operator should therefore perform appropriate risk analyses before applications in this area. Measures to exclude health risks and injuries have to be taken, where required. (Source: Klüber Lubrication)

4.2.4 Lubrication greases

Most applications are based on Linear Guides with grease lubrication. The use of greases provides better noise reduction and also better emergency running properties and requires less constructive effort than lubrication oils and low-viscosity greases. Lithium soap greases with the Classification KP2-K according to DIN 51825 and NLGI Class 2 according to DIN 51818 with EP additives are to be used for applications under normal conditions. Suitable lubricants must be selected for specific applications under special environmental conditions. It must always be checked whether the different lubricants used are compatible with each other or with the preservation agent. Table 4.3 shows an overview of the lubricants used in SNR Linear Guides.

Table 4.3 Lubrication greases

Description	Base oil / Type of soap	NLGI- classe DIN51818	Worked penetration DIN ISO 2137 at 25°C [0,1mm]	Basic oil viscosity DIN 51562 at 40°C [mm²/s]	Density [mg/cm³]	Propertie	Application area
SNR LUB HEAVY DUTY	Mineral oil / Lithium with EP additives	2	295	ca. 115	890	Very high protection against wear and corrosion	<ul style="list-style-type: none"> • High temperature range • High loads
SNR LUB HIGH SPEED+	Esther, SHC / Lithium, Calcium	2	-	25	900	Very good adhesion properties, Very good water resistance	<ul style="list-style-type: none"> • High velocity
SNR LUB HIGH TEMP	semi-synthetic oil / Polyurea	2	265...295	160	900	High temperature resistance, Good corrosion protection, High oxidation resistance	<ul style="list-style-type: none"> • High temperature range
SNR LUB FOOD AL	Paraffinic mineral oil, PAO / Aluminum complex	2	265...295	195	920	Good corrosion protection, Very good adhesion properties, High water resistance, NSF H1 registered*	<ul style="list-style-type: none"> • Food processing industry
Microlube GL261	Mineral oil / special lithium-calcium soap	1	310...340	280	890	Good wearing protection, Particularly pressure-resistant, Additive against tribocorrosion	<ul style="list-style-type: none"> • High temperature range • High loads • Short-stroke application • Vibrations
Klübersynth BEM34-32	Synthetic hydrocarbon oil / special calcium soap	2	265...295	ca. 30	890	Particularly pressure-resistant, Good wearing protection, Good ageing resistance, Low starting torque	<ul style="list-style-type: none"> • Clean room application
Klübersynth UH1 14-151	Synthetic hydrocarbon oil / ester oil Aluminum complex soap	1	310...340	ca. 150	920	Good corrosion protection, Good ageing resistance, High water resistance, NSF H1 registered*	<ul style="list-style-type: none"> • Food processing industry • Pharmaceutical industry

* This lubricant has been registered as an H1 product, i.e. it was developed for occasional, technically unavoidable contact with food. Experience has shown that the lubricant can also be used for appropriate applications in the pharmaceutical and cosmetic industry when the conditions in the product information are adhered to. However, no specific test results that might be required for applications in the pharmaceutical industry, e.g. bio-compatibility, are available. The systems manufacturer and operator should therefore perform appropriate risk analyses before applications in this area. Measures to exclude health risks and injuries have to be taken, where required. (Source: Klüber Lubrication)

4.3. Lubrication methods

SNR Linear Guides can be supplied with lubricant by manual grease guns (Figure 4.1) or central lubrication systems (Figure 4.2). The carriages are re-lubricated through the installed grease nipple (Chapter 6.6.2) when manual grease guns (Chapter 6.6.4) are used.

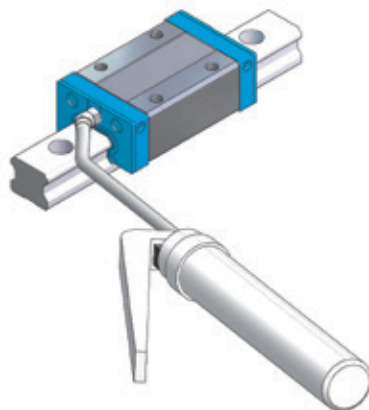

Figure 4.1 Lubrication with manual grease gun

Central lubrication systems can be manually operated or automatically controlled. Manual central lubrication systems have a pump that is operated with a manual lever and supplies all lubrication points with lubricant. Automated central lubrication systems ensure a regular supply of all lubrication points with the amount of lubricant required. These systems can also be implemented as oil-spray lubrication systems under special environmental conditions. Oil is nebulised by compressed air and transported to the lubrication points. Oil mist lubrication systems ensure continuous supply of the lubrication points with the minimum amount of lubricant required and optimal conduction of friction heat. The permanent overpressure in the system also prevents the penetration of foreign particles such as dust or cooling lubricant into the carriages.



Figure 4.2 Central lubrication systems

4.4 Lubricant volumes

Maintenance of Linear Guides may involve:

- Initial lubrication
- Lubrication during initial operation
- Re-lubrication

The respective minimum lubricant amounts are defined as a function of the type and design size of the Linear Guide. SNR Linear Guides are initially lubricated with lithium soap grease KP2-K according to DIN 51825 and NGLI Class 2 at the time of delivery. We recommend to lubricate the carriages again for the initial operation. Table 4.4 shows the minimum amounts of lubrication that have to be provided to SNR Linear Guides for initial lubrication and lubrication for initial operation.

Table 4.4 Minimum amounts of lubricant for initial lubrication and lubrication for initial operation

Size	Carriage	C Types			X Types		
		Grease lubrication [cm ³]	Low-viscosity grease lubrication [ml]	Oil lubrication [ml]	Grease lubrication [cm ³]	Low-viscosity grease lubrication [ml]	Oil lubrication [ml]
LGB_15	FS/BS	0,20		0,15	0,30		0,15
	BN/FN	0,30		0,20	0,40		0,20
	BL/FL	0,40		0,20	0,50		0,20
LGB_20	FS/BS	0,30		0,30	0,40		0,30
	BN/FN	0,50		0,40	0,60		0,40
	BL/FL	0,70		0,40	0,80		0,40
	BE/FE	0,90		0,50	1,00		0,50
LGB_25	FS/BS	0,70		0,40	0,80		0,40
	BN/FN	0,90		0,50	1,00		0,50
	BL/FL	1,90		0,60	2,00		0,60
	BE/FE	2,40		0,70	2,50		0,70
LGB_30	FS	1,90		0,70	2,00		0,70
	BN/FN	2,40		0,90	2,50		0,90
	BL/FL	2,90		1,00	3,00		1,00
	BE/FE	3,40		1,20	3,50		1,20
LGB_35	FS	2,90		0,90	3,00		0,90
	BN/FN	3,40		1,40	3,50		1,40
	BL/FL	3,90		1,50	4,00		1,50
	BE/FE	4,40		1,80	4,50		1,80
LGB_45	BN/FN	3,90		2,00	4,00		2,00
	BL/FL	4,90		2,30	5,00		2,30
	BE/FE	5,40		2,80	5,50		2,80
LGB_55	BN/FN	5,80		3,50	6,00		3,50
	BL/FL	7,80		4,50	8,00		4,50
	BE/FE	9,80		5,50	10,00		5,50
LGB_21	TN/WN	-		-	0,50		0,20
LGB_27	TN/WN	-		-	1,00		0,50
LGB_35	TN/WN	-		-	2,50		0,90
LGM_07	BN	-		-	0,01		-
LGM_09	BN	0,02		-	0,03		-
	BL	0,04		-	0,05		-
	WN	0,03		-	0,04		-
	WL	0,04		-	0,05		-
LGM_12	BN	0,04		-	0,05		-
	BL	0,06		-	0,08		-
	WN	0,04		-	0,05		-
	WL	0,08		-	0,10		-
LGM_15	BN	0,08		-	0,10		-
	BL	0,12		-	0,15		-
	WN	0,08		-	0,10		-
	WL	0,12		-	0,15		-

The demand for lubricant is lower during operation than the initial amount as delivered. In Table 4.5 are shown the minimum amounts of lubricant for re-lubrication.

Table 4.5 Minimum amounts of lubricant for re-lubrication

Size	Carriage	C Types			X Types		
		Grease lubrication [cm³]	Low-viscosity grease lubrication [ml]	Oil lubrication [ml]	Grease lubrication [cm³]	Low-viscosity grease lubrication [ml]	Oil lubrication [ml]
LGB_15	FS/BS	0,10	0,10		0,15	0,10	
	BN/FN	0,15	0,10		0,20	0,10	
	BL/FL	0,20	0,10		0,25	0,10	
LGB_20	FS/BS	0,15	0,10		0,20	0,10	
	BN/FN	0,25	0,20		0,30	0,20	
	BL/FL	0,35	0,20		0,40	0,20	
LGB_25	BE/FE	0,45	0,20		0,50	0,20	
	FS/BS	0,35	0,10		0,40	0,10	
	BN/FN	0,45	0,20		0,50	0,20	
LGB_30	BL/FL	0,95	0,20		1,00	0,20	
	BE/FE	1,20	0,30		1,25	0,30	
	FS	0,95	0,20		1,00	0,20	
LGB_35	BN/FN	1,20	0,20		1,25	0,20	
	BL/FL	1,45	0,30		1,50	0,30	
	BE/FE	1,70	0,30		1,75	0,30	
LGB_45	FS	1,45	0,20		1,50	0,20	
	BN/FN	1,70	0,30		1,75	0,30	
	BL/FL	1,95	0,30		2,00	0,30	
LGB_55	BE/FE	2,20	0,40		2,25	0,40	
	BN/FN	1,95	0,50		2,00	0,50	
	BL/FL	2,45	0,50		2,50	0,50	
LGB_21	BE/FE	2,70	0,60		2,75	0,60	
	BN/FN	2,90	0,60		3,00	0,60	
	BL/FL	3,90	0,60		4,00	0,60	
LGB_27	BE/FE	4,90	0,70		5,00	0,70	
LGB_27	TN/WN	-	-		0,25	0,10	
LGB_35	TN/WN	-	-		0,50	0,20	
LGM_07	TN/WN	-	-		1,25	0,30	
LGM_09	BN	-	-		0,01	-	
	BL	0,01	-		0,02	-	
	WN	0,02	-		0,03	-	
	WL	0,02	-		0,02	-	
LGM_12	WL	0,02	-		0,03	-	
	BN	0,02	-		0,04	-	
	BL	0,03	-		0,03	-	
	WN	0,02	-		0,03	-	
LGM_15	WL	0,04	-		0,05	-	
	BN	0,04	-		0,08	-	
	BL	0,06	-		0,05	-	
	WN	0,04	-		0,05	-	
	WL	0,06	-		0,08	-	

4.5 Lubrication intervals

Delivery condition

The SNR carriages of all series are already provided with initial lubrication at the time of delivery. The carriages should be lubricated one more time after mounting with the grease amount from Table 4.4 in 2-3 steps with intermediate movement over a longer stroke for the optimal grease distribution in the system.

The carriages also require initial lubrication before a prolonged shut-down and before re-operation.

The mixing compatibility of the lubricants must be checked when the lubricant make is to be changed during operation of a system.

Influence factors

The re-lubrication intervals are affected by several factors (Chapter 4.1). Load and pollution usually have the strongest effect. Accurate re-lubrication intervals for a specific system can only be determined after the actual operating conditions have been assessed for a sufficiently long period.

Lubrication interval for oil lubrication

The reference value for adjusting central oil lubrication systems is one lubrication pulse per carriage every 20 minutes, using the amount of lubricant specified in Table 4.5. Central lubrication systems with low-viscosity grease should be set to a lubrication interval of 60 minutes.

Lubrication interval for Linear Guides with grease lubrication

To determine the re-lubrication intervals, it is necessary to estimate the acting loads and environmental conditions as accurately as possible. Under these conditions, the expected re-lubrication intervals can be determined as guideline from the Diagrams in Figure 4.3 for conventional Linear Guides and Figure 4.4 for Linear Guides with ball chains.

Figure 4.3 Re-lubrication interval for conventional Linear Guides

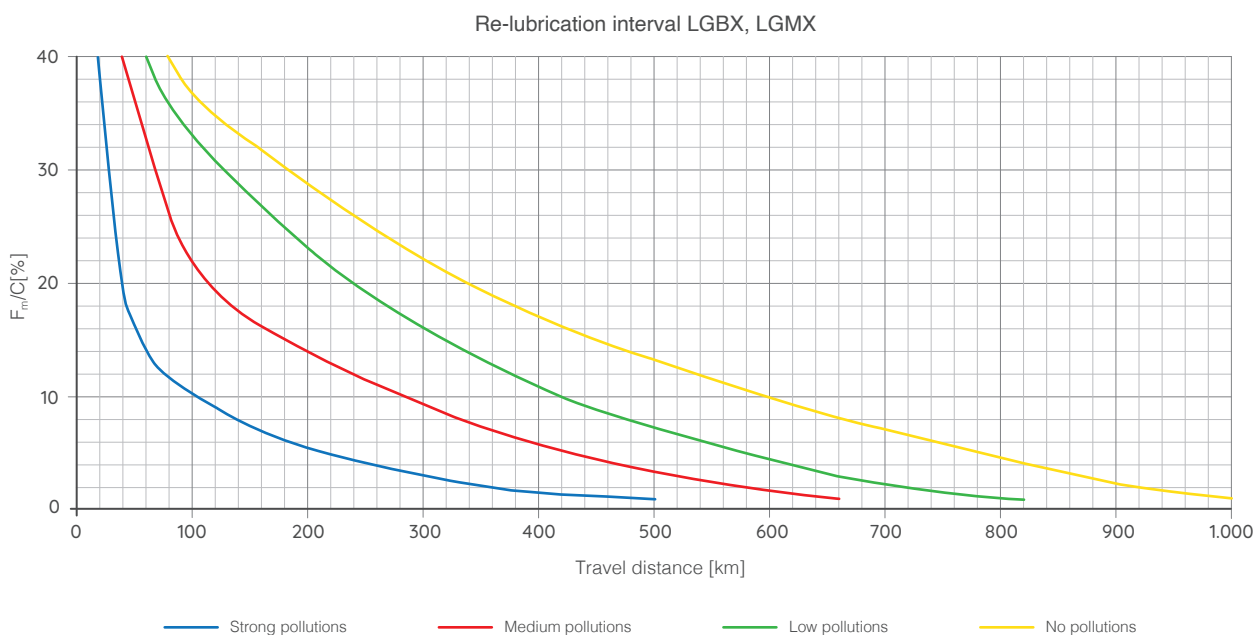
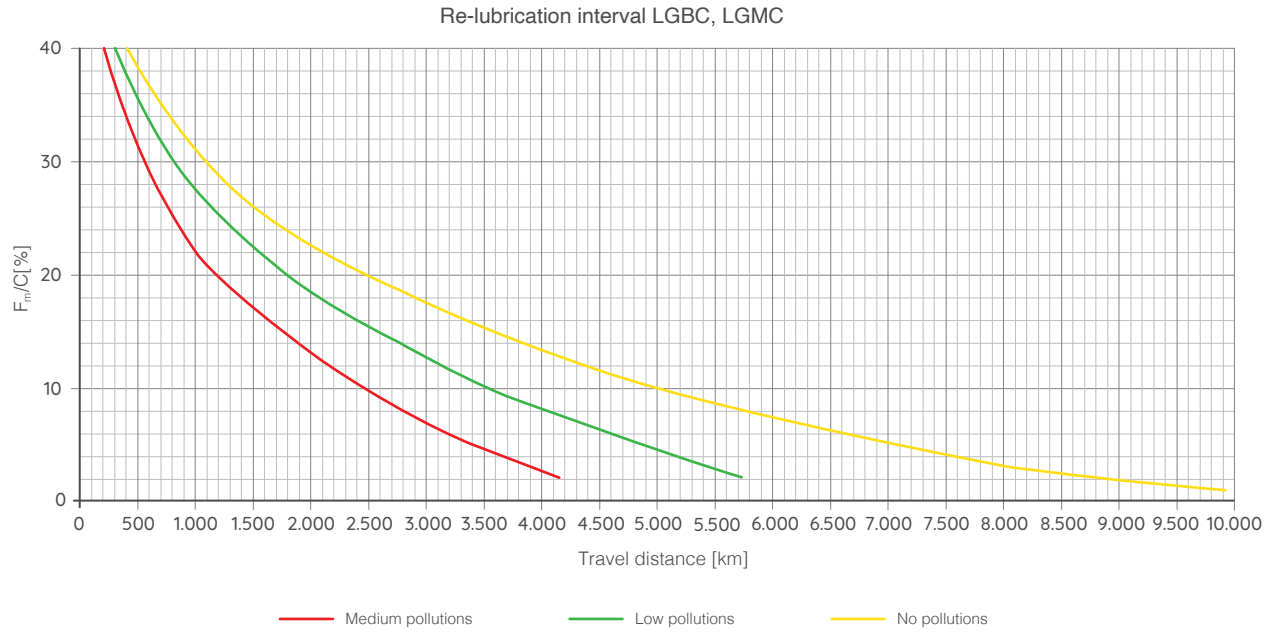

Figure 4.4 Re-lubrication interval for Linear Guides with ball chain



A precise determination of re-lubrication intervals can only be made after determination under real operating conditions and assessment over a sufficiently long period for a specific application.

If it is not possible to determine the acting loads and the environmental conditions exactly, re-lubrication intervals of 100 km for conventional Linear Guides and 500 km for Linear Guides with ball chains are considered as a guideline.

Independent of the determined re-lubrication interval, the carriages must be re-lubricated after the maximum service life of the lubricant has been reached which is specified by the manufacturer, but at the latest after two years due to grease aging.

Our application engineers will gladly help you to determine the maintenance intervals.

5 SNR Linear Guides

5.1 Overview

SNR Linear Guides are high-quality precision products. They combine customer-oriented product development and high quality requirements. They offer the customer a wide product range for various applications in all areas of industry.

The most important characteristics are:

SNR standard Linear Guides

- Arrangement of the raceways at a 45° angle which results in equal load ratings in all main directions
- Low system friction with a maximum friction coefficient, μ of 0.003 due to circular arc grooves
- High tolerance compensation and error compensation capability due to DF-arrangement of the race ways
- Multitude of lubrication connections can be mounted on all sides of the carriage
- All seals in two-lip versions for optimal protection of the carriage against liquid and solid foreign particles
- Wide range of sealing options for special applications
- Low-noise and long-term maintenance-free ball chain type carriages with long service life time
- Linear Guides with ball chain and conventional types on the same rail
- Dimensions according to DIN ISO 12090-1 and DIN ISO 12090-2.
- Velocity of up to 5 m/s
- Acceleration of up to 50 m/s²

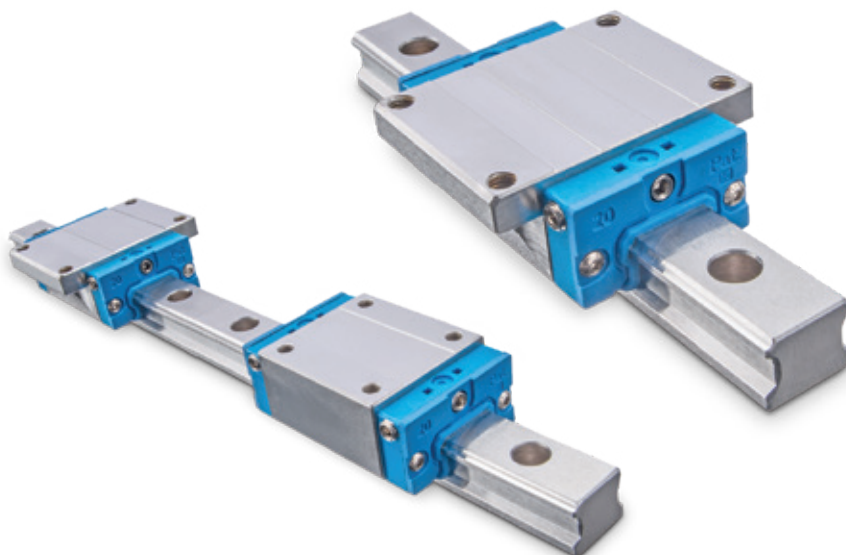

Wide SNR standard Linear Guides without ball chains

- Arrangement of the raceways at a 45° angle which results in equal load ratings in all main directions
- Wide version for high moment loads in Mx direction
- Velocity of up to 5 m/s
- Acceleration of up to 50 m/s²

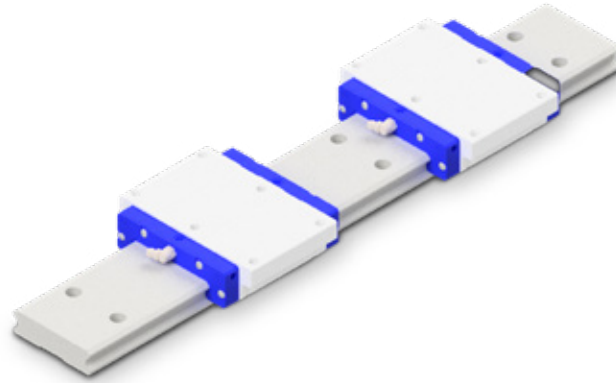

SNR miniature guides

- Compact design
- Profile rail and carriage made of corrosion-resistant material
- Available in narrow and wide rail versions
- With ball chain and in conventional type available



5.2 LGBCH_F

Linear Guide with ball chain, carriage in flange design, normal design height

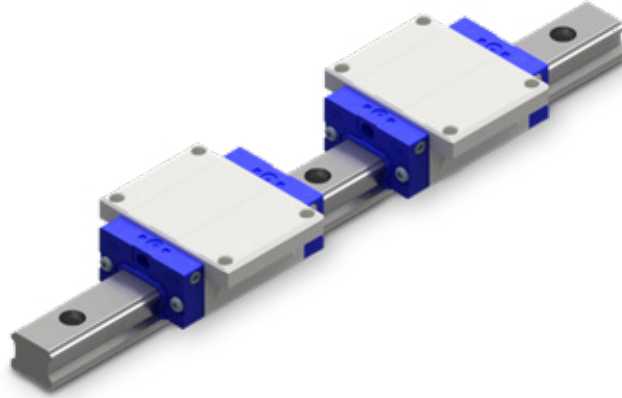

Example of type code

LGBCH 25 FN 2 SS L 02000 N Z1 - 2 - 0 -20.0 N*

		System mm					Carriage mm												
		H	W	W2	E	L	B	J	MQ	ih	I	L1	H2	T1	N	T2	L2	H3	Lx
LGBCH15	FN	24	47	16,0	3,4	58,6	38	30	M 5	4,4	7,5	40,2	M 3 x 0,5	5,5	2,5	4,5	4,20	M 3 x 0,5	3,0
LGBCH15	FL	24	47	16,0	3,4	66,1	38	30	M 5	4,4	7,5	47,7	M 3 x 0,5	5,5	2,5	4,5	4,20	M 3 x 0,5	3,0
LGBCH20	FN	30	63	21,5	4,5	70,1	53	40	M 6	5,4	9,0	48,5	M 6 x 1,0	7,1	12,3	6,3	4,25	M 6 x 1,0	3,8
LGBCH20	FL	30	63	21,5	4,5	82,9	53	40	M 6	5,4	9,0	61,3	M 6 x 1,0	7,1	12,3	6,3	4,25	M 6 x 1,0	3,8
LGBCH20	FE	30	63	21,5	4,5	98,1	53	40	M 6	5,4	9,0	76,5	M 6 x 1,0	7,1	12,3	6,3	4,25	M 6 x 1,0	3,8
LGBCH25	FN	36	70	23,5	5,8	79,2	57	45	M 8	6,8	10,1	57,5	M 6 x 1,0	10,2	12,2	9,4	4,65	M 6 x 1,0	5,0
LGBCH25	FL	36	70	23,5	5,8	93,9	57	45	M 8	6,8	10,1	72,2	M 6 x 1,0	10,2	12,2	9,4	4,65	M 6 x 1,0	5,0
LGBCH25	FE	36	70	23,5	5,8	108,6	57	45	M 8	6,8	10,1	86,9	M 6 x 1,0	10,2	12,2	9,4	4,65	M 6 x 1,0	5,0
LGBCH30	FS	42	90	31,0	7,0	64,2	72	--	M 10	8,6	12,0	37,2	M 6 x 1,0	10,0	11,7	5,5	6,00	M 6 x 1,0	5,0
LGBCH30	FN	42	90	31,0	7,0	94,8	72	52	M 10	8,6	12,0	67,8	M 6 x 1,0	10,0	11,7	5,5	6,00	M 6 x 1,0	5,0
LGBCH30	FL	42	90	31,0	7,0	105,0	72	52	M 10	8,6	12,0	78,0	M 6 x 1,0	10,0	11,7	5,5	6,00	M 6 x 1,0	5,0
LGBCH30	FE	42	90	31,0	7,0	130,5	72	52	M 10	8,6	12,0	103,5	M 6 x 1,0	10,0	11,7	5,5	6,00	M 6 x 1,0	5,0
LGBCH35	FS	48	100	33,0	7,5	75,5	82	--	M 10	8,6	14,0	44,5	M 6 x 1,0	11,5	11,5	10,5	7,25	M 6 x 1,0	5,0
LGBCH35	FN	48	100	33,0	7,5	111,5	82	62	M 10	8,6	14,0	80,5	M 6 x 1,0	11,5	11,5	10,5	7,25	M 6 x 1,0	5,0
LGBCH35	FL	48	100	33,0	7,5	123,5	82	62	M 10	8,6	14,0	92,5	M 6 x 1,0	11,5	11,5	10,5	7,25	M 6 x 1,0	5,0
LGBCH35	FE	48	100	33,0	7,5	153,5	82	62	M 10	8,6	14,0	122,5	M 6 x 1,0	11,5	11,5	10,5	7,25	M 6 x 1,0	5,0
LGBCH45	FN	60	120	37,5	8,9	129,0	100	80	M 12	10,6	16,0	94,0	M 8 x 1,25	14,4	10,8	14,5	8,00	M 8 x 1,25	7,5
LGBCH45	FL	60	120	37,5	8,9	145,0	100	80	M 12	10,6	16,0	110,0	M 8 x 1,25	14,4	10,8	14,5	8,00	M 8 x 1,25	7,5
LGBCH45	FE	60	120	37,5	8,9	174,0	100	80	M 12	10,6	16,0	139,0	M 8 x 1,25	14,4	10,8	14,5	8,00	M 8 x 1,25	7,5
LGBCH55	FN	70	140	43,5	12,7	155,0	116	95	M 14	12,6	19,0	116,0	M 8 x 1,25	14,0	10,8	14,5	10,00	M 8 x 1,25	7,5
LGBCH55	FL	70	140	43,5	12,7	193,0	116	95	M 14	12,6	19,0	154,0	M 8 x 1,25	14,0	10,8	14,5	10,00	M 8 x 1,25	7,5
LGBCH55	FE	70	140	43,5	12,7	210,0	116	95	M 14	12,6	19,0	171,0	M 8 x 1,25	14,0	10,8	14,5	10,00	M 8 x 1,25	7,5

*Explanation to type code in Chapter 8

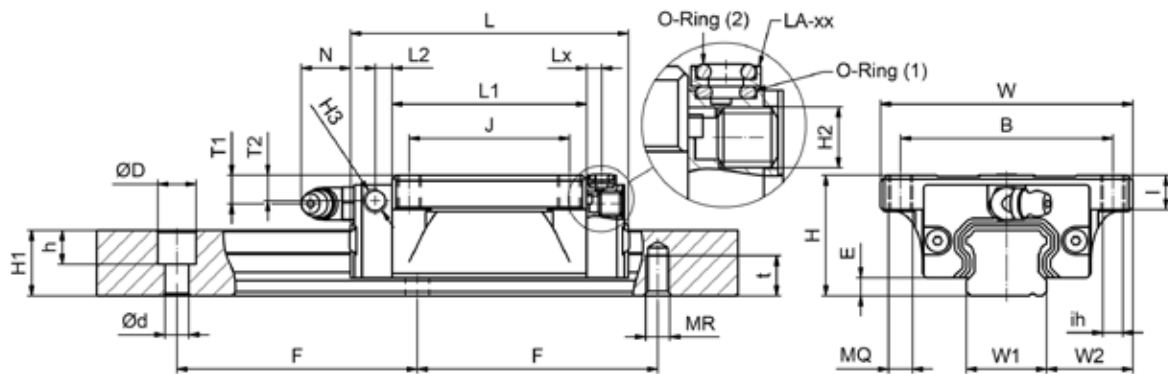
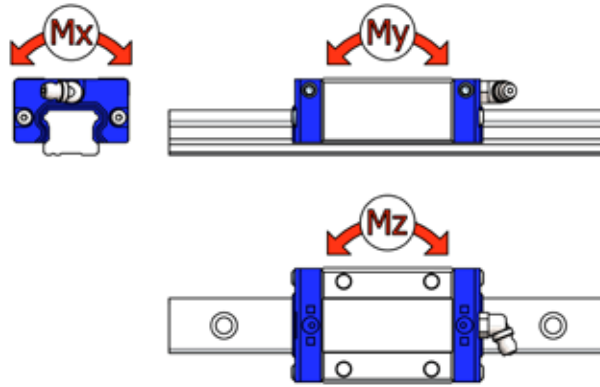

W1	H1	F	Rail [mm]					Load rating					Mass		
			d	D	h	Version L	Version C	kN		kNm			kg	kg/ m	
						MR	t	C	C0	MX	MY	MZ	Carriage	Rail	
15	13	60	4,5	7,5	5,5	M 5	8,0	11,67	19,90	0,137	0,120	0,120	0,21	1,28	LGBCH15 FN
15	13	60	4,5	7,5	5,5	M 5	8,0	14,12	24,05	0,166	0,171	0,171	0,23	1,28	LGBCH15 FL
20	16,3	60	6,0	9,5	8,7	M 6	10,0	17,98	30,96	0,289	0,224	0,224	0,40	2,15	LGBCH20 FN
20	16,3	60	6,0	9,5	8,7	M 6	10,0	23,30	40,11	0,376	0,366	0,366	0,46	2,15	LGBCH20 FL
20	16,3	60	6,0	9,5	8,7	M 6	10,0	27,85	49,61	0,464	0,565	0,565	0,61	2,15	LGBCH20 FE
23	19,2	60	7,0	11,0	9,2	M 6	12,0	25,25	41,73	0,447	0,358	0,358	0,57	2,88	LGBCH25 FN
23	19,2	60	7,0	11,0	9,2	M 6	12,0	32,44	53,63	0,576	0,577	0,577	0,72	2,88	LGBCH25 FL
23	19,2	60	7,0	11,0	9,2	M 6	12,0	36,58	64,30	0,691	0,833	0,833	0,89	2,88	LGBCH25 FE
28	22,8	80	9,0	14,0	12,2	M 8	15,0	18,50	27,51	0,356	0,153	0,153	0,80	4,45	LGBCH30 FS
28	22,8	80	9,0	14,0	12,2	M 8	15,0	37,33	55,50	0,719	0,560	0,560	1,10	4,45	LGBCH30 FN
28	22,8	80	9,0	14,0	12,2	M 8	15,0	48,35	71,88	0,931	0,836	0,836	1,34	4,45	LGBCH30 FL
28	22,8	80	9,0	14,0	12,2	M 8	15,0	53,83	88,18	1,142	1,361	1,361	1,66	4,45	LGBCH30 FE
34	26,0	80	9,0	14,0	12,2	M 8	17,0	26,72	41,43	0,655	0,275	0,275	1,00	6,25	LGBCH35 FS
34	26,0	80	9,0	14,0	12,2	M 8	17,0	53,31	82,66	1,307	0,991	0,991	1,50	6,25	LGBCH35 FN
34	26,0	80	9,0	14,0	12,2	M 8	17,0	66,61	103,29	1,633	1,424	1,424	1,90	6,25	LGBCH35 FL
34	26,0	80	9,0	14,0	12,2	M 8	17,0	73,29	127,68	2,020	2,330	2,330	2,54	6,25	LGBCH35 FE
45	31,1	105	14,0	20,0	17,0	M 12	20,0	73,14	111,30	2,353	1,559	1,559	2,27	9,60	LGBCH45 FN
45	31,1	105	14,0	20,0	17,0	M 12	20,0	86,99	132,39	2,798	2,170	2,170	2,68	9,60	LGBCH45 FL
45	31,1	105	14,0	20,0	17,0	M 12	20,0	100,52	166,87	3,527	3,455	3,455	3,42	9,60	LGBCH45 FE
53	38,0	120	16,0	23,0	20,0	M 14	24,0	88,26	136,62	3,385	2,361	2,361	3,44	13,80	LGBCH55 FN
53	38,0	120	16,0	23,0	20,0	M 14	24,0	119,10	183,14	4,538	4,202	4,202	4,63	13,80	LGBCH55 FL
53	38,0	120	16,0	23,0	20,0	M 14	24,0	161,43	259,71	6,430	6,617	6,617	5,16	13,80	LGBCH55 FE

5.3 LGBCS_F

Linear Guide with ball chain, carriage in flange design, flat design height

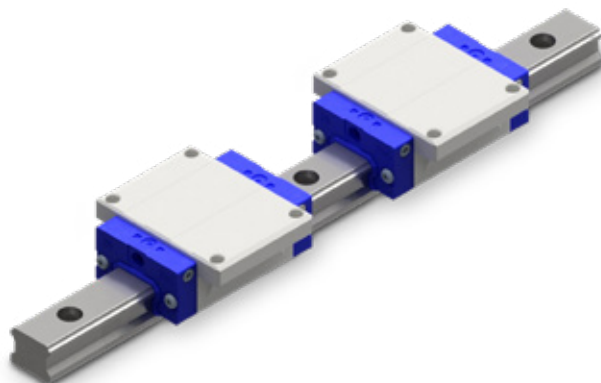

Example of type code

LGBCS 25 FN 2 SS L 02000 N Z1 - 2 - 0 -20.0 N*

			System mm					Carriage mm												
			H	W	W2	E	L	B	J	MQ	ih	l	L1	H2	T1	N	T2	L2	H3	Lx
LGBCS15	FS	FS	24	52	18,5	3,4	40,6	41	--	M 5	4,4	7,5	22,2	M 3 x 0,5	5,5	2,5	4,5	4,20	M 3 x 0,5	3,0
LGBCS15	FN	FN	24	52	18,5	3,4	58,6	41	26	M 5	4,4	7,5	40,2	M 3 x 0,5	5,5	2,5	4,5	4,20	M 3 x 0,5	3,0
LGBCS20	FS	FS	28	59	19,5	4,5	49,1	49	--	M 6	5,4	7,0	27,5	M 6 x 1,0	5,1	12,3	4,3	4,25	M 6 x 1,0	3,8
LGBCS20	FN	FN	28	59	19,5	4,5	70,1	49	32	M 6	5,4	7,0	48,5	M 6 x 1,0	5,1	12,3	4,3	4,25	M 6 x 1,0	3,8
LGBCS25	FS	FS	33	73	25,0	5,8	54,0	60	--	M 8	6,8	7,1	32,3	M 6 x 1,0	7,2	12,2	6,4	4,65	M 6 x 1,0	5,0
LGBCS25	FN	FN	33	73	25,0	5,8	79,2	60	35	M 8	6,8	7,1	57,5	M 6 x 1,0	7,2	12,2	6,4	4,65	M 6 x 1,0	5,0

*Explanation to type code in Chapter 8

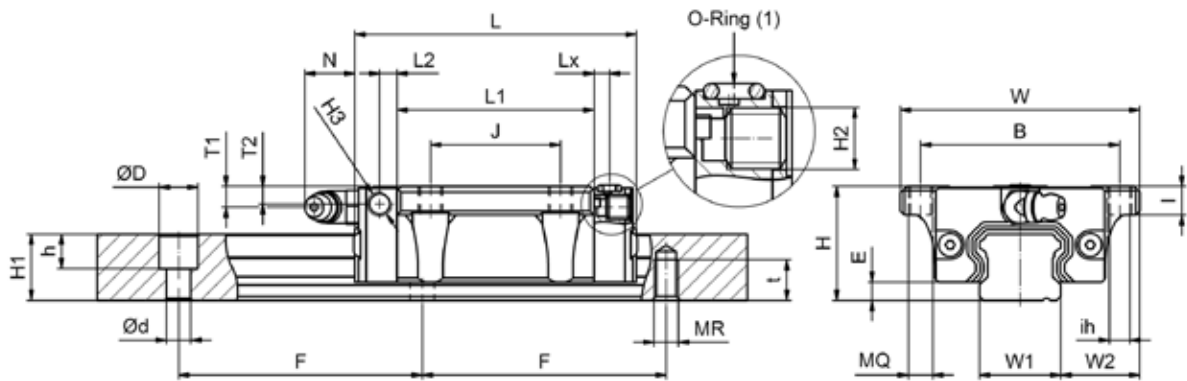
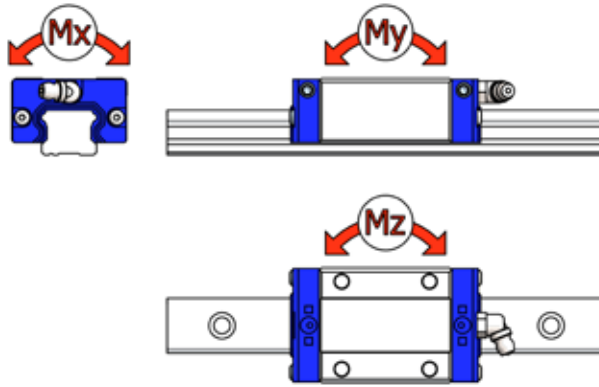

W1	H1	F	Rail [mm]					Load rating						Mass		
			d	Version L		Version C		kN		kNm			Carriage	Rail		
				D	h	MR	t	C	C0	MX	MY	MZ				
15	13	60	4,5	7,5	5,5	M 5	8,0	5,81	9,90	0,069	0,032	0,032	0,12	1,28	LGBCS15	FS
15	13	60	4,5	7,5	5,5	M 5	8,0	11,67	19,90	0,137	0,120	0,120	0,19	1,28	LGBCS15	FN
20	16,3	60	6,0	9,5	8,7	M 6	10,0	9,25	15,93	0,148	0,066	0,066	0,18	2,15	LGBCS20	FS
20	16,3	60	6,0	9,5	8,7	M 6	10,0	17,98	30,96	0,289	0,224	0,224	0,31	2,15	LGBCS20	FN
23	19,2	60	7,0	11,0	9,2	M 6	12,0	12,87	21,34	0,230	0,103	0,103	0,33	2,88	LGBCS25	FS
23	19,2	60	7,0	11,0	9,2	M 6	12,0	25,25	41,73	0,447	0,358	0,358	0,50	2,88	LGBCS25	FN

5.4 LGBCH_B / LGBCX_B

Linear guide with ball chain, carriages in block design, in normal /medium design height

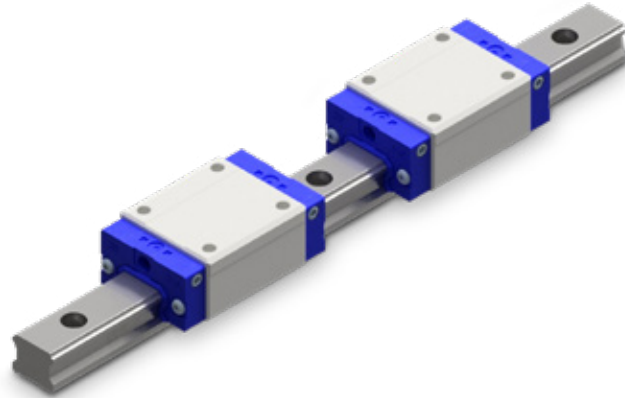

Example of type code

LGBCH 25 BN 2 SS L 02000 N Z1 - 2 - 0 -20.0 N*

	System mm						Carriage mm										
	H	W	W2	E	L	B	J	MQ	I	L1	H2	T1	N	T2	L2	H3	Lx
LGBCH15 BN	28	34	9,5	3,4	58,6	26	26	M 4	6,0	40,2	M 3 x 0,5	9,5	2,5	8,5	4,20	M 3 x 0,5	3,0
LGBCH20 BN	30	44	12,0	4,5	70,1	32	36	M 5	6,5	48,5	M 6 x 1,0	7,1	12,3	6,3	4,25	M 6 x 1,0	3,8
LGBCH20 BL	30	44	12,0	4,5	82,9	32	36	M 5	6,5	61,3	M 6 x 1,0	7,1	12,3	6,3	4,25	M 6 x 1,0	3,8
LGBCH20 BE	30	44	12,0	4,5	98,1	32	50	M 5	6,5	76,5	M 6 x 1,0	7,1	12,3	6,3	4,25	M 6 x 1,0	3,8
LGBCX25 BN	36	48	12,5	5,8	79,2	35	35	M 6	9,0	57,5	M 6 x 1,0	10,2	12,2	9,4	4,65	M 6 x 1,0	5,0
LGBCX25 BL	36	48	12,5	5,8	93,9	35	35	M 6	9,0	72,2	M 6 x 1,0	10,2	12,2	9,4	4,65	M 6 x 1,0	5,0
LGBCX25 BE	36	48	12,5	5,8	108,6	35	50	M 6	9,0	86,9	M 6 x 1,0	10,2	12,2	9,4	4,65	M 6 x 1,0	5,0
LGBCH25 BN	40	48	12,5	5,8	79,2	35	35	M 6	9,0	57,5	M 6 x 1,0	14,2	12,2	13,4	4,65	M 6 x 1,0	5,0
LGBCH25 BL	40	48	12,5	5,8	93,9	35	35	M 6	9,0	72,2	M 6 x 1,0	14,2	12,2	13,4	4,65	M 6 x 1,0	5,0
LGBCH25 BE	40	48	12,5	5,8	108,6	35	50	M 6	9,0	86,9	M 6 x 1,0	14,2	12,2	13,4	4,65	M 6 x 1,0	5,0
LGBCH30 BN	45	60	16,0	7,0	94,8	40	40	M 8	12,0	67,8	M 6 x 1,0	13,0	11,7	8,5	6,00	M 6 x 1,0	5,0
LGBCH30 BL	45	60	16,0	7,0	105,0	40	40	M 8	12,0	78,0	M 6 x 1,0	13,0	11,7	8,5	6,00	M 6 x 1,0	5,0
LGBCH30 BE	45	60	16,0	7,0	130,5	40	60	M 8	12,0	103,5	M 6 x 1,0	13,0	11,7	8,5	6,00	M 6 x 1,0	5,0
LGBCH35 BN	55	70	18,0	7,5	111,5	50	50	M 8	12,0	80,5	M 6 x 1,0	18,5	11,5	13,5	7,25	M 6 x 1,0	5,0
LGBCH35 BL	55	70	18,0	7,5	123,5	50	50	M 8	12,0	92,5	M 6 x 1,0	18,5	11,5	13,5	7,25	M 6 x 1,0	5,0
LGBCH35 BE	55	70	18,0	7,5	153,5	50	72	M 8	12,0	122,5	M 6 x 1,0	18,5	11,5	13,5	7,25	M 6 x 1,0	5,0
LGBCH45 BN	70	86	20,5	8,9	129,0	60	60	M 10	18,0	94,0	M 8 x 1,25	24,5	10,8	24,5	8,00	M 8 x 1,25	7,5
LGBCH45 BL	70	86	20,5	8,9	145,0	60	60	M 10	18,0	110,8	M 8 x 1,25	24,5	10,8	24,5	8,00	M 8 x 1,25	7,5
LGBCH45 BE	70	86	20,5	8,9	174,0	60	80	M 10	18,0	139,0	M 8 x 1,25	24,5	10,8	24,5	8,00	M 8 x 1,25	7,5
LGBCH55 BN	80	100	23,5	12,7	155,0	75	75	M 12	22,0	116,0	M 8 x 1,25	24,0	10,8	24,5	10,80	M 8 x 1,25	7,5
LGBCH55 BL	80	100	23,5	12,7	193,0	75	75	M 12	22,0	154,0	M 8 x 1,25	24,0	10,8	24,5	10,80	M 8 x 1,25	7,5
LGBCH55 BE	80	100	23,5	12,7	210,8	75	95	M 12	22,0	171,0	M 8 x 1,25	24,0	10,8	24,5	10,80	M 8 x 1,25	7,5

*Explanation to type code in Chapter 8

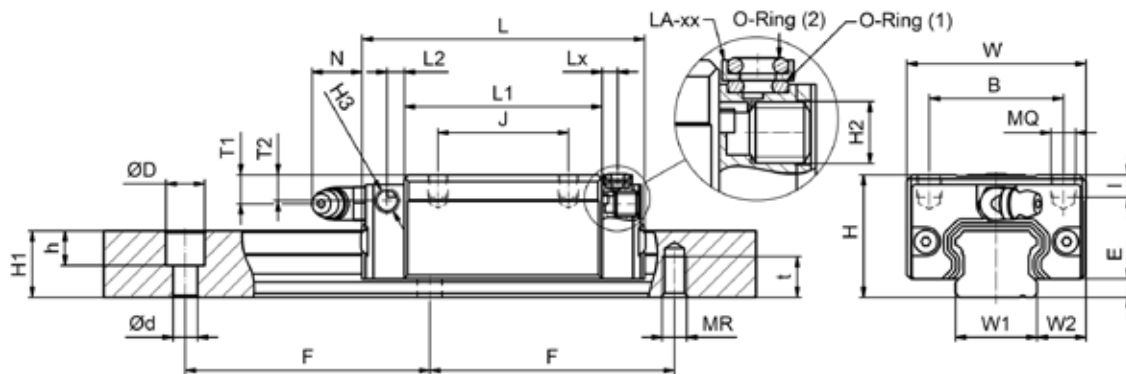
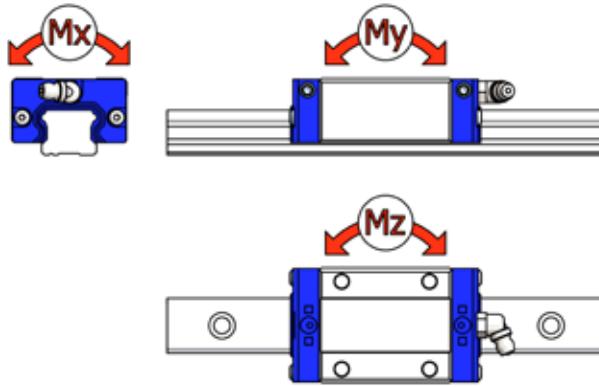

W1	H1	F	Rail [mm]					Load rating					Mass		Code
			Version L			Version C		kN		kNm			kg	kg/ m	
			d	D	h	MR	t	C	C0	MX	MY	MZ	Carriage	Rail	
15	13,0	60	4,5	7,5	5,5	M 5	8,0	11,67	19,90	0,137	0,120	0,120	0,19	1,28	LGBCH15 BN
20	16,3	60	6,0	9,5	8,7	M 6	10,0	17,98	30,96	0,289	0,224	0,224	0,31	2,15	LGBCH20 BN
20	16,3	60	6,0	9,5	8,7	M 6	10,0	23,30	40,11	0,376	0,366	0,366	0,36	2,15	LGBCH20 BL
20	16,3	60	6,0	9,5	8,7	M 6	10,0	27,85	49,61	0,464	0,565	0,565	0,47	2,15	LGBCH20 BE
23	19,2	60	7,0	11,0	9,2	M 6	12,0	25,25	41,73	0,447	0,358	0,358	0,40	2,88	LGBCX25 BN
23	19,2	60	7,0	11,0	9,2	M 6	12,0	32,44	53,63	0,576	0,577	0,577	0,54	2,88	LGBCX25 BL
23	19,2	60	7,0	11,0	9,2	M 6	12,0	36,58	64,30	0,691	0,833	0,833	0,67	2,88	LGBCX25 BE
23	19,2	60	7,0	11,0	9,2	M 6	12,0	25,25	41,73	0,447	0,358	0,358	0,45	2,88	LGBCH25 BN
23	19,2	60	7,0	11,0	9,2	M 6	12,0	32,44	53,63	0,576	0,577	0,577	0,66	2,88	LGBCH25 BL
23	19,2	60	7,0	11,0	9,2	M 6	12,0	36,58	64,30	0,691	0,833	0,833	0,80	2,88	LGBCH25 BE
28	22,8	80	9,0	14,0	12,2	M 8	15,0	37,33	55,50	0,719	0,560	0,560	0,91	4,45	LGBCH30 BN
28	22,8	80	9,0	14,0	12,2	M 8	15,0	48,35	71,88	0,931	0,836	0,836	1,04	4,45	LGBCH30 BL
28	22,8	80	9,0	14,0	12,2	M 8	15,0	53,83	88,18	1,142	1,361	1,361	1,36	4,45	LGBCH30 BE
34	26,0	80	9,0	14,0	12,2	M 8	17,0	53,31	82,66	1,307	0,991	0,991	1,50	6,25	LGBCH35 BN
34	26,0	80	9,0	14,0	12,2	M 8	17,0	66,61	103,29	1,633	1,424	1,424	1,80	6,25	LGBCH35 BL
34	26,0	80	9,0	14,0	12,2	M 8	17,0	73,29	127,68	2,020	2,330	2,330	2,34	6,25	LGBCH35 BE
45	31,1	105	14,0	20,0	17,0	M 12	20,0	73,14	111,30	2,353	1,559	1,559	2,28	9,60	LGBCH45 BN
45	31,1	105	14,0	20,0	17,0	M 12	20,0	86,99	132,39	2,798	2,170	2,170	2,67	9,60	LGBCH45 BL
45	31,1	105	14,0	20,0	17,0	M 12	20,0	100,52	166,87	3,527	3,455	3,455	3,35	9,60	LGBCH45 BE
53	38,0	120	16,0	23,0	20,0	M 14	24,0	88,26	136,62	3,385	2,361	2,361	3,42	13,80	LGBCH55 BN
53	38,0	120	16,0	23,0	20,0	M 14	24,0	119,10	183,14	4,538	4,202	4,202	4,57	13,80	LGBCH55 BL
53	38,0	120	16,0	23,0	20,0	M 14	24,0	161,43	259,71	6,430	6,617	6,617	5,08	13,80	LGBCH55 BE

5.5 LGBCS_B

Linear Guide with ball chain, carriages in block design, flat design height

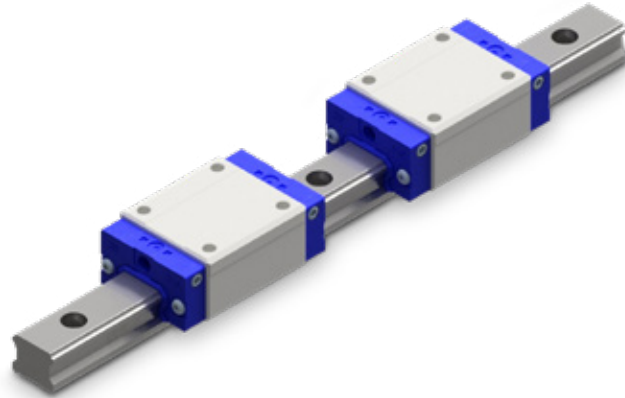

Example of type code

LGBCS 25 BN 2 SS L 02000 N Z1 - 2 - 0 -20.0 N*

	System mm						Carriage mm										
	H	W	W2	E	L	B	J	MQ	I	L1	H2	T1	N	T2	L2	H3	Lx
LGBCS15 BS	24	34	9,5	3,4	40,6	26	--	M 4	4,8	22,2	M 3 x 0,5	5,5	2,5	4,5	4,20	M 3 x 0,5	3,0
LGBCS15 BN	24	34	9,5	3,4	58,6	26	26	M 4	4,8	40,2	M 3 x 0,5	5,5	2,5	4,5	4,20	M 3 x 0,5	3,0
LGBCS15 BL	24	34	9,5	3,4	66,1	26	26	M 4	4,8	47,7	M 3 x 0,5	5,5	2,5	4,5	4,20	M 3 x 0,5	3,0
LGBCS20 BS	28	42	11,0	4,5	49,1	32	--	M 5	5,5	27,5	M 6 x 1,0	5,1	15,6	4,3	4,25	M 6 x 1,0	3,8
LGBCS20 BN	28	42	11,0	4,5	70,1	32	32	M 5	5,5	48,5	M 6 x 1,0	5,1	15,6	4,3	4,25	M 6 x 1,0	3,8
LGBCS25 BS	33	48	12,5	5,8	54,0	35	--	M 6	6,8	32,3	M 6 x 1,0	7,2	12,2	6,4	4,65	M 6 x 1,0	5,0
LGBCS25 BN	33	48	12,5	5,8	79,2	35	35	M 6	6,8	57,5	M 6 x 1,0	7,2	12,2	6,4	4,65	M 6 x 1,0	5,0
LGBCS30 BS	42	60	16,0	7,0	64,2	40	--	M 8	10,0	37,2	M 6 x 1,0	10,0	11,7	5,5	6,00	M 6 x 1,0	5,0
LGBCS30 BN	42	60	16,0	7,0	94,8	40	40	M 8	10,0	67,8	M 6 x 1,0	10,0	11,7	5,5	6,00	M 6 x 1,0	5,0
LGBCS30 BL	42	60	16,0	7,0	105,0	40	40	M 8	10,0	78,0	M 6 x 1,0	10,0	11,7	5,5	6,00	M 6 x 1,0	5,0
LGBCS30 BE	42	60	16,0	7,0	130,5	40	60	M 8	10,0	103,5	M 6 x 1,0	10,0	11,7	5,5	6,00	M 6 x 1,0	5,0
LGBCS35 BS	48	70	18,0	7,5	75,5	50	--	M 8	10,0	44,5	M 6 x 1,0	11,5	11,5	10,5	7,25	M 6 x 1,0	5,0
LGBCS35 BN	48	70	18,0	7,5	111,5	50	50	M 8	10,0	80,5	M 6 x 1,0	11,5	11,5	10,5	7,25	M 6 x 1,0	5,0
LGBCS35 BL	48	70	18,0	7,5	123,5	50	50	M 8	10,0	92,5	M 6 x 1,0	11,5	11,5	10,5	7,25	M 6 x 1,0	5,0
LGBCS35 BE	48	70	18,0	7,5	153,5	50	72	M 8	10,0	122,5	M 6 x 1,0	11,5	11,5	10,5	7,25	M 6 x 1,0	5,0
LGBCS45 BN	60	86	20,5	8,9	129,0	60	60	M 10	15,5	94,0	M 8 x 1,25	14,4	11,8	14,5	8,00	M 8 x 1,25	7,5
LGBCS45 BL	60	86	20,5	8,9	145,0	60	60	M 10	15,5	110,0	M 8 x 1,25	14,4	11,8	14,5	8,00	M 8 x 1,25	7,5
LGBCS45 BE	60	86	20,5	8,9	174,0	60	80	M 10	15,5	139,0	M 8 x 1,25	14,4	11,8	14,5	8,00	M 8 x 1,25	7,5
LGBCS55 BN	70	100	23,5	12,7	155,0	75	75	M 12	18,0	116,0	M 8 x 1,25	14,0	11,8	14,5	10,00	M 8 x 1,25	7,5
LGBCS55 BL	70	100	23,5	12,7	193,0	75	75	M 12	18,0	154,0	M 8 x 1,25	14,0	11,8	14,5	10,00	M 8 x 1,25	7,5
LGBCS55 BE	70	100	23,5	12,7	210,0	75	95	M 12	18,0	171,0	M 8 x 1,25	14,0	11,8	14,5	10,00	M 8 x 1,25	7,5

*Explanation to type code in Chapter 8

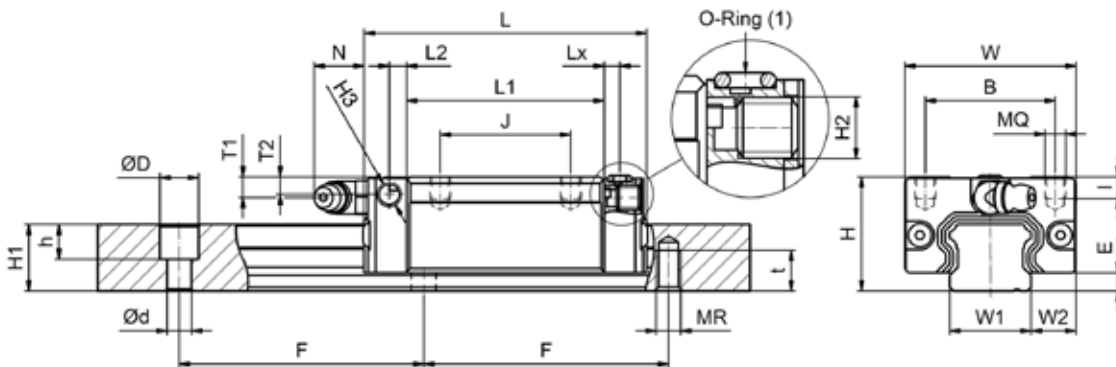
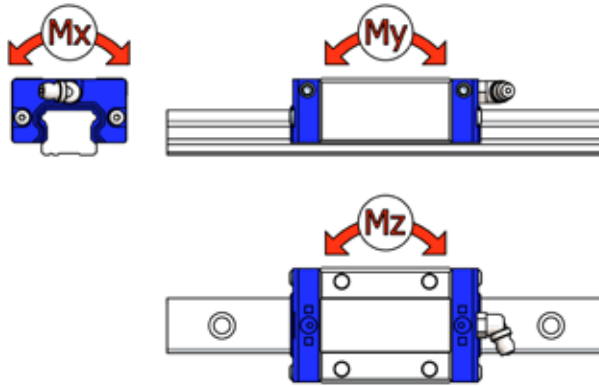

W1	H1	F	Rail [mm]					Load rating						Mass		
			Version L			Version C		kN		kNm			kg	kg/ m		
			d	D	h	MR	t	C	C0	MX	MY	MZ	Carriage	Rail		
15	13,0	60	4,5	7,5	5,5	M 5	8,0	5,81	9,90	0,069	0,032	0,032	0,10	1,28	LGBCS15 BS	
15	13,0	60	4,5	7,5	5,5	M 5	8,0	11,67	19,90	0,137	0,120	0,120	0,17	1,28	LGBCS15 BN	
15	13,0	60	4,5	7,5	5,5	M 5	8,0	14,12	24,05	0,166	0,171	0,171	0,18	1,28	LGBCS15 BL	
20	16,3	60	6,0	9,5	8,7	M 6	10,0	9,25	15,93	0,148	0,066	0,066	0,17	2,15	LGBCS20 BS	
20	16,3	60	6,0	9,5	8,7	M 6	10,0	17,98	30,96	0,289	0,224	0,224	0,26	2,15	LGBCS20 BN	
23	19,2	60	7,0	11,0	9,2	M 6	12,0	12,87	21,34	0,230	0,103	0,103	0,21	2,88	LGBCS25 BS	
23	19,2	60	7,0	11,0	9,2	M 6	12,0	25,25	41,73	0,447	0,358	0,358	0,38	2,88	LGBCS25 BN	
28	22,8	80	9,0	14,0	12,2	M 8	15,0	18,50	27,51	0,356	0,153	0,153	0,50	4,45	LGBCS30 BS	
28	22,8	80	9,0	14,0	12,2	M 8	15,0	37,33	55,50	0,719	0,560	0,560	0,80	4,45	LGBCS30 BN	
28	22,8	80	9,0	14,0	12,2	M 8	15,0	48,35	71,88	0,931	0,836	0,836	0,94	4,45	LGBCS30 BL	
28	22,8	80	9,0	14,0	12,2	M 8	15,0	53,83	88,18	1,142	1,361	1,361	1,16	4,45	LGBCS30 BE	
34	26,0	80	9,0	14,0	12,2	M 8	17,0	26,72	41,43	0,655	0,275	0,275	0,80	6,25	LGBCS35 BS	
34	26,0	80	9,0	14,0	12,2	M 8	17,0	53,31	82,66	1,307	0,991	0,991	1,20	6,25	LGBCS35 BN	
34	26,0	80	9,0	14,0	12,2	M 8	17,0	66,61	103,29	1,633	1,424	1,424	1,40	6,25	LGBCS35 BL	
34	26,0	80	9,0	14,0	12,2	M 8	17,0	73,29	127,68	2,020	2,330	2,330	1,84	6,25	LGBCS35 BE	
45	31,1	105	14,0	20,0	17,0	M 12	20,0	73,14	111,30	2,353	1,559	1,559	1,64	9,60	LGBCS45 BN	
45	31,1	105	14,0	20,0	17,0	M 12	20,0	86,99	132,39	2,798	2,170	2,170	1,93	9,60	LGBCS45 BL	
45	31,1	105	14,0	20,0	17,0	M 12	20,0	100,52	166,87	3,527	3,455	3,455	2,42	9,60	LGBCS45 BE	
53	38,0	120	16,0	23,0	20,0	M 14	24,0	88,26	136,62	3,385	2,361	2,361	2,67	13,80	LGBCS55 BN	
53	38,0	120	16,0	23,0	20,0	M 14	24,0	119,10	183,14	4,538	4,202	4,202	3,57	13,80	LGBCS55 BL	
53	38,0	120	16,0	23,0	20,0	M 14	24,0	161,43	259,71	6,430	6,617	6,617	3,97	13,80	LGBCS55 BE	

5.6 LGBXH_F

Linear Guide without ball chain, carriages in flange design normal design height

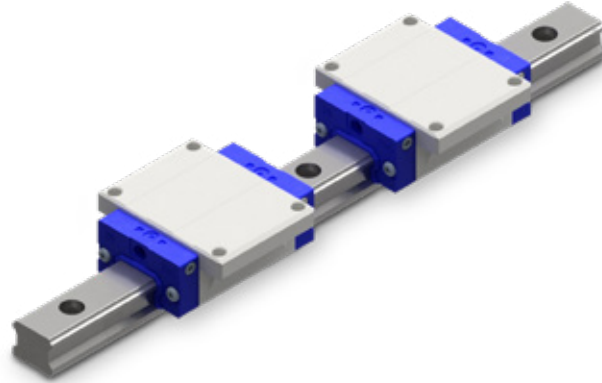

Example of type code

LGBXH 25 FN 2 SS L 02000 N Z1 - 2 - 0 -20.0 N*

		System mm					Carriage mm												
		H	W	W2	E	L	B	J	MQ	ih	I	L1	H2	T1	N	T2	L2	H3	Lx
LGBXH15	FN	24	47	16,0	3,4	58,6	38	30	M 5	4,4	7,5	40,2	M 3 x 0,5	5,5	2,5	4,5	4,20	M 3 x 0,5	3,0
LGBXH15	FL	24	47	16,0	3,4	66,1	38	30	M 5	4,4	7,5	47,7	M 3 x 0,5	5,5	2,5	4,5	4,20	M 3 x 0,5	3,0
LGBXH20	FN	30	63	21,5	4,5	70,1	53	40	M 6	5,4	9,0	48,5	M 6 x 1,0	7,1	12,3	6,3	4,25	M 6 x 1,0	3,8
LGBXH20	FL	30	63	21,5	4,5	82,9	53	40	M 6	5,4	9,0	61,3	M 6 x 1,0	7,1	12,3	6,3	4,25	M 6 x 1,0	3,8
LGBXH20	FE	30	63	21,5	4,5	98,1	53	40	M 6	5,4	9,0	76,5	M 6 x 1,0	7,1	12,3	6,3	4,25	M 6 x 1,0	3,8
LGBXH25	FN	36	70	23,5	5,8	79,2	57	45	M 8	6,8	10,1	57,5	M 6 x 1,0	10,2	12,2	9,4	4,65	M 6 x 1,0	5,0
LGBXH25	FL	36	70	23,5	5,8	93,9	57	45	M 8	6,8	10,1	72,2	M 6 x 1,0	10,2	12,2	9,4	4,65	M 6 x 1,0	5,0
LGBXH25	FE	36	70	23,5	5,8	108,6	57	45	M 8	6,8	10,1	86,9	M 6 x 1,0	10,2	12,2	9,4	4,65	M 6 x 1,0	5,0
LGBXH30	FS	42	90	31,0	7,0	64,2	72	--	M 10	8,6	12,0	37,2	M 6 x 1,0	10,0	11,7	5,5	6,00	M 6 x 1,0	5,0
LGBXH30	FN	42	90	31,0	7,0	94,8	72	52	M 10	8,6	12,0	67,8	M 6 x 1,0	10,0	11,7	5,5	6,00	M 6 x 1,0	5,0
LGBXH30	FL	42	90	31,0	7,0	105,0	72	52	M 10	8,6	12,0	78,0	M 6 x 1,0	10,0	11,7	5,5	6,00	M 6 x 1,0	5,0
LGBXH30	FE	42	90	31,0	7,0	130,5	72	52	M 10	8,6	12,0	103,5	M 6 x 1,0	10,0	11,7	5,5	6,00	M 6 x 1,0	5,0
LGBXH35	FS	48	100	33,0	7,5	75,5	82	--	M 10	8,6	14,0	44,5	M 6 x 1,0	11,5	11,5	10,5	7,25	M 6 x 1,0	5,0
LGBXH35	FN	48	100	33,0	7,5	111,5	82	62	M 10	8,6	14,0	80,5	M 6 x 1,0	11,5	11,5	10,5	7,25	M 6 x 1,0	5,0
LGBXH35	FL	48	100	33,0	7,5	123,5	82	62	M 10	8,6	14,0	92,5	M 6 x 1,0	11,5	11,5	10,5	7,25	M 6 x 1,0	5,0
LGBXH35	FE	48	100	33,0	7,5	153,5	82	62	M 10	8,6	14,0	122,5	M 6 x 1,0	11,5	11,5	10,5	7,25	M 6 x 1,0	5,0
LGBXH45	FN	60	120	37,5	8,9	129,0	100	80	M 12	10,6	16,0	94,0	M 8 x 1,25	14,4	10,8	14,5	8,00	M 8 x 1,25	7,5
LGBXH45	FL	60	120	37,5	8,9	145,0	100	80	M 12	10,6	16,0	110,0	M 8 x 1,25	14,4	10,8	14,5	8,00	M 8 x 1,25	7,5
LGBXH45	FE	60	120	37,5	8,9	174,0	100	80	M 12	10,6	16,0	139,0	M 8 x 1,25	14,4	10,8	14,5	8,00	M 8 x 1,25	7,5
LGBXH55	FN	70	140	43,5	12,7	155,0	116	95	M 14	12,6	19,0	116,0	M 8 x 1,25	14,0	10,8	14,5	10,00	M 8 x 1,25	7,5
LGBXH55	FL	70	140	43,5	12,7	193,0	116	95	M 14	12,6	19,0	154,0	M 8 x 1,25	14,0	10,8	14,5	10,00	M 8 x 1,25	7,5
LGBXH55	FE	70	140	43,5	12,7	210,0	116	95	M 14	12,6	19,0	171,0	M 8 x 1,25	14,0	10,8	14,5	10,00	M 8 x 1,25	7,5

*Explanation to type code in Chapter 8

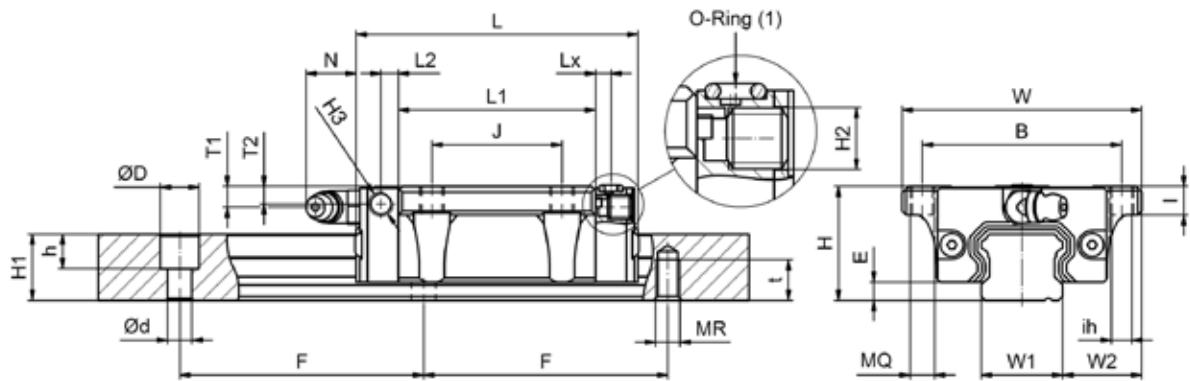
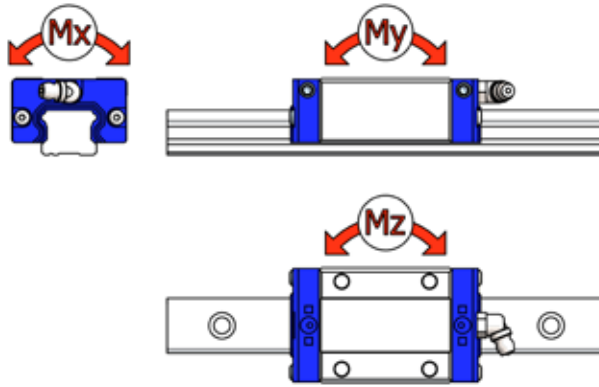

W1	H1	F	Rail [mm]					Load rating					Mass		LGBXH	FN
			d	D	h	MR	t	C	C0	MX	MY	MZ	kg	kg/ m		
			Version L			Version C							Carriage	Rail		
15	13	60	4,5	7,5	5,5	M 5	8,0	9,46	19,90	0,137	0,120	0,120	0,21	1,28	LGBXH15	FN
15	13	60	4,5	7,5	5,5	M 5	8,0	11,39	24,05	0,166	0,171	0,171	0,23	1,28	LGBXH15	FL
20	16,3	60	6,0	9,5	8,7	M 6	10,0	14,56	30,96	0,289	0,224	0,224	0,40	2,15	LGBXH20	FN
20	16,3	60	6,0	9,5	8,7	M 6	10,0	18,88	40,11	0,376	0,366	0,366	0,46	2,15	LGBXH20	FL
20	16,3	60	6,0	9,5	8,7	M 6	10,0	22,45	49,61	0,464	0,565	0,565	0,61	2,15	LGBXH20	FE
23	19,2	60	7,0	11,0	9,2	M 6	12,0	20,44	41,73	0,447	0,358	0,358	0,57	2,88	LGBXH25	FN
23	19,2	60	7,0	11,0	9,2	M 6	12,0	26,28	53,63	0,576	0,577	0,577	0,72	2,88	LGBXH25	FL
23	19,2	60	7,0	11,0	9,2	M 6	12,0	29,63	64,30	0,691	0,833	0,833	0,89	2,88	LGBXH25	FE
28	22,8	80	9,0	14,0	12,2	M 8	15,0	14,99	27,51	0,356	0,153	0,153	0,80	4,45	LGBXH30	FS
28	22,8	80	9,0	14,0	12,2	M 8	15,0	30,24	55,50	0,719	0,560	0,560	1,10	4,45	LGBXH30	FN
28	22,8	80	9,0	14,0	12,2	M 8	15,0	39,16	71,88	0,931	0,836	0,836	1,34	4,45	LGBXH30	FL
28	22,8	80	9,0	14,0	12,2	M 8	15,0	43,60	88,18	1,142	1,361	1,361	1,66	4,45	LGBXH30	FE
34	26,0	80	9,0	14,0	12,2	M 8	17,0	21,64	41,43	0,655	0,275	0,275	1,00	6,25	LGBXH35	FS
34	26,0	80	9,0	14,0	12,2	M 8	17,0	44,19	82,66	1,307	0,991	0,991	1,50	6,25	LGBXH35	FN
34	26,0	80	9,0	14,0	12,2	M 8	17,0	53,96	103,29	1,633	1,424	1,424	1,90	6,25	LGBXH35	FL
34	26,0	80	9,0	14,0	12,2	M 8	17,0	59,37	127,68	2,020	2,330	2,330	2,54	6,25	LGBXH35	FE
45	31,1	105	14,0	20,0	17,0	M 12	20,0	59,25	111,30	2,353	1,559	1,559	2,27	9,60	LGBXH45	FN
45	31,1	105	14,0	20,0	17,0	M 12	20,0	70,47	132,39	2,798	2,170	2,170	2,68	9,60	LGBXH45	FL
45	31,1	105	14,0	20,0	17,0	M 12	20,0	81,42	166,87	3,527	3,455	3,455	3,42	9,60	LGBXH45	FE
53	38,0	120	16,0	23,0	20,0	M 14	24,0	71,49	136,62	3,385	2,361	2,361	3,44	13,80	LGBXH55	FN
53	38,0	120	16,0	23,0	20,0	M 14	24,0	96,46	183,14	4,538	4,202	4,202	4,63	13,80	LGBXH55	FL
53	38,0	120	16,0	23,0	20,0	M 14	24,0	130,76	259,71	6,430	6,617	6,617	5,16	13,80	LGBXH55	FE

5.7 LGBXS_F

Linear Guide without ball chain, carriage in flange design, flat design height

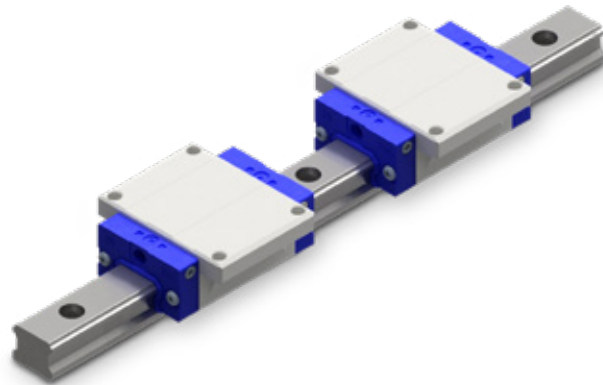

Example of type code

LGBXS 25 FN 2 SS L 02000 N Z1 - 2 - 0 - 20.0 N*

		System mm					Carriage mm												
		H	W	W2	E	L	B	J	MQ	ih	I	L1	H2	T1	N	T2	L2	H3	Lx
LGBXS15	FS	24	52	18,5	3,4	40,6	41	--	M 5	4,4	7,5	22,2	M 3 x 0,5	5,5	2,5	4,5	4,20	M 3 x 0,5	3,0
LGBXS15	FN	24	52	18,5	3,4	58,6	41	26	M 5	4,4	7,5	40,2	M 3 x 0,5	5,5	2,5	4,5	4,20	M 3 x 0,5	3,0
LGBXS20	FS	28	59	19,5	4,5	49,1	49	--	M 6	5,4	7,0	27,5	M 6 x 1,0	5,1	12,3	4,3	4,25	M 6 x 1,0	3,8
LGBXS20	FN	28	59	19,5	4,5	70,1	49	32	M 6	5,4	7,0	48,5	M 6 x 1,0	5,1	12,3	4,3	4,25	M 6 x 1,0	3,8
LGBXS25	FS	33	73	25,0	5,8	54,0	60	--	M 8	6,8	7,1	32,3	M 6 x 1,0	7,2	12,2	6,4	4,65	M 6 x 1,0	5,0
LGBXS25	FN	33	73	25,0	5,8	79,2	60	35	M 8	6,8	7,1	57,5	M 6 x 1,0	7,2	12,2	6,4	4,65	M 6 x 1,0	5,0

*Explanation to type code in Chapter 8

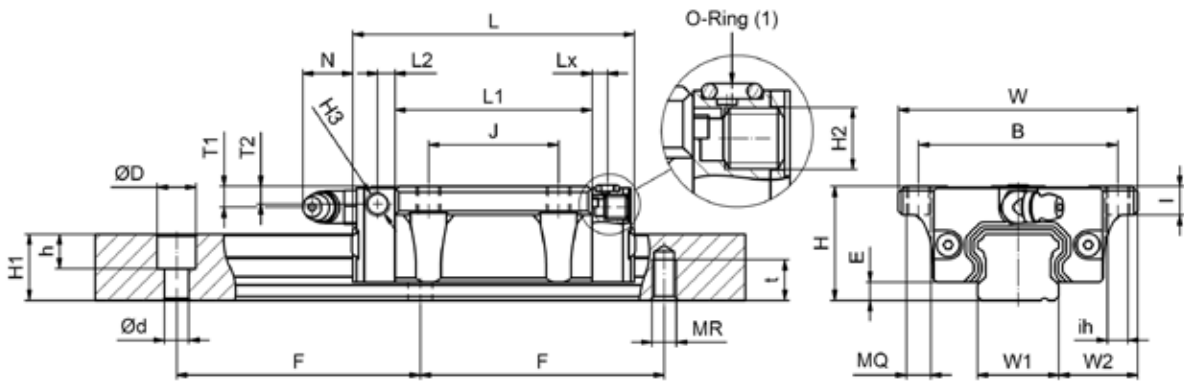
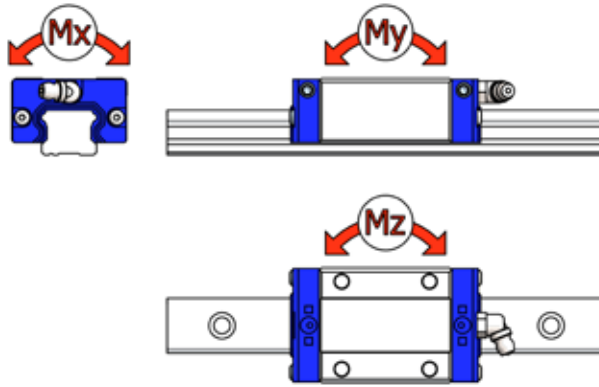

W1	H1	F	Rail [mm]					Load rating					Mass		Carriage	Rail	FS	FN
			d	D	h	MR	t	kN		kNm			kg	kg/ m				
			Version L			Version C		C	C0	MX	MY	MZ						
15	13	60	4,5	7,5	5,5	M 5	8,0	4,7	9,90	0,069	0,032	0,032	0,12	1,28	LGBXS15			
15	13	60	4,5	7,5	5,5	M 5	8,0	9,46	19,90	0,137	0,120	0,120	0,19	1,28	LGBXS15			
20	16,3	60	6,0	9,5	8,7	M 6	10,0	7,49	15,93	0,148	0,066	0,066	0,18	2,15	LGBXS20			
20	16,3	60	6,0	9,5	8,7	M 6	10,0	14,56	30,96	0,289	0,224	0,224	0,31	2,15	LGBXS20			
23	19,2	60	7,0	11,0	9,2	M 6	12,0	10,45	21,34	0,230	0,103	0,103	0,33	2,88	LGBXS25			
23	19,2	60	7,0	11,0	9,2	M 6	12,0	20,44	41,73	0,447	0,358	0,358	0,50	2,88	LGBXS25			

5.8 LGBXH_B / LGBXX_B

Linear Guide without ball chain, carriages in block design, normal / medium design height

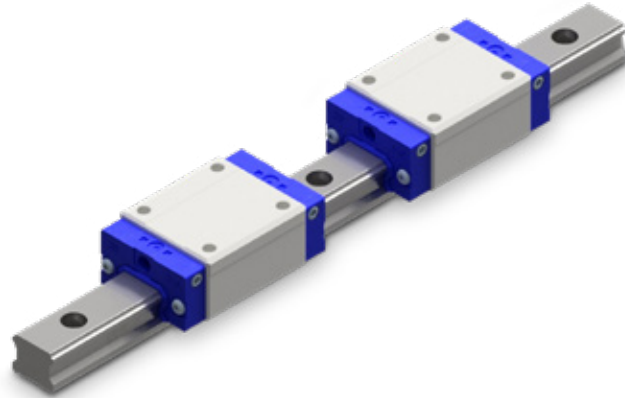

Example of type code

LGBXH 25 BN 2 SS L 02000 N Z1 - 2 - 0 -20.0 N*

	System mm					Carriage mm												
	H	W	W2	E	L	B	J	MQ	I	L1	H2	T1	N	T2	L2	H3	Lx	
LGBXH15	BN	28	34	9,5	3,4	58,6	26	26	M 4	6,0	40,2	M 3 x 0,5	9,5	2,5	8,5	4,20	M 3 x 0,5	3,0
LGBXH20	BN	30	44	12,0	4,5	70,1	32	36	M 5	6,5	48,5	M 6 x 1,0	7,1	12,3	6,3	4,25	M 6 x 1,0	3,8
LGBXH20	BL	30	44	12,0	4,5	82,9	32	36	M 5	6,5	61,3	M 6 x 1,0	7,1	12,3	6,3	4,25	M 6 x 1,0	3,8
LGBXH20	BE	30	44	12,0	4,5	98,13	32	50	M 5	6,5	76,5	M 6 x 1,0	7,1	12,3	6,3	4,25	M 6 x 1,0	3,8
LGBXX25	BN	36	48	12,5	5,8	79,2	35	35	M 6	9,0	57,5	M 6 x 1,0	10,2	12,2	9,4	4,65	M 6 x 1,0	5,0
LGBXX25	BL	36	48	12,5	5,8	93,9	35	35	M 6	9,0	72,2	M 6 x 1,0	10,2	12,2	9,4	4,65	M 6 x 1,0	5,0
LGBXX25	BE	36	48	12,5	5,8	108,6	35	50	M 6	9,0	86,9	M 6 x 1,0	10,2	12,2	9,4	4,65	M 6 x 1,0	5,0
LGBXH25	BN	40	48	12,5	5,8	79,2	35	35	M 6	9,0	57,5	M 6 x 1,0	14,2	12,2	13,4	4,65	M 6 x 1,0	5,0
LGBXH25	BL	40	48	12,5	5,8	93,9	35	35	M 6	9,0	72,2	M 6 x 1,0	14,2	12,2	13,4	4,65	M 6 x 1,0	5,0
LGBXH25	BE	40	48	12,5	5,8	108,6	35	50	M 6	9,0	86,9	M 6 x 1,0	14,2	12,2	13,4	4,65	M 6 x 1,0	5,0
LGBXH30	BN	45	60	16,0	7,0	94,8	40	40	M 8	12,0	67,8	M 6 x 1,0	13,0	11,7	8,5	6,00	M 6 x 1,0	5,0
LGBXH30	BL	45	60	16,0	7,0	105,0	40	40	M 8	12,0	78,0	M 6 x 1,0	13,0	11,7	8,5	6,00	M 6 x 1,0	5,0
LGBXH30	BE	45	60	16,0	7,0	130,5	40	60	M 8	12,0	103,5	M 6 x 1,0	13,0	11,7	8,5	6,00	M 6 x 1,0	5,0
LGBXH35	BN	55	70	18,0	7,5	111,5	50	50	M 8	12,0	80,5	M 6 x 1,0	18,5	11,5	13,5	7,25	M 6 x 1,0	5,0
LGBXH35	BL	55	70	18,0	7,5	123,5	50	50	M 8	12,0	92,5	M 6 x 1,0	18,5	11,5	13,5	7,25	M 6 x 1,0	5,0
LGBXH35	BE	55	70	18,0	7,5	153,5	50	72	M 8	12,0	122,5	M 6 x 1,0	18,5	11,5	13,5	7,25	M 6 x 1,0	5,0
LGBXH45	BN	70	86	20,5	8,9	129,0	60	60	M 10	18,0	94,0	M 8 x 1,25	24,5	10,8	24,5	8,00	M 8 x 1,25	7,5
LGBXH45	BL	70	86	20,5	8,9	145,0	60	60	M 10	18,0	110,0	M 8 x 1,25	24,5	10,8	24,5	8,00	M 8 x 1,25	7,5
LGBXH45	BE	70	86	20,5	8,9	174,0	60	80	M 10	18,0	139,0	M 8 x 1,25	24,5	10,8	24,5	8,00	M 8 x 1,25	7,5
LGBXH55	BN	80	100	23,5	12,7	155,0	75	75	M 12	22,0	116,0	M 8 x 1,25	24,0	10,8	24,5	10,00	M 8 x 1,25	7,5
LGBXH55	BL	80	100	23,5	12,7	193,0	75	75	M 12	22,0	154,0	M 8 x 1,25	24,0	10,8	24,5	10,00	M 8 x 1,25	7,5
LGBXH55	BE	80	100	23,5	12,7	210,0	75	95	M 12	22,0	171,0	M 8 x 1,25	24,0	10,8	24,5	10,00	M 8 x 1,25	7,5

*Explanation to type code in Chapter 8

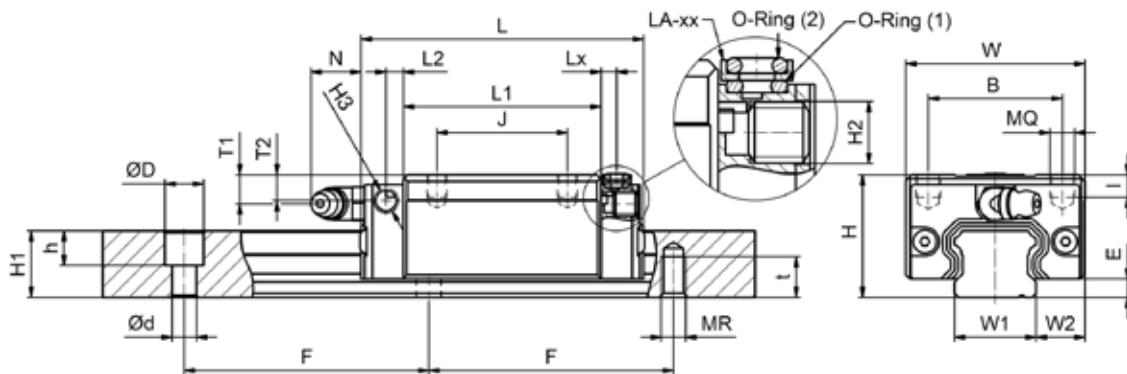
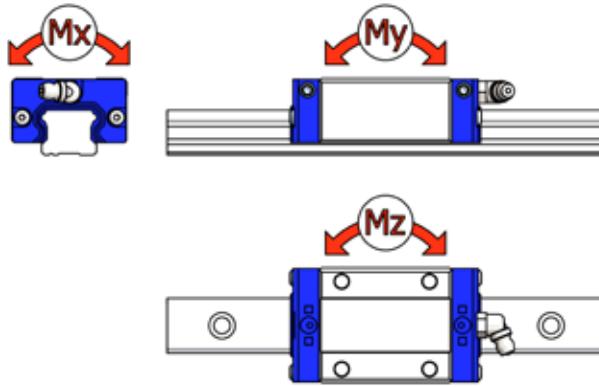

W1	H1	F	Rail [mm]					Load rating					Mass		Code
			Version L			Version C		kN		kNm			kg	kg/ m	
			d	D	h	MR	t	C	C0	MX	MY	MZ	Carriage	Rail	
15	13,0	60	4,5	7,5	5,5	M 5	8,0	9,46	19,90	0,137	0,120	0,120	0,19	1,28	LGBXH15 BN
20	16,3	60	6,0	9,5	8,7	M 6	10,0	14,56	30,96	0,289	0,224	0,224	0,31	2,15	LGBXH20 BN
20	16,3	60	6,0	9,5	8,7	M 6	10,0	18,88	40,11	0,376	0,366	0,366	0,36	2,15	LGBXH20 BL
20	16,3	60	6,0	9,5	8,7	M 6	10,0	22,45	49,61	0,464	0,565	0,565	0,47	2,15	LGBXH20 BE
23	19,2	60	7,0	11,0	12,2	M 6	12,0	20,44	41,73	0,447	0,358	0,358	0,40	2,88	LGBXX25 BN
23	19,2	60	7,0	11,0	12,2	M 6	12,0	26,28	53,63	0,576	0,577	0,577	0,54	2,88	LGBXX25 BL
23	19,2	60	7,0	11,0	12,2	M 6	12,0	29,63	64,30	0,691	0,833	0,833	0,67	2,88	LGBXX25 BE
23	19,2	60	7,0	11,0	12,2	M 6	12,0	20,44	41,73	0,447	0,358	0,358	0,45	2,88	LGBXH25 BN
23	19,2	60	7,0	11,0	12,2	M 6	12,0	26,28	53,63	0,576	0,577	0,577	0,66	2,88	LGBXH25 BL
23	19,2	60	7,0	11,0	12,2	M 6	12,0	29,63	64,30	0,691	0,833	0,833	0,80	2,88	LGBXH25 BE
28	22,8	80	9,0	14,0	12,2	M 8	15,0	30,24	55,50	0,719	0,560	0,560	0,91	4,45	LGBXH30 BN
28	22,8	80	9,0	14,0	12,2	M 8	15,0	39,16	71,88	0,931	0,836	0,836	1,04	4,45	LGBXH30 BL
28	22,8	80	9,0	14,0	12,2	M 8	15,0	43,60	88,18	1,142	1,361	1,361	1,36	4,45	LGBXH30 BE
34	26,0	80	9,0	14,0	12,2	M 8	17,0	44,19	82,66	1,307	0,991	0,991	1,50	6,25	LGBXH35 BN
34	26,0	80	9,0	14,0	12,2	M 8	17,0	53,96	103,29	1,633	1,424	1,424	1,80	6,25	LGBXH35 BL
34	26,0	80	9,0	14,0	12,2	M 8	17,0	59,37	127,68	2,020	2,330	2,330	2,34	6,25	LGBXH35 BE
45	31,1	105	14,0	20,0	17,0	M 12	20,0	59,25	111,30	2,353	1,559	1,559	2,28	9,60	LGBXH45 BN
45	31,1	105	14,0	20,0	17,0	M 12	20,0	70,47	132,39	2,798	2,170	2,170	2,67	9,60	LGBXH45 BL
45	31,1	105	14,0	20,0	17,0	M 12	20,0	81,42	166,87	3,527	3,455	3,455	3,35	9,60	LGBXH45 BE
53	38,0	120	16,0	23,0	20,0	M 14	24,0	71,49	136,62	3,385	2,361	2,361	3,42	13,80	LGBXH55 BN
53	38,0	120	16,0	23,0	20,0	M 14	24,0	96,46	183,14	4,538	4,202	4,202	4,57	13,80	LGBXH55 BL
53	38,0	120	16,0	23,0	20,0	M 14	24,0	130,76	259,71	6,430	6,617	6,617	5,08	13,80	LGBXH55 BE

5.9 LGBXS_B

Linear Guide without ball chain, carriages in block design, flat design height

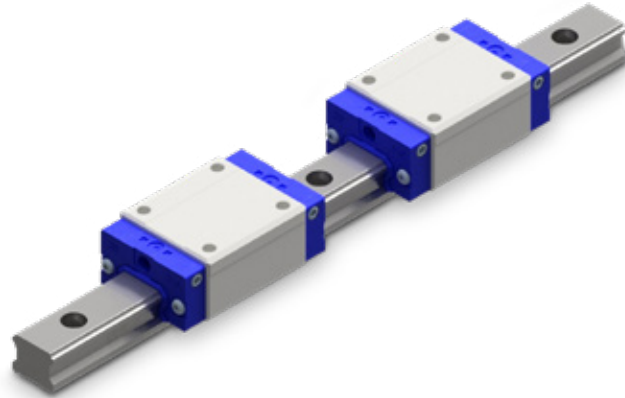

Example of type code

LGBXS 25 BN 2 SS L 02000 N Z1 - 2 - 0 -20.0 N*

		System mm					Carriage mm											
		H	W	W2	E	L	B	J	MQ	I	L1	H2	T1	N	T2	L2	H3	Lx
LGBXS15	BS	24	34	9,5	3,4	40,6	26	--	M 4	4,8	22,2	M 3 x 0,5	5,5	2,5	4,5	4,20	M 3 x 0,5	3,0
LGBXS15	BN	24	34	9,5	3,4	58,6	26	26	M 4	4,8	40,2	M 3 x 0,5	5,5	2,5	4,5	4,20	M 3 x 0,5	3,0
LGBXS15	BL	24	34	9,5	3,4	66,1	26	26	M 4	4,8	47,7	M 3 x 0,5	5,5	2,5	4,5	4,20	M 3 x 0,5	3,0
LGBXS20	BS	28	42	11,0	4,5	49,1	32	--	M 5	5,5	27,5	M 6 x 1,0	5,1	12,3	4,3	4,25	M 6 x 1,0	3,8
LGBXS20	BN	28	42	11,0	4,5	70,1	32	32	M 5	5,5	48,5	M 6 x 1,0	5,1	12,3	4,3	4,25	M 6 x 1,0	3,8
LGBXS25	BS	33	48	12,5	5,8	54,0	35	--	M 6	6,8	32,3	M 6 x 1,0	7,2	12,2	6,4	4,65	M 6 x 1,0	5,0
LGBXS25	BN	33	48	12,5	5,8	79,2	35	35	M 6	6,8	57,5	M 6 x 1,0	7,2	12,2	6,4	4,65	M 6 x 1,0	5,0
LGBXS30	BS	42	60	16,0	7,0	64,2	40	--	M 8	10,0	37,2	M 6 x 1,0	10,0	11,7	5,5	6,00	M 6 x 1,0	5,0
LGBXS30	BN	42	60	16,0	7,0	94,8	40	40	M 8	10,0	67,8	M 6 x 1,0	10,0	11,7	5,5	6,00	M 6 x 1,0	5,0
LGBXS30	BL	42	60	16,0	7,0	105,0	40	40	M 8	10,0	78,0	M 6 x 1,0	10,0	11,7	5,5	6,00	M 6 x 1,0	5,0
LGBXS30	BE	42	60	16,0	7,0	130,5	40	60	M 8	10,0	103,5	M 6 x 1,0	10,0	11,7	5,5	6,00	M 6 x 1,0	5,0
LGBXS35	BS	48	70	18,0	7,5	75,5	50	--	M 8	10,0	44,5	M 6 x 1,0	11,5	11,5	10,5	7,25	M 6 x 1,0	5,0
LGBXS35	BN	48	70	18,0	7,5	111,5	50	50	M 8	10,0	80,5	M 6 x 1,0	11,5	11,5	10,5	7,25	M 6 x 1,0	5,0
LGBXS35	BL	48	70	18,0	7,5	123,5	50	50	M 8	10,0	92,5	M 6 x 1,0	11,5	11,5	10,5	7,25	M 6 x 1,0	5,0
LGBXS35	BE	48	70	18,0	7,5	153,5	50	72	M 8	10,0	122,5	M 6 x 1,0	11,5	11,5	10,5	7,25	M 6 x 1,0	5,0
LGBXS45	BN	60	86	20,5	8,9	129,0	60	60	M 10	15,5	94,0	M 8 x 1,25	14,4	10,8	14,5	8,00	M 8 x 1,25	7,5
LGBXS45	BL	60	86	20,5	8,9	145,0	60	60	M 10	15,5	110,0	M 8 x 1,25	14,4	10,8	14,5	8,00	M 8 x 1,25	7,5
LGBXS45	BE	60	86	20,5	8,9	174,0	60	80	M 10	15,5	139,0	M 8 x 1,25	14,4	10,8	14,5	8,00	M 8 x 1,25	7,5
LGBXS55	BN	70	100	23,5	12,7	155,0	75	75	M 12	18,0	116,0	M 8 x 1,25	14,0	10,8	14,5	10,00	M 8 x 1,25	7,5
LGBXS55	BL	70	100	23,5	12,7	193,0	75	75	M 12	18,0	154,0	M 8 x 1,25	14,0	10,8	14,5	10,00	M 8 x 1,25	7,5
LGBXS55	BE	70	100	23,5	12,7	210,0	75	95	M 12	18,0	171,0	M 8 x 1,25	14,0	10,8	14,5	10,00	M 8 x 1,25	7,5

*Explanation to type code in Chapter 8

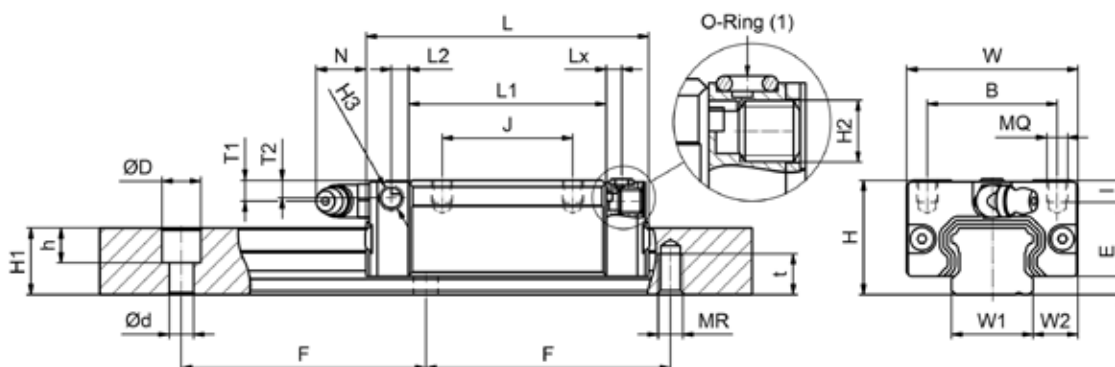
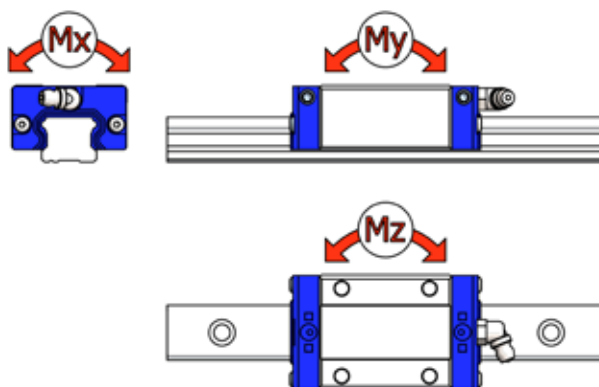

W1	H1	F	Rail [mm]					Load rating						Mass		
			Version L			Version C		kN		kNm			Carriage	Rail		
			d	D	h	MR	t	C	C0	MX	MY	MZ				
15	13,0	60	4,5	7,5	5,5	M 5	8,0	4,70	9,90	0,069	0,032	0,032	0,10	1,28	LGBXS15 BS	
15	13,0	60	4,5	7,5	5,5	M 5	8,0	9,46	19,90	0,137	0,120	0,120	0,17	1,28	LGBXS15 BN	
15	13,0	60	4,5	7,5	5,5	M 5	8,0	11,39	24,05	0,166	0,171	0,171	0,18	1,28	LGBXS15 BL	
20	16,3	60	6,0	9,5	8,7	M 6	10,0	7,49	15,93	0,148	0,066	0,066	0,17	2,15	LGBXS20 BS	
20	16,3	60	6,0	9,5	8,7	M 6	10,0	14,57	30,96	0,289	0,224	0,224	0,22	2,15	LGBXS20 BN	
23	19,2	60	7,0	11,0	9,2	M 6	12,0	10,45	21,34	0,230	0,103	0,103	0,21	2,88	LGBXS25 BS	
23	19,2	60	7,0	11,0	9,2	M 6	12,0	20,44	41,73	0,447	0,358	0,358	0,38	2,88	LGBXS25 BN	
28	22,8	80	9,0	14,0	12,2	M 8	15,0	14,99	27,51	0,356	0,153	0,153	0,50	4,45	LGBXS30 BS	
28	22,8	80	9,0	14,0	12,2	M 8	15,0	30,24	55,50	0,719	0,560	0,560	0,80	4,45	LGBXS30 BN	
28	22,8	80	9,0	14,0	12,2	M 8	15,0	39,16	71,88	0,931	0,836	0,836	0,94	4,45	LGBXS30 BL	
28	22,8	80	9,0	14,0	12,2	M 8	15,0	43,60	88,18	1,142	1,361	1,361	1,16	4,45	LGBXS30 BE	
34	26,0	80	9,0	14,0	12,2	M 8	17,0	21,64	41,43	0,655	0,275	0,275	0,80	6,25	LGBXS35 BS	
34	26,0	80	9,0	14,0	12,2	M 8	17,0	44,19	82,66	1,307	0,991	0,991	1,20	6,25	LGBXS35 BN	
34	26,0	80	9,0	14,0	12,2	M 8	17,0	53,96	103,29	1,633	1,424	1,424	1,40	6,25	LGBXS35 BL	
34	26,0	80	9,0	14,0	12,2	M 8	17,0	59,37	127,68	2,020	2,330	2,330	1,84	6,25	LGBXS35 BE	
45	31,1	105	14,0	20,0	17,0	M 12	20,0	59,25	111,30	2,353	1,559	1,559	1,64	9,60	LGBXS45 BN	
45	31,1	105	14,0	20,0	17,0	M 12	20,0	70,47	132,39	2,798	2,170	2,170	1,93	9,60	LGBXS45 BL	
45	31,1	105	14,0	20,0	17,0	M 12	20,0	81,42	166,87	3,527	3,455	3,455	2,42	9,60	LGBXS45 BE	
53	38,0	120	16,0	23,0	20,0	M 14	24,0	71,49	136,62	3,385	2,361	2,361	2,67	13,80	LGBXS55 BN	
53	38,0	120	16,0	23,0	20,0	M 14	24,0	96,46	183,14	4,538	4,202	4,202	3,57	13,80	LGBXS55 BL	
53	38,0	120	16,0	23,0	20,0	M 14	24,0	130,76	259,71	6,430	6,617	6,617	3,97	13,80	LGBXS55 BE	

5.10 LGBXH_TN

Wide Linear Guide without ball chain, flange type, normal design height

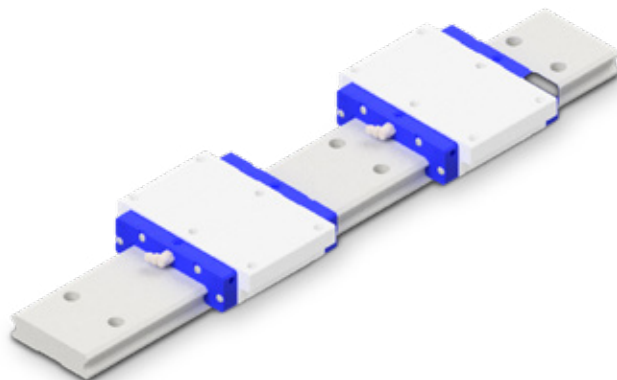

Example of type code

LGBXH 35 TN 2 BBL 01640 N Z1 - 1 - 0 - 20.0 N*

	System mm						Carriage mm													
	H	W	W2	E	L	B	J	J1	MQ	ih	I	L1	H2	T1	N	T2	L2	H3	Lx	
LGBXH21 TN	21	68	15,5	3,0	58,8	60	29	29	M 5	4,4	8,0	40,6	M 6 x 1,0	5,1	12,0	4,5	4,20	M 3 x 0,5	3,0	
LGBXH27 TN	27	80	19,0	3,0	72,6	70	40	40	M 6	5,4	9,0	51,8	M 6 x 1,0	6,0	12,0	6,0	4,25	M 3 x 0,5	3,8	
LGBXH35 TN	35	120	25,5	4,0	103,0	107	60	60	M 8	7,0	10,0	78,0	M 6 x 1,0	8,7	12,0	8,0	4,65	M 6 x 1,0	5,0	

*Explanation to type code in Chapter 8

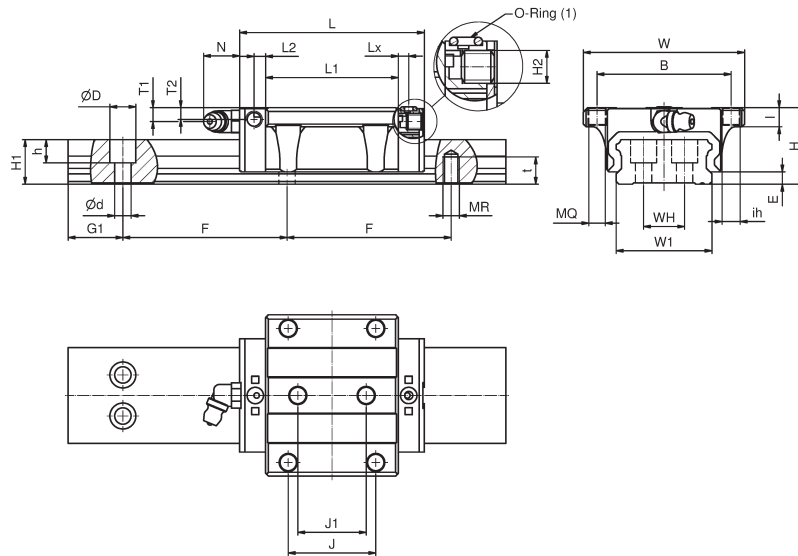
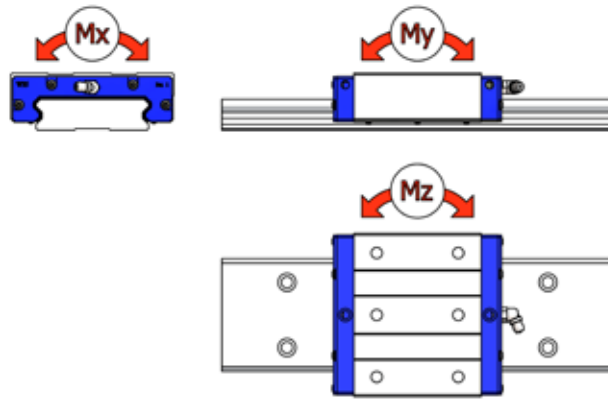

Rail [mm]									Load rating					Mass		
W1	H1	F	WH	Version L			Version C		kN		kNm			kg	kg/ m	
				d	D	h	MR	t	C	C0	MX	MY	MZ	Carriage	Rail	
37	11	50	22	4,5	7,5	5,3	M 5	8,0	7,34	13,09	0,233	0,071	0,071	0,26	3,00	LGBXH21 TN
42	15	60	24	4,5	7,5	5,3	M 5	8,0	13,02	21,90	0,457	0,162	0,162	0,52	4,60	LGBXH27 TN
69	19	80	40	7,0	11,0	9,0	M 6	12,0	28,98	51,27	1,756	0,579	0,579	1,45	9,50	LGBXH35 TN

5.11 LGBXH_WN

Wide Linear Guide without ball chain, block type, normal design height

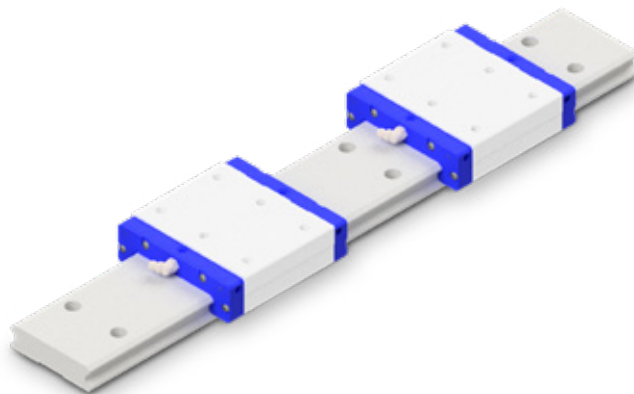

Example of type code

LGBXH35WN2BBL01640NZ1-1-0-20.0N*

		System mm					Carriage mm												
		H	W	W2	E	L	B	J	J1	MQ	I	L1	H2	T1	N	T2	L2	H3	Lx
LGBXH21	WN	21	54	8,5	3,0	58,8	31	19	19	M 5	6,0	40,6	M 6 x 1,0	5,1	12,0	4,5	4,20	M 3 x 0,5	3,0
LGBXH27	WN	27	62	10,0	3,0	72,6	46	32	32	M 6	6,0	51,8	M 6 x 1,0	6,0	12,0	6,0	4,25	M 3 x 0,5	3,8
LGBXH35	WN	35	100	15,5	4,0	103,0	76	50	50	M 8	8,0	78,0	M 6 x 1,0	8,7	12,0	8,0	4,65	M 6 x 1,0	5,0

*Explanation to type code in Chapter 8

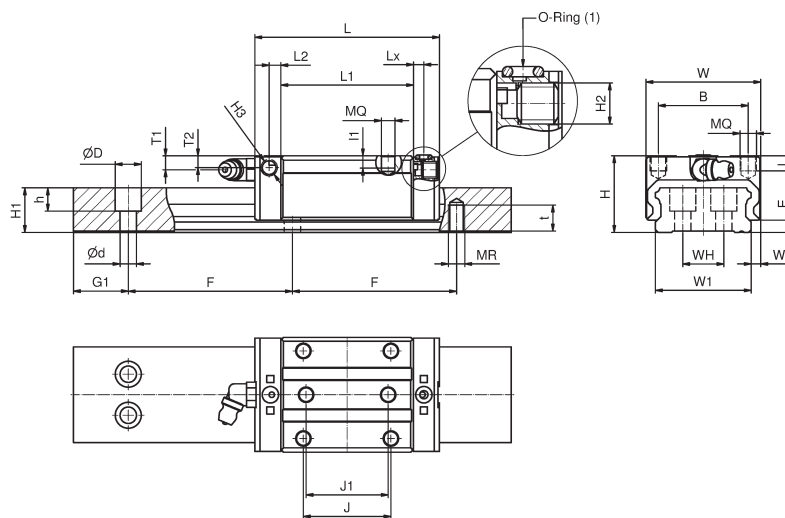
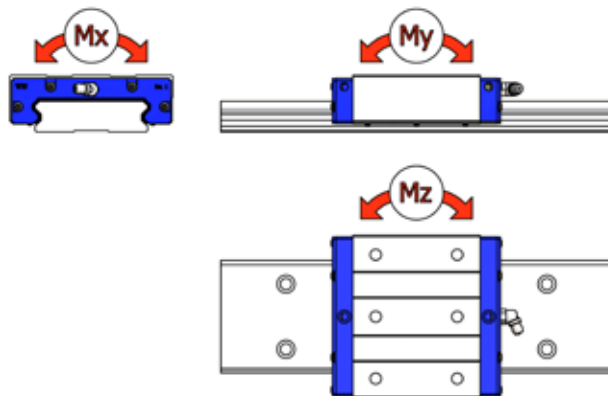

Rail [mm]									Load rating					Mass		
W1	H1	F	WH	Version L			Version C		kN		kNm			kg	kg/ m	
				d	D	h	MR	t	C	C0	MX	MY	MZ	Carriage	Rail	
37	11	50	22	4,5	7,5	5,3	M 5	8,0	7,49	13,29	0,237	0,072	0,072	0,20	3,00	LGBXH21 WN
42	15	60	24	4,5	7,5	5,3	M 5	8,0	13,28	22,23	0,464	0,165	0,165	0,35	4,60	LGBXH27 WN
69	19	80	40	7,0	11,0	9,0	M 6	12,0	29,56	52,04	1,782	0,587	0,587	1,10	9,50	LGBXH35 WN

5.12 LGMC...B

Miniature guide (corrosion-resistant) with ball chain narrow version

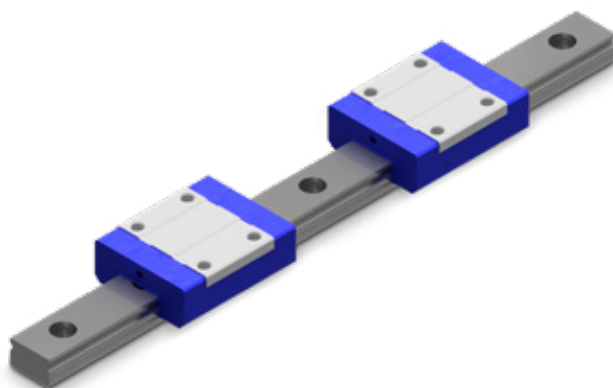

Example of type code

LGMC 12 BN 2 BB L 00195 N Z1 - 2 - 0 - 10.0 N*

		System mm					Carriage mm								
		H	W	W2	E	L	B	J	MQ	I	L1	H2	T1	N	
LGMC09	BN	10	20	5,5	2,2	30,8	15	10	M 3	2,8	19,5	Ø 1,5	2,4	--	
LGMC09	BL	10	20	5,5	2,2	40,5	15	16	M 3	2,8	29,2	Ø 1,5	2,4	--	
LGMC12	BN	13	27	7,5	2,0	34,0	20	15	M 3	3,2	20,3	Ø 2,0	3,0	--	
LGMC12	BL	13	27	7,5	2,0	47,0	20	20	M 3	3,2	33,3	Ø 2,0	3,0	--	
LGMC15	BN	16	32	8,5	4,0	42,0	25	20	M 3	3,5	25,3	M 3 x 0,5	3,5	5	
LGMC15	BL	16	32	8,5	4,0	59,8	25	25	M 3	3,5	43,1	M 3 x 0,5	3,5	5	

*Explanation to type code in Chapter 8

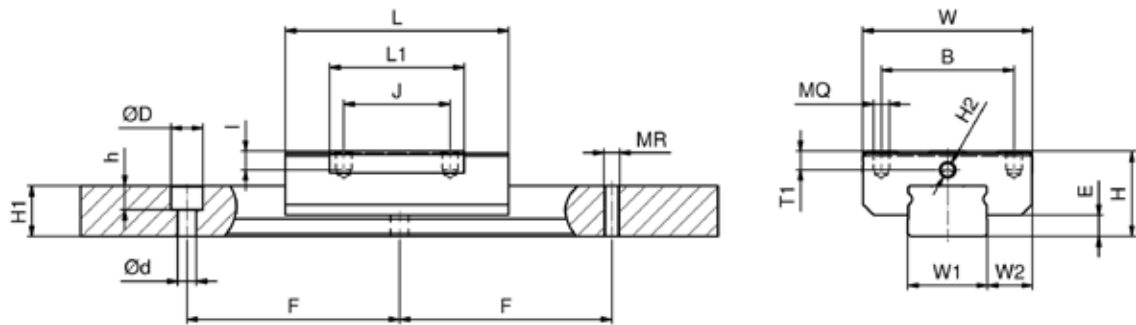
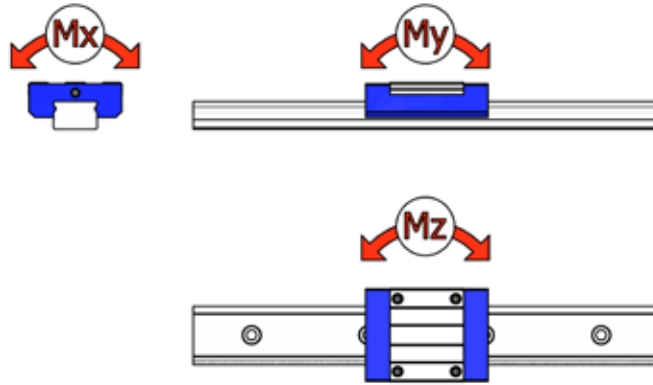

W1	H1	F	WH	Rail [mm]					kN		Load rating kNm			Mass			
				d	D	h	Version L	Version C	C	C0	MX	MY	MZ	kg Carriage	kg/ m Rail		
9	6,05	20	--	3,5	6,0	3,30	M 4	6,05	2,68	2,28	0,0105	0,0084	0,0084	0,014	0,39	LGMC09	BN
9	6,05	20	--	3,5	6,0	3,30	M 4	6,05	3,47	3,28	0,0149	0,0169	0,0169	0,020	0,39	LGMC09	BL
12	7,25	25	--	3,5	6,0	4,30	M 4	7,25	3,97	3,46	0,0228	0,0118	0,0118	0,029	0,63	LGMC12	BN
12	7,25	25	--	3,5	6,0	4,30	M 4	7,25	5,66	5,21	0,0337	0,0278	0,0278	0,047	0,63	LGMC12	BL
15	9,50	40	--	3,5	6,0	4,50	M 5	9,50	6,60	5,66	0,0397	0,0258	0,0258	0,047	1,05	LGMC15	BN
15	9,50	40	--	3,5	6,0	4,50	M 5	9,50	8,94	7,94	0,0556	0,0546	0,0546	0,078	1,05	LGMC15	BL

5.13 LGMC_W

Miniature guide (corrosion-resistant) with ball chain wide version

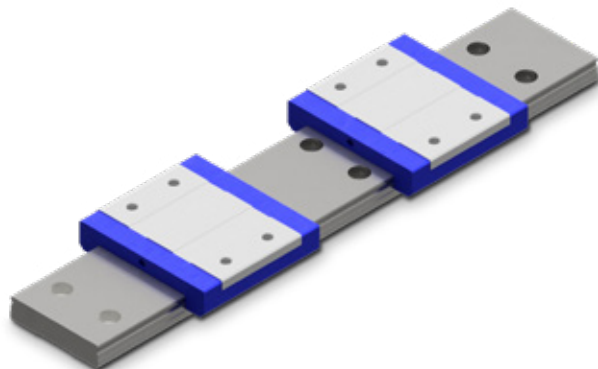

Example of type code

LGMC 12WN2BB L00190 N Z1 - 2 - 0 - 15.0 N*

H		System mm					Carriage mm							
		H	W	W2	E	L	B	J	MQ	I	L1	H2	T1	N
LGMC09	WN	12	30	6,0	3,4	39,0	21	12	M 3	2,8	26,7	Ø 1,5	2,3	--
LGMC09	WL	12	30	6,0	3,4	51,0	23	24	M 3	2,8	38,7	Ø 1,5	2,3	--
LGMC12	WN	14	40	8,0	3,8	44,5	28	15	M 3	3,5	30,5	Ø 2,0	3,0	--
LGMC12	WL	14	40	8,0	3,8	59,1	28	28	M 3	3,5	45,1	Ø 2,0	3,0	--
LGMC15	WN	16	60	9,0	4,0	55,5	45	20	M 4	4,5	38,1	M 3 x 0,5	3,5	5
LGMC15	WL	16	60	9,0	4,0	74,7	45	35	M 4	4,5	57,3	M 3 x 0,5	3,5	5

*Explanation to type code in Chapter 8

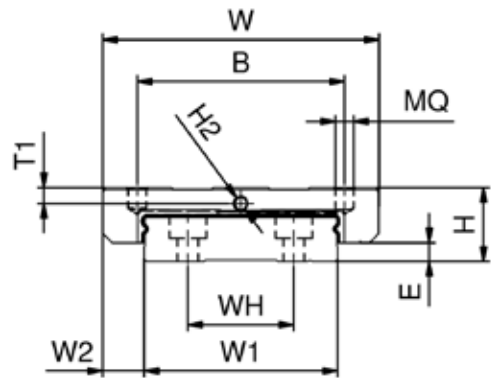
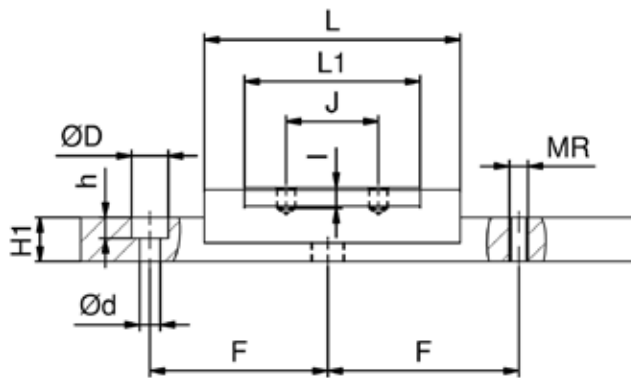
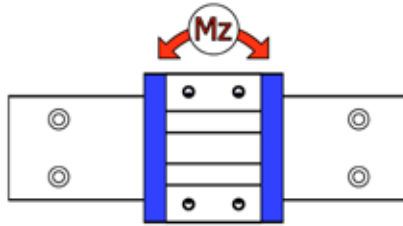
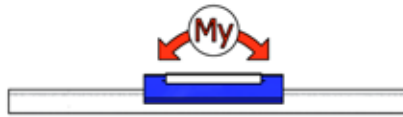
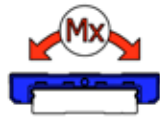

W1	H1	F	WH	Rail [mm]					kN		Load rating kNm			Mass		
				d	D	h	MR	t	C	C0	MX	MY	MZ	Carriage kg	Rail kg/m	
18	7,50	30	--	3,5	6,0	4,50	M 4	7,50	3,23	3,27	0,0310	0,0149	0,0149	0,030	0,98	LGMC09 WN
18	7,50	30	--	3,5	6,0	4,50	M 4	7,50	4,32	4,27	0,0407	0,0273	0,0273	0,042	0,98	LGMC09 WL
24	8,70	40	--	4,5	8,0	4,50	M 5	8,70	5,41	5,26	0,0655	0,0260	0,0260	0,052	1,53	LGMC12 WN
24	8,70	40	--	4,5	8,0	4,50	M 5	8,70	7,09	6,99	0,0873	0,0481	0,0481	0,076	1,53	LGMC12 WL
42	9,50	40	23	4,5	8,0	4,50	M 5	9,50	9,03	8,48	0,1737	0,0506	0,0506	0,111	2,97	LGMC15 WN
42	9,50	40	23	4,5	8,0	4,50	M 5	9,50	11,31	10,92	0,2233	0,0968	0,0968	0,165	2,97	LGMC15 WL

5.14 LGMX_B

Miniature guide (corrosion-resistant) without ball chain narrow version

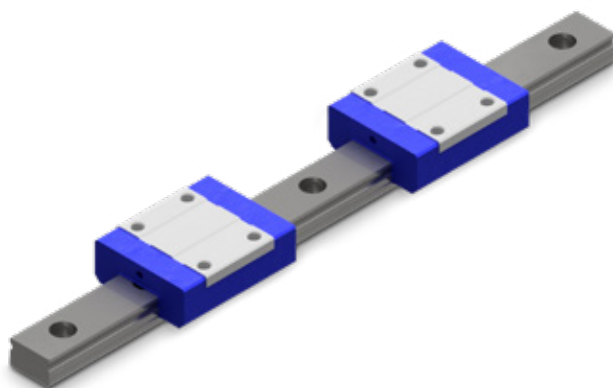

Example of type code

LGMX 12 BN 2 BBL 00195 N Z1 - 2 - 0 - 10.0 N*

		System mm					Carriage mm							
		H	W	W2	E	L	B	J	MQ	I	L1	H2	T1	N
LGMX07	BN	8	17	5,0	1,5	24,0	12	8	M 2	2,0	13,0	Ø 1,1	1,7	--
LGMX09	BN	10	20	5,5	2,2	30,8	15	10	M 3	2,8	19,5	Ø 1,5	2,4	--
LGMX09	BL	10	20	5,5	2,2	40,5	15	16	M 3	2,8	29,2	Ø 1,5	2,4	--
LGMX12	BN	13	27	7,5	2,0	34,0	20	15	M 3	3,2	20,3	Ø 2,0	3,0	--
LGMX12	BL	13	27	7,5	2,0	47,0	20	20	M 3	3,2	33,3	Ø 2,0	3,0	--
LGMX15	BN	16	32	8,5	4,0	42,0	25	20	M 3	3,5	25,3	M 3 x 0,5	3,5	5
LGMX15	BL	16	32	8,5	4,0	59,8	25	25	M 3	3,5	43,1	M 3 x 0,5	3,5	5

*Explanation to type code in Chapter 8

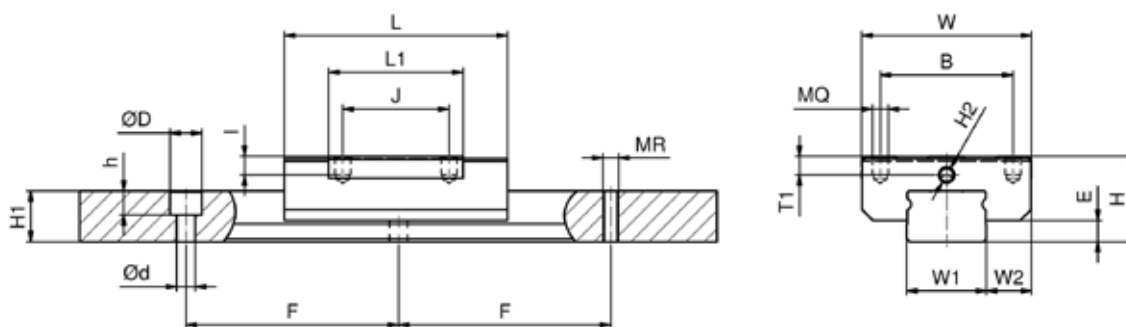
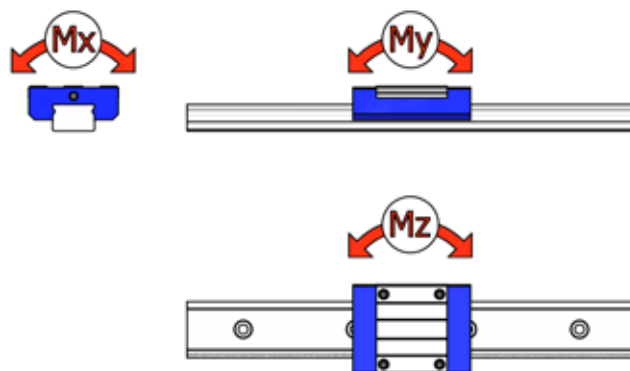

W1	H1	F	WH	Rail [mm]					Load rating					Mass			
				d	D	h	Version L	Version C	kN		kNm			kg	kg/ m		
							MR	t	C	C0	MX	MY	MZ	Carriage	Rail		
7	4,70	15	--	2,4	4,4	2,40	M 3	4,70	1,30	1,52	0,0050	0,0031	0,0031	0,010	0,25	LGMX07	BN
9	6,05	20	--	3,5	6,0	3,30	M 4	6,05	2,03	2,28	0,0105	0,0084	0,0084	0,014	0,39	LGMX09	BN
9	6,05	20	--	3,5	6,0	3,30	M 4	6,05	2,78	3,28	0,0149	0,0169	0,0169	0,020	0,39	LGMX09	BL
12	7,25	25	--	3,5	6,0	4,30	M 4	7,25	3,32	3,46	0,0228	0,0118	0,0118	0,029	0,63	LGMX12	BN
12	7,25	25	--	3,5	6,0	4,30	M 4	7,25	4,46	5,21	0,0337	0,0278	0,0278	0,047	0,63	LGMX12	BL
15	9,50	40	--	3,5	6,0	4,50	M 5	9,50	5,51	5,66	0,0397	0,0258	0,0258	0,047	1,05	LGMX15	BN
15	9,50	40	--	3,5	6,0	4,50	M 5	9,50	7,25	7,94	0,0556	0,0546	0,0546	0,078	1,05	LGMX15	BL

5.15 LGMX_W

Miniature guide (corrosion-resistant) without ball chain, wide version

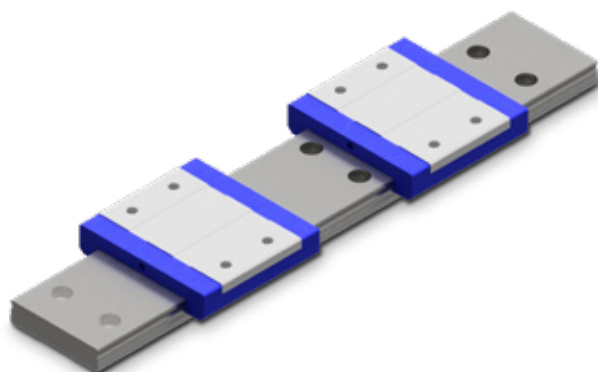

Example of type code

LGMX 12 WN 2 BB L 00190 N Z1 - 2 - 0 - 15.0 N*

		System mm					Carriage mm								
		H	W	W2	E	L	B	J	MQ	I	L1	H2	T1	N	
LGMX09	WN	12	30	6,0	3,4	39,0	21	12	M 3	2,8	26,7	Ø 1,5	2,3	--	
LGMX09	WL	12	30	6,0	3,4	51,0	23	24	M 3	2,8	38,7	Ø 1,5	2,3	--	
LGMX12	WN	14	40	8,0	3,8	44,5	28	15	M 3	3,5	30,5	Ø 2,0	3,0	--	
LGMX12	WL	14	40	8,0	3,8	59,1	28	28	M 3	3,5	45,1	Ø 2,0	3,0	--	
LGMX15	WN	16	60	9,0	4,0	55,5	45	20	M 4	4,5	38,1	M 3 x 0,5	3,5	5	
LGMX15	WL	16	60	9,0	4,0	74,7	45	35	M 4	4,5	57,3	M 3 x 0,5	3,5	5	

*Explanation to type code in Chapter 8

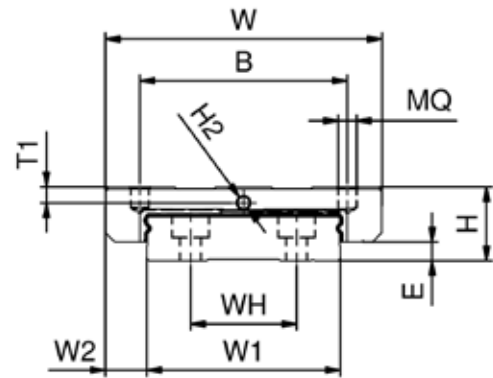
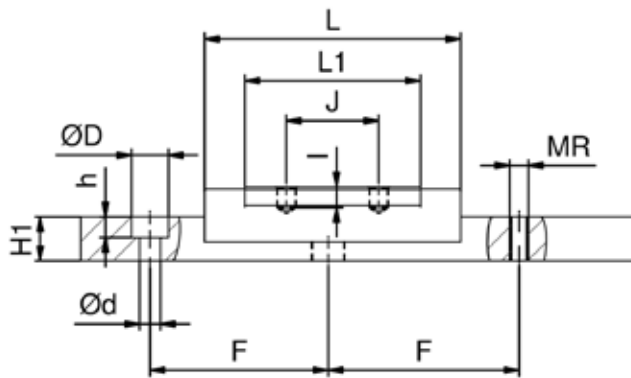
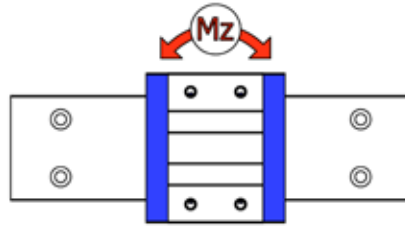
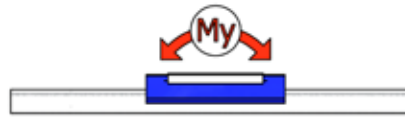
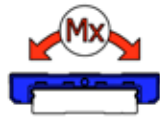

W1	H1	F	WH	Rail [mm]					Load rating					Mass		LGMX	WN	WL
				d	D	h	MR	t	kN		kNm			kg	kg/ m			
				Version L			Version C		C	C0	MX	MY	MZ	Carriage	Rail			
18	7,50	30	--	3,5	6,0	4,50	M 4	7,50	2,63	3,27	0,0310	0,0149	0,0149	0,030	0,98	LGMX09	WN	
18	7,50	30	--	3,5	6,0	4,50	M 4	7,50	3,37	4,27	0,0407	0,0273	0,0273	0,042	0,98	LGMX09	WL	
24	8,70	40	--	4,5	8,0	4,50	M 5	8,70	4,36	5,26	0,0655	0,0260	0,0260	0,052	1,53	LGMX12	WN	
24	8,70	40	--	4,5	8,0	4,50	M 5	8,70	5,66	6,99	0,0873	0,0481	0,0481	0,076	1,53	LGMX12	WL	
42	9,50	40	23	4,5	8,0	4,50	M 5	9,50	7,49	8,48	0,1737	0,0506	0,0506	0,111	2,97	LGMX15	WN	
42	9,50	40	23	4,5	8,0	4,50	M 5	9,50	9,03	10,92	0,2233	0,0968	0,0968	0,165	2,97	LGMX15	WL	

5.16 Standard rail length

Rails for SNR Linear Guides are produced in standard lengths. Table 5.1 shows the standard length as a function of the design size.

Table 5.1 Standard rail length of SNR Linear Guides

	LGBR...							LGBW...			LGMR...				LGMW...		
	15	20	25	30	35	45	55	21	27	35	07	09	12	15	09	12	15
Standard length	160	160	160	280	280	360	420	130	160	280	40	55	70	70	50	70	70
	220	220	220	360	360	465	540	180	220	360	55	75	95	110	80	110	110
	280	280	280	440	440	570	660	230	280	440	70	95	120	150	110	150	150
	340	340	340	520	520	675	780	280	340	520	85	115	145	190	140	190	190
	400	400	400	600	600	780	900	330	400	600	100	135	170	230	170	230	230
	460	460	460	680	380	885	1020	380	460	680	115	155	195	270	200	270	270
	520	520	520	760	760	990	1140	430	520	760	130	175	220	310	230	310	310
	580	580	580	840	840	1095	1260	480	580	840	160	195	245	350	260	350	350
	640	640	640	920	920	1200	1380	530	640	920	210	235	270	390	290	390	390
	700	700	700	1000	1000	1305	1500	580	700	1000	255	275	295	430	320	430	430
	760	760	760	1080	1080	1410	1620	630	760	1080	300	315	345	470	380	470	470
	820	820	820	1160	1160	1515	1740	780	820	1160	360	355	395	510	440	550	550
	880	880	880	1240	1240	1620	1860	880	880	1240	420	395	445	550	500	630	630
	940	940	940	1320	1320	1725	1980	980	940	1320		435	495	590	560	710	710
	1000	1000	1000	1400	1400	1830	2100	1080	1000	1400		475	545	630	620	790	790
	1060	1060	1060	1480	1480	1935	2220	1180	1060	1480		555	595	670	680	870	870
	1120	1120	1120	1560	1560	2040	2340	1280	1120	1560		635	645	750	740	950	950
	1180	1180	1180	1640	1640	2145	2460	1380	1180	1640		715	695	830	800	1030	1030
	1240	1240	1240	1720	1720	2250	2580	1480	1240	1720		795	745	910	860	1110	1110
	1300	1300	1300	1800	1800	2355	2700	1580	1300	1800		875	795	990	920	1190	1190
	1360	1360	1360	1880	1880	2460	2820	1680	1360	1880			845	1070	980	1270	1270
	1420	1420	1420	1960	1960	2565	2940	1780	1420	1960			945	1150	1040	1350	1350
	1480	1480	1480	2040	2040	2670	3060	1880	1480	2040			995	1230		1430	1430
	1540	1540	1540	2200	2200	2775	3180	1980	1540	2200			1095	1310			
	1600	1600	1600	2360	2360	2880	3300	2080	1600	2360			1195	1390			
	1720	1720	1720	2520	2520	2985	3420	2180	1720	2520			1295				
	1840	1840	1840	2680	2680	3090	3540	2280	1840	2680			1395				
	1960	1960	1960	2840	2840	3195	3660	2380	1960	2840							
	2080	2080	2080	3000	3000	3300	3780	2480	2080	3000							
	2200	2200	2200	3160	3160	3405		2580	2200	3160							
	2320	2320	2320	3320	3320	3510		2680	2320	3320							
	2440	2440	2440	3480	3480	3615		2780	2440	3480							
	2560	2560	2560	3640	3640	3720		2880	2560	3640							
	2680	2680	2680	3800	3800	3825			2680	3800							
	2800	2800	2800						2800								
	2920	2920	2920						2920								
	3040	3040	3040						3040								
3280	3280	3280						3280									
3520	3520	3520						3520									
3760	3760	3760						3760									
Max. length	3940	3940	3940	3960	3960	3930	3900	2980	3940	3960	435	1995	1995	1990	1970	1990	1990
F	60	60	60	80	80	105	120	50	60	80	15	20	25	40	30	40	40
G1=G2	20,0	20,0	20,0	20,0	20,0	22,5	30,0	15,0	20,0	20,0	5,0	7,5	10,0	15,0	10,0	15,0	15,0

5.17 Rail arrangement

Figure 5.1 shows the definition of the position of dimensions G1 and G2 for different rail arrangements.

Suffixes: -1 / -3

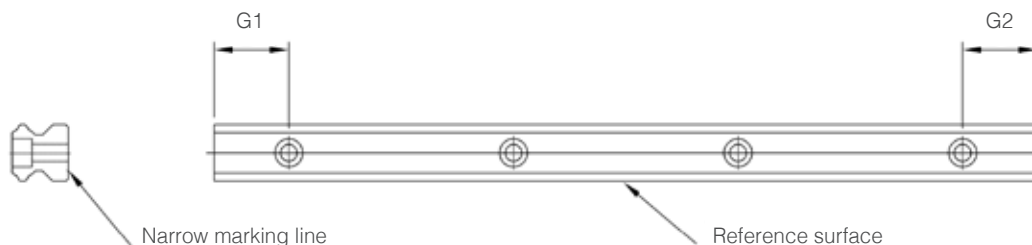

Suffixes: -2 / -4

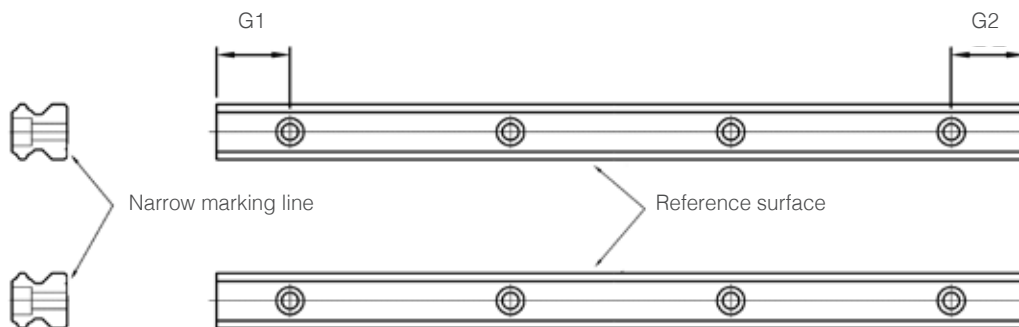

Figure 5.1 Position of the dimensions G1, G2

The following versions of Linear Guide systems can be ordered:

- One-segment rail in standard length
- One-segment rail in special length, symmetrical ($G1=G2$)
- One-segment rail in special length, asymmetrical ($G1 \neq G2$: $G1=...$, $G2=...$)
- Arbitrarily jointed rail ($G1=G2$). Rails with a length that exceeds the specified maximum standard length for rails delivered in several segments with joints (see Chapter 3.2). The number of segments is defined by us.
- Jointed rail according to customer specifications. The number of segments is determined by customer specifications. The total length of the rail must be specified when two or several segments with joints are ordered.

6 Accessories

6.1 Sealing Options

6.1.1 Description

Linear Guides are exposed to a variety of pollution types during operation. Pollution can be caused by solid or liquid foreign particles. The purpose of the sealing system is:

- To prevent penetration of foreign particles of any kind
- To distribute the lubricant evenly over the raceways
- To minimise the loss of lubricant

SNR Linear Guides can be combined with a multitude of sealing options to provide an optimal sealing system for various applications. The following sealing elements are available for these combinations:

End seal*

- Two lip seal
- Rubber - metal - part
- Front seal of the carriage against contamination from outside
- Minimization of lubricant loss
- Sealing for normal environmental conditions

Inner seal*

- Two lip seal
- Sealing of the carriage's inside against the entry of contamination by deposits in the rail holes
- Reduction of the volume in which the lubricant can be distributed
- Minimization of lubricant loss
- Sealing for all environmental conditions

Side seal*

- Two lip seal
- Sealing of the carriage's inside against the entry of contamination from below
- Minimization of lubricant loss
- Sealing for all environmental conditions, especially in vertical and overhead position

Multi - Layer - Seal MLS

- Sealing element of several oil-impregnated laminate layers
- Sealing in case of extreme heavy contamination
- Useful application in combination with double seals or double seals and scraper

Double seal

- Combination from two end seals and spacer element
- Sealing in case of very heavy contamination
- Additional mounting of scrapers possible

Scraper

- Metal scraper
- Scrapers have no contact with the rail
- Sealing against heavy dirt and chips
- Not suitable as single sealing

* Standard sealing (miniature guides and wide Standard Linear Guides without inner seal)

6.1.2 Combination options

Table 6.1 provides a summary of the various sealing options for SNR Linear Guides

Table 6.1 Lubrication adapter

Description	LGB_B/F	LGB_T/W	LGM_B/W	Sealing structure
SS	S	-	-	End seals on both sides, inner and side seals
AA	X	X	X	No sealing
UU	X	X	-	End seals on both sides
BB	X	S	S	End seals on both sides and side seals
EE	X	X ¹	-	Double end seals on both sides, inner and side seals
FF	X	X ¹	-	End seals on both sides, inner and side seals, scraper on both sides
GG	X	X ¹	-	Double end seals on both sides, inner and side seals, scraper on both sides
ES	X	X ¹	-	Double end seals on one side, inner and side seals
FS	X	X ¹	-	End seals on one side, inner and side seals, scraper on one side
GS	X	X ¹	-	Double end seals on one side, inner and side seals, scraper on one side
VV	X	-	-	Double end seals on both sides, inner and side seals, MLS on both sides
WW	X	-	-	Double end seals on both sides, inner and side seals, scraper and MLS on both sides
XX	X	X	-	Special sealing option (description of customer specification required)

S Standard sealing
 X Sealing option available
 - Sealing option not available
¹ without inner seal

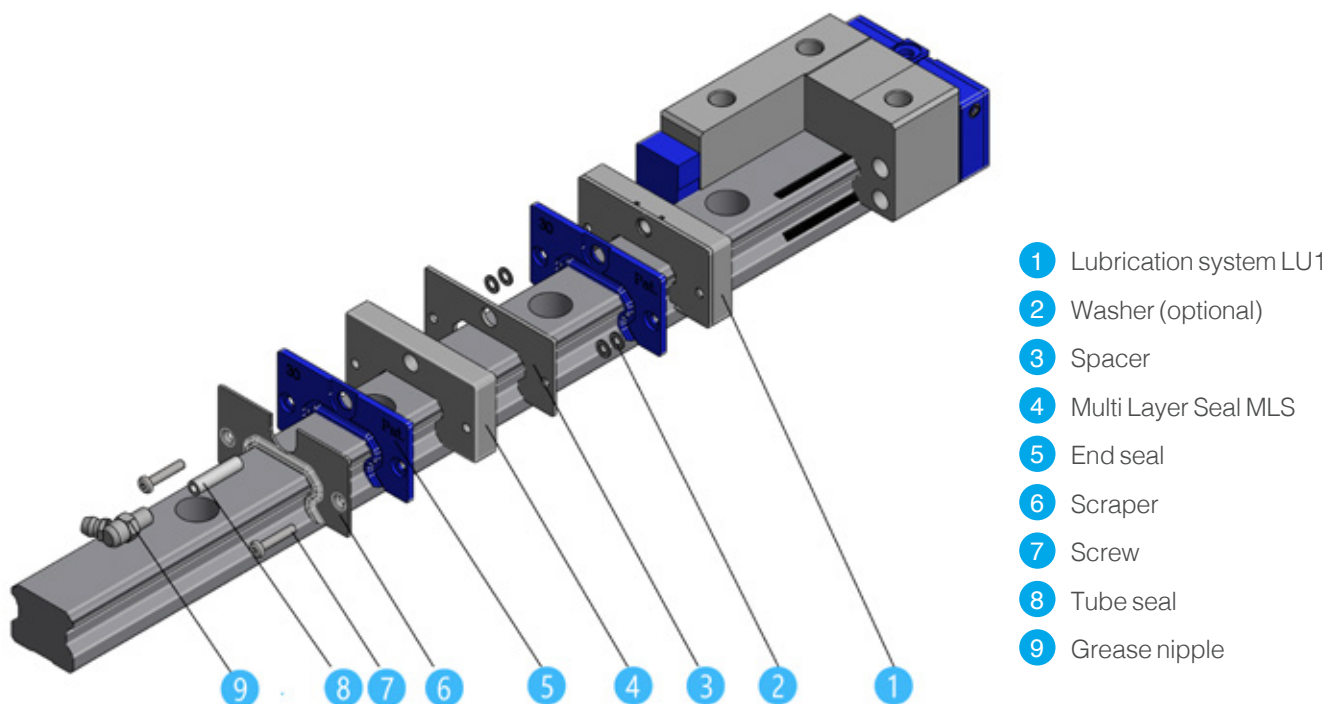

Figure 6.1 Sealing arrangement

Starting from the standard seal, seal kits are available for modification of the seal option on standard carriages. One seal kit contains all the parts required for assembling the seal for one side of the carriage. For assembly, the sequence of components shown in Figure 6.1 must be observed. Correct centering of the assembled seals must be carried out on a standard rail. Table 6.2 contains a summary of the available seal kits including the ID numbers.

Table 6.2 Sealing kits

Type	Sealing option	Sealing kit			
		Designation	ID Number	with additional lubrication system LU1 Designation	ID Number
LGB_15 B/F	S - Standard sealing	-	-	LGB-AC-15-KIT-S+LU1	479021
	E - Double seal	LGB-AC-15-KIT-E	479044	LGB-AC-15-KIT-E+LU1	479052
	F - Scraper	LGB-AC-15-KIT-F	479061	LGB-AC-15-KIT-F+LU1	479068
	G - Double seal, Scraper	LGB-AC-15-KIT-G	479079	LGB-AC-15-KIT-G+LU1	479088
	V - Double seal, Multi-Seal	LGB-AC-15-KIT-V	479003	LGB-AC-15-KIT-V+LU1	478993
	W - Double seal, Multi-Layer-Seal, Scraper	LGB-AC-15-KIT-W	479018	LGB-AC-15-KIT-W+LU1	479010
LGB_20 B/F	S - Standard sealing	-	-	LGB-AC-20-KIT-S+LU1	479022
	E - Double seal	LGB-AC-20-KIT-E+LU1	479055	LGB-AC-20-KIT-E	479045
	F - Scraper	LGB-AC-20-KIT-F+LU1	479070	LGB-AC-20-KIT-F	479062
	G - Double seal, Scraper	LGB-AC-20-KIT-G+LU1	479087	LGB-AC-20-KIT-G	479080
	V - Double seal, Multi-Seal	LGB-AC-20-KIT-V	479002	LGB-AC-20-KIT-V+LU1	478992
	W - Double seal, Multi-Layer-Seal, Scraper	LGB-AC-20-KIT-W	479017	LGB-AC-20-KIT-W+LU1	479009
LGB_25 B/F	S - Standard sealing	-	-	LGB-AC-25-KIT-S+LU1	479023
	E - Double seal	LGB-AC-25-KIT-E	479046	LGB-AC-25-KIT-E+LU1	479056
	F - Scraper	LGB-AC-25-KIT-F	479063	LGB-AC-25-KIT-F+LU1	479071
	G - Double seal, Scraper	LGB-AC-25-KIT-G	479082	LGB-AC-25-KIT-G+LU1	479086
	V - Double seal, Multi-Seal	LGB-AC-25-KIT-V	479001	LGB-AC-25-KIT-V+LU1	478991
	W - Double seal, Multi-Layer-Seal, Scraper	LGB-AC-25-KIT-W	479016	LGB-AC-25-KIT-W+LU1	479008
LGB_30 B/F	S - Standard sealing	-	-	LGB-AC-30-KIT-S+LU1	479024
	E - Double seal	LGB-AC-30-KIT-E	479047	LGB-AC-30-KIT-E+LU1	479057
	F - Scraper	LGB-AC-30-KIT-F	479064	LGB-AC-30-KIT-F+LU1	479072
	G - Double seal, Scraper	LGB-AC-30-KIT-G	479083	LGB-AC-30-KIT-G+LU1	479081
	V - Double seal, Multi-Seal	LGB-AC-30-KIT-V	479000	LGB-AC-30-KIT-V+LU1	478988
	W - Double seal, Multi-Layer-Seal, Scraper	LGB-AC-30-KIT-W	479015	LGB-AC-30-KIT-W+LU1	479007
LGB_35 B/F	S - Standard sealing	-	-	LGB-AC-35-KIT-S+LU1	479025
	E - Double seal	LGB-AC-35-KIT-E	479049	LGB-AC-35-KIT-E+LU1	479058
	F - Scraper	LGB-AC-35-KIT-F	479065	LGB-AC-35-KIT-F+LU1	479075
	G - Double seal, Scraper	LGB-AC-35-KIT-G	479084	LGB-AC-35-KIT-G+LU1	479078
	V - Double seal, Multi-Seal	LGB-AC-35-KIT-V	478997	LGB-AC-35-KIT-V+LU1	478987
	W - Double seal, Multi-Layer-Seal, Scraper	LGB-AC-35-KIT-W	479014	LGB-AC-35-KIT-W+LU1	479006
LGB_45 B/F	S - Standard sealing	-	-	LGB-AC-45-KIT-S+LU1	479026
	E - Double seal	LGB-AC-45-KIT-E	479050	LGB-AC-45-KIT-E+LU1	479059
	F - Scraper	LGB-AC-45-KIT-F	479066	LGB-AC-45-KIT-F+LU1	479076
	G - Double seal, Scraper	LGB-AC-45-KIT-G	479085	LGB-AC-45-KIT-G+LU1	479074
	V - Double seal, Multi-Seal	LGB-AC-45-KIT-V	478995	LGB-AC-45-KIT-V+LU1	478986
	W - Double seal, Multi-Layer-Seal, Scraper	LGB-AC-45-KIT-W	479013	LGB-AC-45-KIT-W+LU1	479005
LGB_55 B/F	S - Standard sealing	-	-	LGB-AC-55-KIT-S+LU1	479027
	E - Double seal	LGB-AC-55-KIT-E	479051	LGB-AC-55-KIT-E+LU1	479060
	F - Scraper	LGB-AC-55-KIT-F	479067	LGB-AC-55-KIT-F+LU1	479077
	G - Double seal, Scraper	LGB-AC-55-KIT-G	479089	LGB-AC-55-KIT-G+LU1	479069
	V - Double seal, Multi-Seal	LGB-AC-55-KIT-V	478994	LGB-AC-55-KIT-V+LU1	478983
	W - Double seal, Multi-Layer-Seal, Scraper	LGB-AC-55-KIT-W	479011	LGB-AC-55-KIT-W+LU1	479004
LGB_21 T/W	B - Standard saling	-	-	LGB-AC-21W-KIT-B+LU1	in preparation
	E - Double seal	LGB-AC-21W-KIT-E	in preparation	LGB-AC-21W-KIT-E+LU1	in preparation
	F - Scraper	LGB-AC-21W-KIT-F	in preparation	LGB-AC-21W-KIT-F+LU1	in preparation
	G - Double seal, Scraper	LGB-AC-21W-KIT-G	in preparation	LGB-AC-21W-KIT-G+LU1	in preparation
LGB_27 T/W	B - Standard saling	-	-	LGB-AC-27W-KIT-B+LU1	in preparation
	E - Double seal	LGB-AC-27W-KIT-E	in preparation	LGB-AC-27W-KIT-E+LU1	in preparation
	F - Scraper	LGB-AC-27W-KIT-F	in preparation	LGB-AC-27W-KIT-F+LU1	in preparation
	G - Double seal, Scraper	LGB-AC-27W-KIT-G	in preparation	LGB-AC-27W-KIT-G+LU1	in preparation
LGB_35 T/W	B - Standard saling	-	-	LGB-AC-35W-KIT-B+LU1	in preparation
	E - Double seal	LGB-AC-35W-KIT-E	in preparation	LGB-AC-35W-KIT-E+LU1	in preparation
	F - Scraper	LGB-AC-35W-KIT-F	in preparation	LGB-AC-35W-KIT-F+LU1	in preparation
	G - Double seal, Scraper	LGB-AC-35W-KIT-G	in preparation	LGB-AC-35W-KIT-G+LU1	in preparation

6.1.3 Dimensions

The length L of the carriage varies according to the selected sealing option. The respective lengths are summarised in Table 6.3.

Table 6.3 Carriage length with sealing options [mm]

Type	SS	UU	AA	BB	EE	FF	GG	VV	WW
LGB_15 BS/FS	40,6	40,6	40,6	40,6	46,6	42,4	48,4	59,6	61,4
LGB_15 BN/FN	58,6	58,6	58,6	58,6	64,6	59,5	66,4	77,6	79,4
LGB_15 BL/FL	66,1	66,1	66,1	66,1	72,1	67,0	73,9	85,1	86,9
LGB_20 BS/FS	49,1	49,1	49,1	49,1	56,1	50,3	58,5	69,1	71,5
LGB_20 BN/FN	70,1	70,1	70,1	70,1	77,1	71,3	79,5	90,1	92,5
LGB_20 BL/FL	82,9	82,9	82,9	82,9	89,9	84,1	92,3	102,9	105,3
LGB_20 BE/FE	98,1	98,1	98,1	98,1	105,1	99,3	107,5	118,1	120,5
LGB_25 BS/FS	54,0	54,0	54,0	54,0	61,0	55,5	63,9	74,0	76,9
LGB_25 BN/FN	79,2	79,2	79,2	79,2	85,7	80,2	88,6	98,7	101,6
LGB_25 BL/FL	93,9	93,9	93,9	93,9	100,4	94,9	103,3	113,4	116,3
LGB_25 BE/FE	108,6	108,6	108,6	108,6	115,1	109,6	118,0	128,1	131,0
LGB_30 FS	64,2	64,2	64,2	64,2	72,2	65,5	74,8	90,2	92,8
LGB_30 BN/FN	94,8	94,8	94,8	94,8	102,8	96,1	105,4	120,8	123,4
LGB_30 BL/FL	105,0	105,0	105,0	105,0	113,0	106,3	115,6	131,0	133,6
LGB_30 BE/FE	130,5	130,5	130,5	130,5	138,5	131,8	141,1	156,5	159,1
LGB_35 FS	75,5	75,5	75,5	75,5	84,5	78,1	87,1	103,5	106,1
LGB_35 BN/FN	111,5	111,5	111,5	111,5	120,5	114,1	123,1	139,5	142,1
LGB_35 BL/FL	123,5	123,5	123,5	123,5	132,5	126,1	135,1	151,5	154,1
LGB_35 BE/FE	153,5	153,5	153,5	153,5	162,5	156,1	165,1	181,5	184,1
LGB_45 BN/FN	129,0	129,0	129,0	129,0	139,0	130,5	142,0	157,0	160,0
LGB_45 BL/FL	145,0	145,0	145,0	145,0	155,0	146,5	158,0	173,0	176,0
LGB_45 BE/FE	174,0	174,0	174,0	174,0	184,0	175,5	187,0	202,0	205,0
LGB_55 BN/FN	155,0	155,0	155,0	155,0	165,0	156,3	167,6	183,0	185,6
LGB_55 BL/FL	193,0	193,0	193,0	193,0	203,0	194,3	205,6	221,0	223,6
LGB_55 BE/FE	210,0	210,0	210,0	210,0	220,0	211,3	222,6	238,0	240,6
LGB_21 TN/WN	-	58,8	58,8	58,8	64,8	60,8	66,8	-	-
LGB_27 TN/WN	-	72,6	72,6	72,6	78,6	74,6	80,6	-	-
LGB_35 TN/WN	-	103,0	103,0	103,0	109,0	105,0	111,0	-	-
LGM_07BN	-	-	24,0	24,0	-	-	-	-	-
LGM_09BN	-	-	30,8	30,8	-	-	-	-	-
LGM_09BL	-	-	40,5	40,5	-	-	-	-	-
LGM_12BN	-	-	34,0	34,0	-	-	-	-	-
LGM_12BL	-	-	47,0	47,0	-	-	-	-	-
LGM_15BN	-	-	42,0	42,0	-	-	-	-	-
LGM_15BL	-	-	59,8	59,8	-	-	-	-	-
LGM_09WN	-	-	39,0	39,0	-	-	-	-	-
LGM_09WL	-	-	51,0	51,0	-	-	-	-	-
LGM_12WN	-	-	44,5	44,5	-	-	-	-	-
LGM_12WL	-	-	59,1	59,1	-	-	-	-	-
LGM_15WN	-	-	55,5	55,5	-	-	-	-	-
LGM_15WL	-	-	74,7	74,7	-	-	-	-	-

6.2 Rail caps

Foreign particles may reach the inside of the carriage through the fastening holes in the guide rail and cause damage. We recommend that you close the holes in the rail with rail caps to prevent this. These caps consist of oil-resistant plastic. Rail caps made of brass may be used when the pollution is very strong or when direct mechanical forces act on the guide rails. Table 6.4 contains an overview of the rail caps available.

Table 6.4 Rail caps

Size	Rail cap	Dimension [mm]		Rail cap	Dimension [mm]	
	Plastic	D	H	Brass	D	H
LGBR15	LG-CAP4	7,5	1,3	LG-CAP4B	7,5	2,5
LGBR20	LG-CAP5	9,5	2,5	LG-CAP5B	9,5	2,5
LGBR25	LG-CAP6	11,0	2,5	LG-CAP6B	11,0	2,5
LGBR30	LG-CAP8	14,0	3,5	LG-CAP8B	14,0	2,8
LGBR35	LG-CAP8	14,0	3,5	LG-CAP8B	14,0	2,8
LGBR45	LG-CAP12	20,0	3,5	LG-CAP12B	20,0	4,0
LGBR55	LG-CAP14	23,0	4,5	LG-CAP14B	23,0	4,0
LGBW21	LG-CAP4	7,5	1,3	LG-CAP4B	7,5	2,5
LGBW27	LG-CAP4	7,5	1,3	LG-CAP4B	7,5	2,5
LGBW35	LG-CAP6	11,0	2,5	LG-CAP6B	11,0	2,5
LGMR09	LG-CAP1	6,0	1,5	-	-	-
LGMR12	LG-CAP1	6,0	1,5	-	-	-
LGMR15	LG-CAP1	6,0	1,5	-	-	-
LGMW09	LG-CAP1	6,0	1,5	-	-	-
LGMW12	LG-CAP2	8,0	2,0	-	-	-
LGMW15	LG-CAP2	8,0	2,0	-	-	-

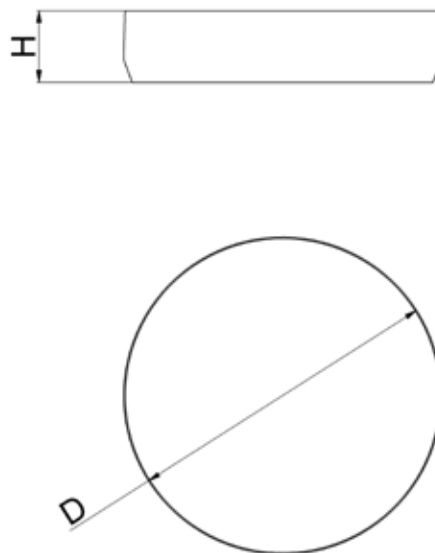

Figure 6.3 Rail caps

6.3 Bellows

If Linear Guides are exposed to strong contamination by chips, dust or welding spatter, it is recommended to protect the guides by special bellows. For SNR Linear Guides are the corresponding bellows available. The corresponding mounting sets can be used for the fixing of the bellows. The mounting sets consist of all necessary mounting screws, a distance element and a clamping element. With the clamping elements, the bellows are positioned and fixed on the rail. A special manufacturing of the rail is not necessary.

6.3.1 Dimensions

Table 6.5 Bellows

Size	Height [mm] A	Width [mm] B	Overall height [mm] A1	Depth of fold [mm] Ft	Relation of length R	Length per fold [mm] ApF	Stroke per fold [mm] HpF	Thickness mounting set [mm]	Recommended design type of carriage	Type bellow
15	26	46	29	15	8	20	17,5	5	LGB_H15F	LGB15-BEL-H...
20	32,5	61	37	20	10	30	27	5	LGB_H20F	LGB20-BEL-H...
25	33,5	66	39,5	20	10	30	27	5	LGB_H25F	LGB25-BEL-H...
30	37	70	44	20	10	30	27	6	LGB_H30F	LGB30-BEL-H...
35	39,5	78	47	20	10	30	27	6	LGB_H35F	LGB35-BEL-H...
45	44	85	53	20	10	30	27	8	all	LGB45-BEL-H...
55	50	97	62,5	20	10	30	27	8	all	LGB55-BEL-H...

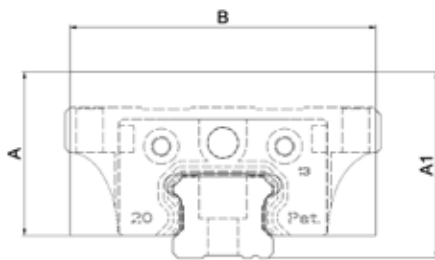

Figure 6.3 Dimensions of the bellows

Calculation of the bellow length:

Necessary quantity = Number of folds = Round up (Stroke / HpF) + 1 or Round off (Lmax / ApF) + 1

Lmin = Number of folds * 3mm (2,5 mm for size 15)

Type code bellow:

LGB30-BEL-H 105 / 1050 -35



Type code Mounting set:

LGB30-BEL-H-MS

6.3.2 Assembly of bellows

- Move the carriage (pos.2) to the rail end and disassemble the bottom head screws (pos.8) of the end seals.
- Assemble bellow (pos.5) with the spacer (pos.3) and the enclosed bottom head screws (pos.8) on the carriage.
- Assemble bellow on the clamping element (pos.4) with the bottom head screws (pos.7).
- Position the bellow with the assembled clamping element at the desired location.
- Fix the clamping element with the set screw (pos.6) on the rail.

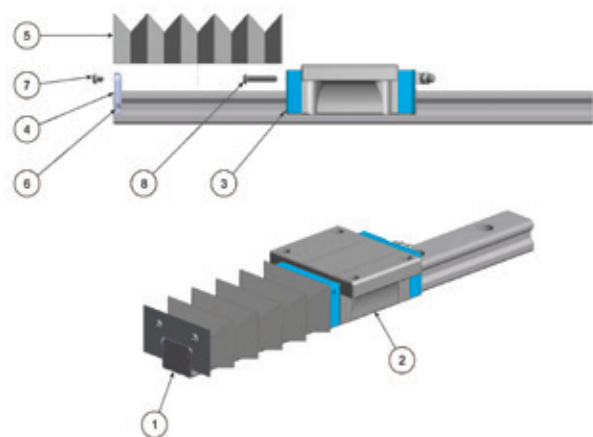

Figure 6.4 Assembly of bellows

6.3.3 Designation

The bellows for SNR Linear Guides and the related parts have the following designations:

- Bellow LGB[size] - BEL-H Lmin / Lmax - Number of folds
- Mounting set LGB[size] - BEL-H- MS

6.4 Cover strip

To close the rail holes, SNR Linear Guides can be assembled with a cover strip. In this case, the assembly time which is required to close the holes from long rails with plastic caps should be reduced considerably. The cover strip is a stainless steel strip, which is glued on top of the rails. Even under the most adverse environmental conditions, the adhesive bond is not affected. To secure the cover strip on the rail ends, corresponding securing elements are available. The standard cover strip is available in lengths up to 25 m.

6.4.1 Dimension

Table 6.6 Cover strip

Size	Width [mm]	Thickness [mm]	Length of safety element [mm]
LGBR15	10	0,3	12,5
LGBR20	11	0,3	12,5
LGBR25	13	0,3	12,5
LGBR30	16	0,3	12,5
LGBR35	18	0,3	14,2
LGBR45	27	0,3	17,5
LGBR55	29	0,3	17,5

6.4.2 Mounting tool

A mounting tool is available for the assembly of the cover strip. The use of the mounting tool ensures a simple, safe and centered mounting on top of rail.

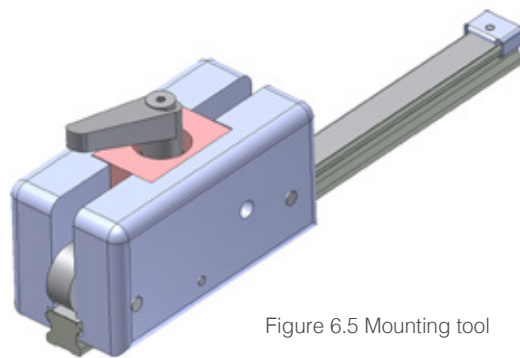

Figure 6.5 Mounting tool

6.4.3 Designation

The cover strip for SNR Linear Guides and the related parts have the following designations:

- Cover strip LGB[size]-CS [length in mm (five digits)]
- Safety element LGB[size]-SE
- Mounting tool LGB[size]-MT

6.5 Clamping and braking elements

Clamping and braking elements for SNR Linear Guides allow the positioning, holding and braking in different application areas.

6.5.1 Manual clamping element

Manual clamping elements are designed for up to 50,000 static clamping cycles.

The manual clamping elements for standard Linear Guides are actuated via a freely adjustable hand lever. In the process, the contact profiles press synchronously against the free surfaces of the rails. The floating contact profiles guarantee symmetrical force transmission to the Linear Guides. The dimensions are shown in Figure 6.6 and summarized in Table 6.7.

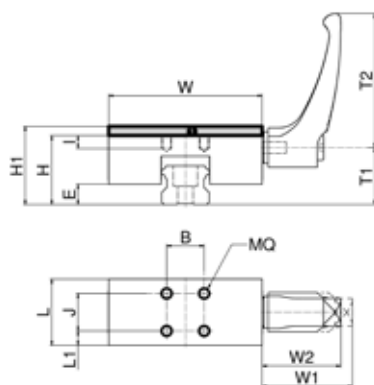

Figure 6.6 Manual clamping elements for Standard Linear Guides

① Adapting plate (accessories)

Table 6.7 Manual clamping elements for standard guides

Size	Carriage	Type	Adapter plate	Holding force [N]	Tightening torque [Nm]	Dimension [mm]														Mass [kg]
						W	L	H1	H	E	B	J	L1	MQ	I	W1	W2	T1	T2	
15	LGB_S15B	HK1501A	PHK15-2	1 200	5,0	47	25	24	22	4,5	17	17	4,0	M4	5	33,5	30,5	12,5	44	0,16
	LGB_S15F		PHK15-6					28												0,18
	LGB_H15F							28												0,26
	LGB_H15B		30					0,28												
20	LGB_S20B	HK2001A	-	1 200	7,0	60	24	28	28	8,0	15	15	4,5	M5	6	41,5	38,5	13,0	63	0,28
	LGB_S20F		PHK20-2					30												0,37
	LGB_H20F							33												0,42
	LGB_H20B		36					0,49												
25	LGB_S25B	HK2501A	-	1 200	7,0	70	30	33	33	9,0	20	20	5,0	M6	8	41,5	38,5	15,0	63	0,37
	LGB_S25F		PHK25-4					36												0,42
	LGB_H25F							40												0,49
	LGB_X25B		40					0,49												
30	LGB_S30B	HK3001A	-	2 000	15,0	90	39	42	42	12,0	22	22	8,5	M6	8	50,5	46,5	21,5	78	0,76
	LGB_H30F		PHK30-3					45												0,84
	LGB_H30B							45												0,84
35	LGB_S35B	H3501A	PMK35-4	2 000	15,0	100	39	48	44	12,0	24	24	7,5	M8	10	50,5	46,5	21,5	78	1,06
	LGB_H35F		PMK35-11					55												1,28
	LGB_H35B							55												1,28
45	LGB_S45B	HK4501A	PHK45-6	2 000	15,0	120	44	60	54	12,0	26	26	9,0	M10	14	50,5	46,5	26,5	78	1,65
	LGB_H45F		PHK45-12					70												1,90
	LGB_H45B							70												1,90
55	LGB_S55B	HK5501A	PHK55-4	2 000	17,0	140	49	70	66	17,0	30	30	9,5	M14	16	61,5	56,5	31,0	95	1,82
	LGB_H55F		PHK55-14					80												2,35
	LGB_H55B							80												2,35
21	LGBXH_T	HK2101B	-	1 200	7,0	77	24	21	21	3,0	24	15	4,5	M5	6	33,5	30,5	15,5	44	0,23
	LGBXH_W		21					0,23												
27	LGBXH_T	HK2701B	-	1 200	7,0	80	30	27	27	4,0	20	20	5,0	M6	6	33,5	30,5	21	44	0,30
	LGBXH_W		27					0,30												
35	LGBXH_T	HK3501B	-	2 000	15,0	135	39	35	35	4,0	50	20	9,5	M8	10	50,5	46,5	24,5	78	1,10
	LGBXH_W		35					1,10												

The manual clamping elements for miniature guides are actuated via clamping screw. In the process, the contact profiles press synchronously against the free surfaces of the rails. The floating contact profiles guarantee symmetrical force transmission to the Linear Guides. The dimensions are shown in Figure 6.7 and summarized in Table 6.8.

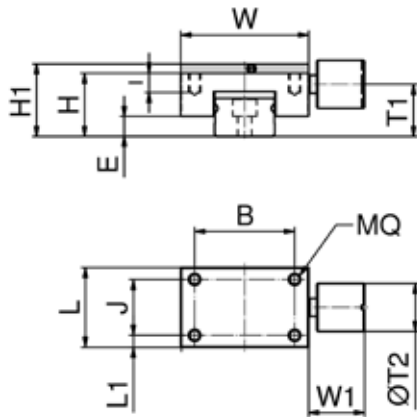

Figure 6.7 Manual clamping elements for miniature guides

① Adapting plate (accessories)

Table 6.8 Manual clamping elements for miniature guides

Size	Carriage	Type	Holding force [N]	Tightening torque [Nm]	Dimension [mm]													Mass [kg]
					W	L	H1	H	E	B	J	L1	MQ	I	W1	T1	T2	
07	LGM_09B	HK0700M	65	0,11	17	12	6	6	2,0	12	8	2,0	M2	2,5	7,0	6,3	6	0,01
09	LGM_09B	HK0900M	100	0,17	20	17	10	10	2,7	15	11	3,0	M3	3,0	9,0	8,1	8	0,02
	LGM_09W	HK0900MW	100	0,17	30	17	12	12	4,2	17	11	3,0	M3	3,0	9,0	10,1	8	0,03
12	LGM_12B	HK1200M	150	0,35	27	19	13	13	3,5	20	13	3,0	M3	3,6	10,0	10,7	10	0,03
	LGM_12W	HK1200MW	150	0,35	40	19	14	14	4,0	30	13	3,0	M3	3,6	10,0	11,7	10	0,06
15	LGM_15B	HK1500M	180	0,75	32	20	16	16	5,0	25	14	3,0	M3	4,0	14,0	13,1	12	0,05
	LGM_15W	HK1500MW	180	0,75	60	22	16	16	4,5	45	15	3,5	M3	4,0	14,7	13,1	12	0,10

6.5.2 Pneumatic clamping element

Pneumatic clamping elements are designed for up to 5 million static clamping cycles.

Pneumatic clamping elements are available in different designs as active (NO) and passive (NC) variants. Active variants are elements that close with pneumatic pressure, while passive variants close with spring energy storage. An integrated wedge gear realizes high holding forces. The pressure medium moves the wedge gear in the longitudinal direction. The resulting transverse movement presses the contact profiles against the free surfaces of the rails with high force. The dimensions of active elements are summarized in Figures 6.8 to 6.10 and Tables 6.9 to 6.11, the passive elements in Figures 6.11 to 6.13 and Tables 6.12 to 6.14.

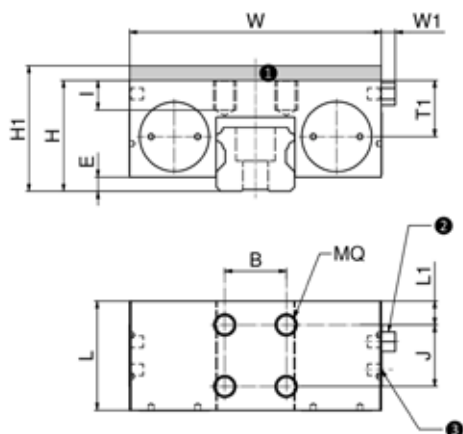

Figure 6.8 Active pneumatic clamping elements for Standard Linear Guides

- ① Adapter plate PMK (accessory)
- ② Air filter
- ③ Air connection M5

Table 6.9 Active pneumatic clamping elements for Standard Linear Guides

Size	Carriage	Type	Adapter plate	Holding force [N]	Dimension [mm]											Mass [kg]	
					W	L	H1	H	E	B	J	L1	MQ	I	W1		T1
15	LGB_S15B	MK1501A	-	650	55	39	24	24	2,5	15	15	15,5	M4	4,5	6	12,0	0,24
	LGB_S15F																
	LGB_H15F																
	LGB_H15B		PMK15-4				28										
20	LGB_S20B	MK2001A	-	1 000	66	39	28	28	2,5	20	20	5,0	M5	5,5	6	14,4	0,30
	LGB_S20F																
	LGB_H20F																
	LGB_H20B																
25	LGB_S25B	MK2501A	-	1 200	75	35	33	33	5,0	20	20	5,0	M6	8,0	5	15,5	0,34
	LGB_S25F																
	LGB_H25F		PMK25-2				36	34									0,37
	LGB_X20B		PMK25-6				40	0,44									
	LGB_H25B																
30	LGB_S30B	MK3001A	-	1 750	90	39	42	42	7,0	22	22	8,5	M8	10,0	5	20,5	0,61
	LGB_H30F		PMK30-3				45										0,69
	LGB_H30B																
35	LGB_S35B	MK3501A	PMK35-4	2 000	100	39	48	44	7,5	24	24	7,5	M8	10,0	5	20,5	0,69
	LGB_H35F		PMK35-11				55										1,03
	LGB_H35B																
45	LGB_S45B	MK4501A	PMK45-6	2 250	120	49	60	54	10,5	26	26	11,5	M10	15,0	5	26,8	1,55
	LGB_H45F		PMK45-16				70										1,96
	LGB_H45B																
55	LGB_S55B	MK5501A	PMK55-7	2 250	128	49	70	64	14,5	30	30	9,5	M10	18,0	5	30,5	1,98
	LGB_H55F		PMK55-17				80										2,52
	LGB_H55B																
	LGB_S55B																
21	LGBXH_T	MK2101B	-	650	77	49	21	21	2,0	15	15	12,5	M5	5,0	5	9,6	0,34
	LGBXH_W																
27	LGBXH_T	MK2701B	-	1 000	88	53	27	27	4,0	20	20	13,5	M6	6,0	5	11,5	0,45
	LGBXH_W																
35	LGBXH_T	MK3501B	-	1 200	121	36	35	35	5,0	50	20	11,0	M8	10,0	5	17,5	0,58
	LGBXH_W																

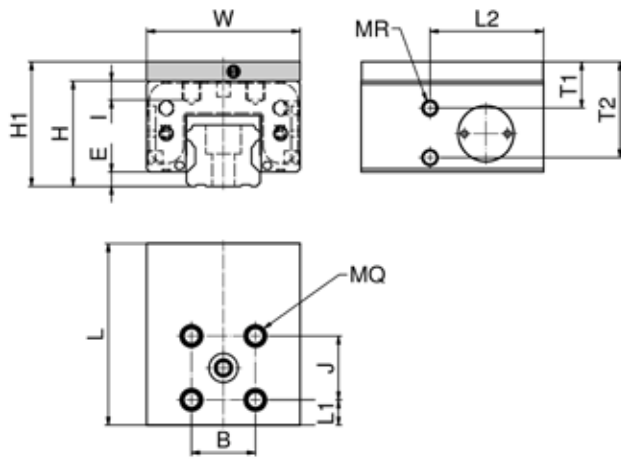

Figure 6.9 Compact active pneumatic clamping elements for Standard Linear Guides

- ❶ Adapter plate PLK (accessory)
- ❷ Air filter

Table 6.10 Compact active pneumatic clamping elements for Standard Linear Guides

Size	Carriage	Type	Adapter plate	Holding force [N]	Dimension [mm]													Mass [kg]		
					W	L	H1	H	E	B	J	L1	MQ	I	MR	L2	T1		T2	
15	LGB_S15B	LKP1501AS2	-	550	34	49	24	24	3,3	15	15	8,5	M4	4,5	M3	31,5	4,5	17,0	0,14	
	LGB_S15F																			
	LGB_H15F																			
	LGB_H15B		PLK15-4				28													0,19
20	LGB_S20B	LKP2001AS2-A	-	850	44	52,0	28	28	3,5	20	20	7,0	M5	5,5	M3	33,5	4,5	20,5	0,23	
	LGB_S20F																			
	LGB_H20F																			
	LGB_H20B		PLK20-2				30													0,26
25	LGB_S25B	LKP2501AS2-A	-	1 100	48	57,0	33	33	4,5	20	20	8,0	M6	6,0	M5	35,5	8,5	24,0	0,33	
	LGB_S25F																			
	LGB_H25F		PLK25-2				36													0,37
	LGB_X20B																			
25	LGB_H25B		PLK25-6			40													0,45	
	35	LGB_S35B	LKP3501AS2-A	2 500	70	68,5	48	48	7,5	24	24	7,5	M8	10,0	M5	41,5	7,5	33,5	0,78	
		LGB_H35F																		
LGB_H35B	PLK35-7	55					1,03													

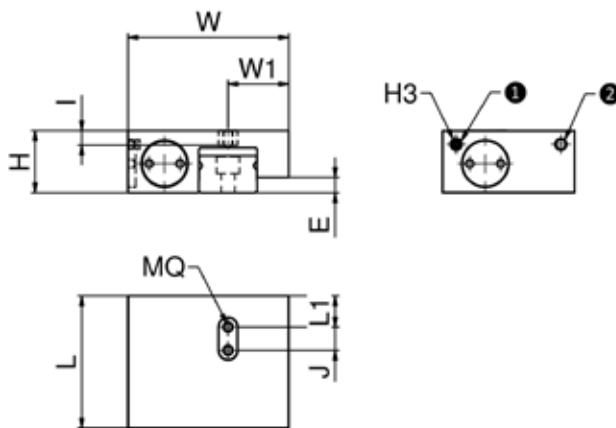

Figure 6.10 Active pneumatic clamping elements for Miniature guide

- ❶ Air filter
- ❷ Air connection M3

Table 6.11 Active pneumatic clamping elements for Miniature guide

Size	Carriage	Type	Holding force [N]	Dimension [mm]										Mass [kg]
				W	L	H	E	J	L1	MQ	I	W1	H3	
09	LGM_09B	MCP0901H	130	32,5	34	15	7,15	5,5	8,25	M2,5	3,3	9,7	M3	0,08
	LGM_09W	MCP0901HW	130	42,3	34	16	6,95	5,5	8,25	M2,5	3,5	15,0	M3	0,11
12	LGM_12B	MCP1201A	280	37,5	34	16	5,95	5,5	8,25	M2,5	3,5	13,2	M3	0,09
	LGM_12W	MCP1201HW	280	50,0	34	16	5,95	5,5	8,25	M2,5	3,5	19,7	M3	0,11
15	LGM_15B	MCP1501H	320	41,5	34	16	4,95	6,0	8,00	M2,5	3,8	15,7	M3	0,10
	LGM_15W	MCP1501HW	280	66,0	34	16	3,95	6,0	8,00	M2,5	3,8	28,7	M3	0,19

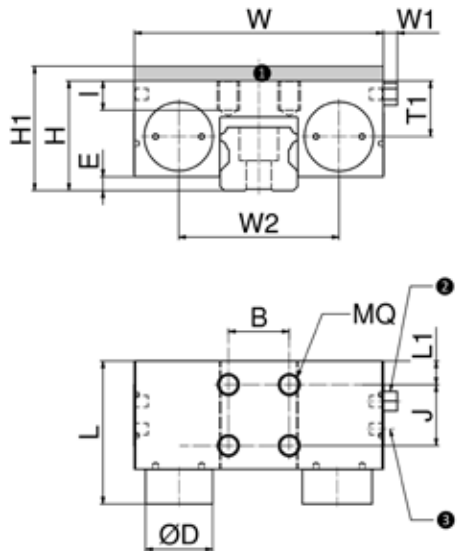

Figure 6.12 Passive pneumatic clamping elements for Standard Linear Guides

- ❶ Adapter plate PMK (accessory)
- ❷ Air connection M5
- ❸ Air filter or PLUS connection

Table 6.11 Passive pneumatic clamping elements for Standard Linear Guides

Size	Carriage	Type	Adapter plate	Holding force [N]	Dimension [mm]														Mass [kg]									
					W	L	H1	H	E	B	J	L1	MQ	I	W1	W2	T1	D										
15	LGB_S15B	MKS1501A	-	400	55	58	24	24	2,5	15	15	15,5	M4	4,5	6	34,0	12,0	16	0,26									
	LGB_S15F																											
	LGB_H15F		PMK15-4				28	30	4,5										20	20	5,0	M5	5,5	6	43,0	14,4	20	0,34
	LGB_H15B																											
20	LGB_S20B	MKS2001A	-	600	66	61	28	28	2,5	20	20	5,0	M5	5,5	6	43,0	14,4	20	0,34									
	LGB_S20F																											
	LGB_H20F		PMK25-2				30	30	4,5										20	20	5,0	M6	8,0	5	49,0	15,5	22	0,43
	LGB_H20B																											
25	LGB_S25B	MKS2501A	-	750	75	56	33	33	5,0	20	20	5,0	M6	8,0	5	49,0	15,5	22	0,40									
	LGB_S25F																											
	LGB_H25F		PMK25-6				36	34	6,0										20	20	5,0	M6	8,0	5	49,0	15,5	22	0,43
	LGB_X20B																											
LGB_H25B		40																0,50										
30	LGB_S30B	MKS3001A	-	1 050	90	68	42	42	7,0	22	22	8,5	M8	10,0	5	58,0	20,5	25	0,68									
	LGB_H30F																											
	LGB_H30B		PMK30-3				45																					
35	LGB_S35B	MKS3501A	PMK35-4	1 250	100	67	48	44	7,5	24	24	7,5	M8	10,0	5	68,0	20,5	28	0,92									
	LGB_H35F																											
	LGB_H35B		PMK35-11				55																					
45	LGB_S45B	MKS4501A	PMK45-6	1 450	120	82	60	54	10,5	26	26	11,5	M10	15,0	5	78,8	26,8	30	1,75									
	LGB_H45F																											
	LGB_H45B		PMK45-16				70																					
55	LGB_S55B	MKS5501A	PMK55-7	1 450	128	82	70	64	14,5	30	30	9,5	M10	18,0	5	87,0	30,5	30	2,18									
	LGB_H55F																											
	LGB_H55B		PMK55-17				80																					
21	LGBXH_T	MK2101B	-	400	77	58	21	21	2,0	15	15	12,5	M5	5,0	5	56,0	9,6	16	0,34									
	LGBXH_W																											
27	LGBXH_T	MK2701B	-	600	88	65	27	27	4,0	20,0	20	13,5	M6	6,0	5	65,0	11,5	20	0,44									
	LGBXH_W																											
35	LGBXH_T	MK3501B	-	750	121	57	35	35	5,0	50,0	20	11,0	M8	10,0	5	95,0	17,5	30	0,65									
	LGBXH_W																											

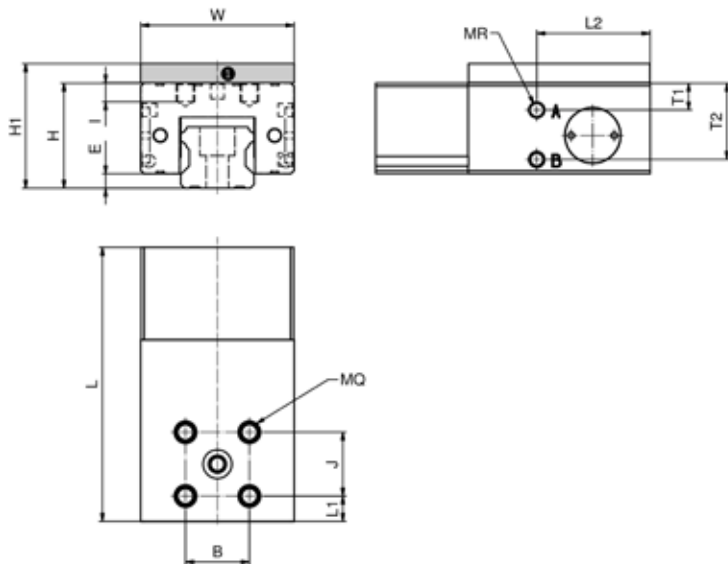

Figure 6.12 Compact passive pneumatic clamping elements for Standard Linear guides

- ① Adapter plate PLK (accessory)
- ② Air filter

Table 6.13 Compact passive pneumatic clamping elements for Standard Linear guides

Size	Carriage	Type	Adapter plate	Holding force [N]	Dimension [mm]														Mass [kg]	
					W	L	H1	H	E	B	J	L1	MQ	I	H3	L2	T1	T2		
15	LGB_S15B	LKPS1501AS2	-	400	34	76,0	24	24	3,3	15	15	8,5	M4	4,5	M3	31,5	4,5	17,0	0,18	
	LGB_S15F																			
	LGB_H15F																			
	LGB_H15B		PLK15-4				28													0,23
20	LGB_S20B	LKPS2001AS2-A	-	600	44	81,0	28	28	3,5	20	20	7,0	M5	5,5	M3	33,5	4,5	20,5	0,27	
	LGB_S20F																			
	LGB_H20F																			
	LGB_H20B		PLK20-2				30													0,30
25	LGB_S25B	LKPS2501AS2	-	750	48	86,0	33	33	4,5	20	20	8,0	M6	6,0	M5	35,5	8,5	24,0	0,41	
	LGB_S25F																			
	LGB_H25F		PLK25-2				36													0,45
	LGB_X20B																			
	LGB_H25B		PLK25-6				40													0,53

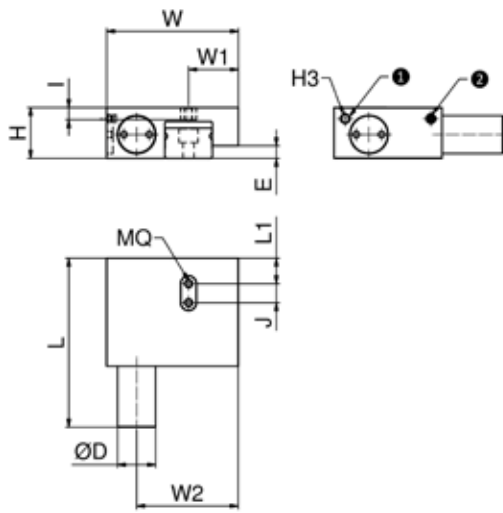

Figure 6.13 Passive pneumatic clamping elements for Miniature guides

- ① Air connection M3
- ② Air filter or PLUS connection M3

Table 6.14 Passive pneumatic clamping elements for Miniature guides

Size	Carriage	Type	Holding force [N]	Dimension [mm]											Mass [kg]	
				W	L	H	E	J	L1	MQ	I	W1	H3	D		W2
09	LGM_09B	MCPS0901H	80	32,5	52,5	10	7,15	5,5	8,25	M2,5	3,3	9,7	M3	12	23,05	0,08
	LGM_09W	MCPS0901HW	80	42,3	52,5	16	6,95	5,5	8,25	M2,5	3,5	15,0	M3	12	32,85	0,12
12	LGM_12B	MCPS1201A	250	37,5	52,5	13	5,95	5,5	8,25	M2,5	3,5	13,2	M3	12	28,05	0,10
	LGM_12W	MCPS1201HW	250	50,0	52,5	16	5,95	5,5	8,25	M2,5	3,5	19,7	M3	12	40,55	0,11
15	LGM_15B	MCPS1501H	280	41,5	52,5	16	4,95	6,0	8,00	M2,5	3,8	15,7	M3	12	32,05	0,11
	LGM_15W	MCPS1501HW	240	68,0	52,5	16	3,95	6,0	8,00	M2,5	3,8	28,7	M3	12	57,55	0,22

6.5.3 Pneumatic clamping and braking elements

Pneumatic clamping and braking elements are designed for up to 5 million static clamping cycles and 2,000 braking cycles.

Pneumatic clamping and braking elements are available in various designs as passive (NC) variants. These elements are closed with spring energy storage. An integrated wedge gear realizes high holding forces. The pressure medium moves the wedge gear in the longitudinal direction. The resulting transverse movement presses the contact profiles against the free surfaces of the rails with high force. The dimensions of these clamping and braking elements are summarized in Figures 6.14 to 6.16 and Tables 6.15 to 6.17.

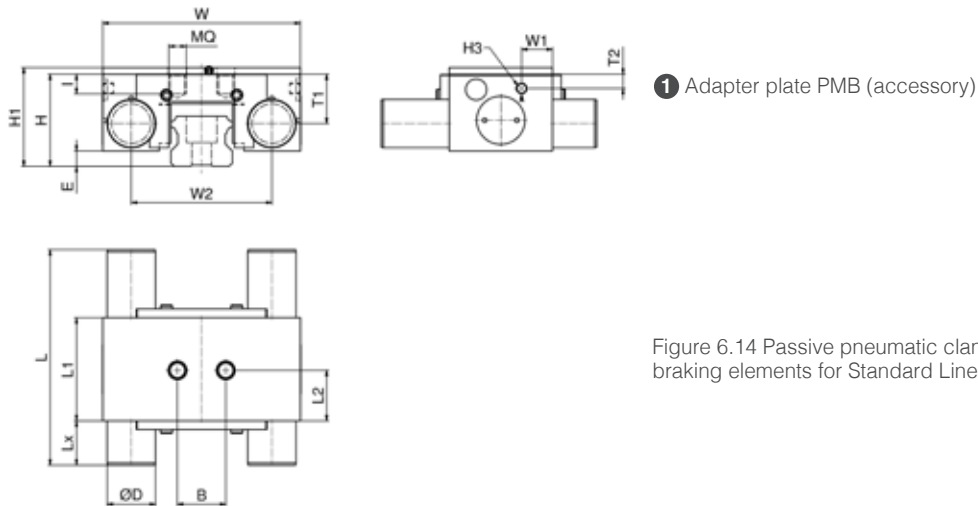

1 Adapter plate PMB (accessory)

Figure 6.14 Passive pneumatic clamping and braking elements for Standard Linear Guides

Table 6.15 Passive pneumatic clamping and braking elements for Standard Linear Guides

Size	Carriage	Type	Adapter plate	Holding force [N]	Dimension [mm]																Mass [kg]		
					W	L	H1	H	E	B	L1	L2	Lx	MQ	I	W1	W2	T1	T2	H3		D	
25	LGB_S25B	MBPS2510AS1	-	1 000	75	94,0	33	33	3,5	20	44,0	22,0	22,0	M6	8,0	16,2	52,0	18,0	5,0	M5	20	0,62	
	LGB_S25F		PMB25-2				36															0,67	
	LGB_H25F						PMB25-6															40	0,77
	LGB_X20B																						
LGB_H25B																							
35	LGB_S35B	MBPS3504BS1-A	PMB35-2	2 000	100	106,0	48	48	9,5	24	48,0	24,5	29,0	M8	9,0	19,0	70,4	34,7	7,5	M5	25	1,27	
	LGB_H35F		PMB35-9				55															1,52	
	LGB_H35B																						
45	LGB_S45B	MBPS4504BS1	PMB45-3	2 600	120	108,7	60	60	15	26	49,0	24,5	27,7	M10	14,0	16,0	88,0	29,5	8,0	G1/8	28	1,83	
	LGB_H45F		PMB45-13				70															2,26	
	LGB_H45B																						

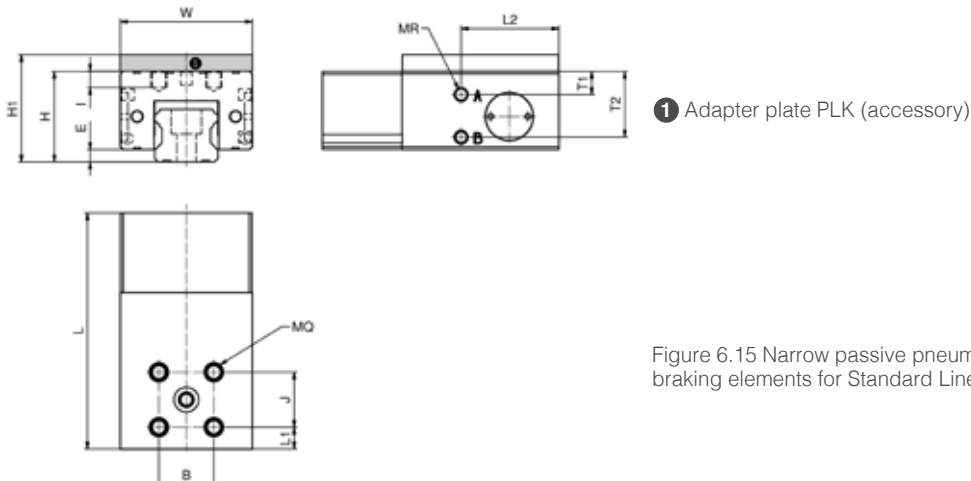

1 Adapter plate PLK (accessory)

Figure 6.15 Narrow passive pneumatic clamping and braking elements for Standard Linear Guides

6.5.4 Hydraulic clamping elements

Hydraulic clamping elements are designed for up to 10 million static clamping cycles.

Hydraulic clamping elements are available as active (NO) variants. Large-area contact profiles are pressed directly by the hydraulic oil against the free surfaces of the rails via a piston principle. A preloaded return spring ensures a short release cycle. The dimensions these clamping elements are summarized in Figure 6.17 and Table 6.18.

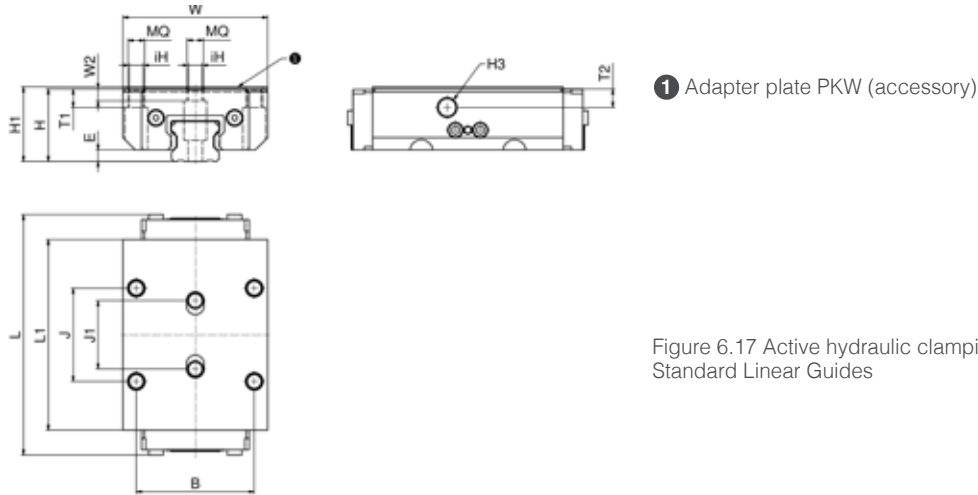

1 Adapter plate PKW (accessory)

Figure 6.17 Active hydraulic clamping elements for Standard Linear Guides

Table 6.18 Active hydraulic clamping elements for Standard Linear Guides

Size	Carriage	Type	Adapter plate	Holding force [N]	Dimension [mm]														Mass [kg]	
					W	L	H1	H	E	B	J	J1	L1	MQ	ih	W2	T1	T2		H3
35	LGB_S35B	KWH3514KS1A	-	5 700	100	145	48	48	8	82	62	62	120,5	M10	8,6	6,4	12	12,0	G1/8	2,70
	LGB_H35F		PKW35-7				55													3,33
	LGB_H35B																			
45	LGB_S45B	KWH4514KS1A	-	9 900	120	176	60	60	10	100	80	80	155,0	M12	10,5	11,9	15	15,0	G1/8	5,10
	LGB_H45F		PKW45-10				70													6,500
	LGB_H45B																			

6.6 Lubrication options

6.6.1 Lubrication system LU1

6.6.1.1 Structure

The lubrication system LU1 is developed for the use in combination with grease lubricated Linear Guides.

In operation, lubrication oil is given by capillary action to the raceways of the profile rail. The function is given in all mounting positions. With the continuous supply of oil, the operation interval of the lubricant inside of the carriage increases substantially.

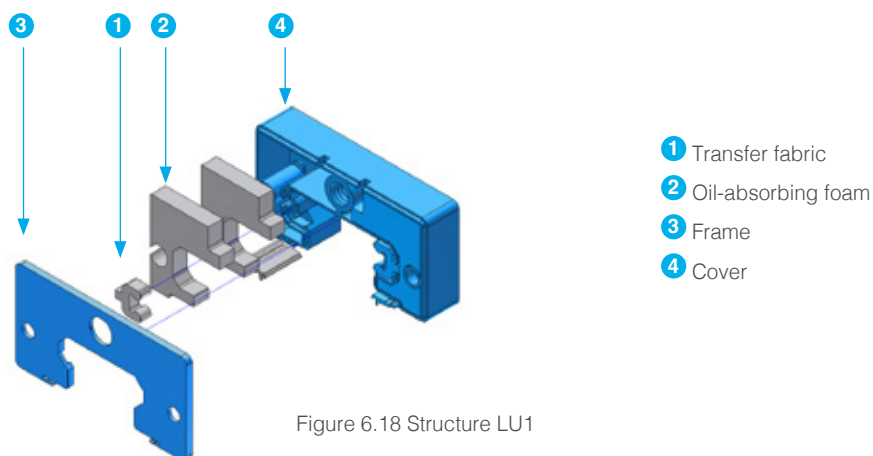

Figure 6.18 Structure LU1

The lubrication system LU1 (Figure 6.18) is split into two unconnected chambers. By default, the lubrication system LU1 is filled with the high-performance gear and multi-purpose oil Klübersynth® GEM 4 - 220. The combination of the lubrication system LU1 with all sealing options is possible.

6.6.1.2 Dimension

The dimension of the lubrication system LU1 are summarized in Figure 6.19 and Table 6.19.

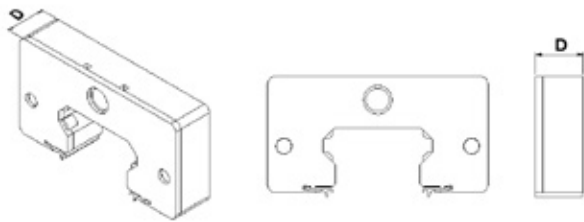

Figure 6.19 Dimensions LU1

Table 6.19

Size	Width D [mm]
LGB15-LU1	10,3
LGB20-LU1	10,3
LGB25-LU1	10,3
LGB30-LU1	10,3
LGB35-LU1	10,7
LGB45-LU1	13,0
LGB55-LU1	13,0
LGB21W-LU1	7,0
LGB27W-LU1	7,0
LGB35W-LU1	10,2

6.6.1.3 Features





The lubrication system LU1 is designed so that the grease nipples and lubrication connections for the re-lubrication of the carriage with grease can be directly mounted.

This lubrication oil is miscible with all of our standard greases. However, the greases SNR LUB FOOD and Klübersynth UH 14-151 lose their H1 – registration under this configuration. To refill the lubrication system under normal use is not necessary, but from the top of the cover it is possible. A sideways refill is not provided. Furthermore, the necessary holes could be manufactured by our production. Please contact in this case our application engineers. It is important that the two chambers of the lubrication system will always be refilled with oil. A filling with other lubrication oils according to customer specifications is possible. It is important that dynamic viscosity according DIN 51 562 T01 from approximately 200 mm²/s is given. Lower viscosity leads to more rapid emptying. Oils with higher viscosity could not be transported in extreme cases.

6.6.2 Lubrication connections

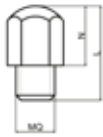
SNR Linear Guide carriages are supplied as standard with a grease nipple for face mounting. For all standard carriages, it is possible to mount various types of grease nipples, lubrication extensions, swivel connections or tube connections on the end plates on the front or side. Table 6.20 contains an overview of the available lubrication connections and Table 6.21 an assignment of the possible lubrication connections to the design types of the carriages.

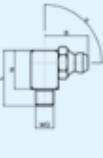
Table 6.20 Lubrication connections

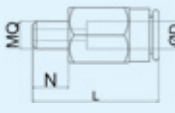
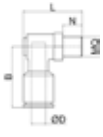
Type	Index number	ID Number	Designation	MQ	L [mm]	N (max.) [mm]	B [mm]	Mq	D [mm]	α [°]	SW
Grease nipple, ball type 	G01	355537	GRN-M3-3,5-z-0	M3	9,7	3,5	-	-	-	-	4
	G02	351752	GRN-M3-5,0-z-0	M3	13,0	5,0	-	-	-	-	4
	G03	351753	GRN-M3-8,0-z-0	M3	15,0	8,0	-	-	-	-	4
	G11	253132	GRN-M4-6,0-Z-0	M4	13,0	6,0	-	-	-	-	4
	G12	253133	GRN-M4-8,0-Z-0	M4	15,0	8,0	-	-	-	-	4
Grease nipple, hydraulic type 	G21	253082	GRN-M6-5,0-Z-0	M6	12,3	5,0	-	-	-	-	7
	G22	253110	GRN-M6-8,0-z-0	M6	15,3	8,0	-	-	-	-	7
	G23	253112	GRN-M6-12,0-z-0	M6	19,3	12,0	-	-	-	-	7
	G26	253134	GRN-M8-8,0-z-0	M8	18,2	12,0	-	-	-	-	9
	G27	253135	GRN-M8-12,0-z-0	M8	22,2	12,0	-	-	-	-	9
Grease nipple, hydraulic type 	G31	253121	GRN-M6-5,5-K-45	M6	23,5	18,0	10,5	-	-	45	9
	G32	253123	GRN-M6-8,0-K-45	M6	26,0	18,0	10,5	-	-	45	9
	G33	253125	GRN-M6-12,0-K-45	M6	30,0	18,0	10,5	-	-	45	9
	G41	258143	GRN-M6-5,0-Z-67	M6	18,5	13,5	11,4	-	-	67,5	9
	G42	253138	GRN-M6-8,0-Z-67	M6	21,5	13,5	11,4	-	-	67,5	9
	G43	253142	GRN-M6-12,0-Z-67	M6	25,5	13,5	11,4	-	-	67,5	9
	G46	253144	GRN-M8-8,0-Z-67	M8	21,3	13,3	12,3	-	-	67,5	9
	G47	253146	GRN-M8-12,0-Z-67	M8	25,3	13,3	12,3	-	-	67,5	9
Grease nipple, hydraulic type 	G51	253114	GRN-M6-5,5-K-90	M6	18,0	14,7	12,5	-	-	90	9
	G52	253117	GRN-M6-7,5-K-90	M6	20,0	14,7	12,5	-	-	90	9
	G53	253147	GRN-M6-12,0-Z-90	M6	24,5	14,7	12,5	-	-	90	9
	G56	253148	GRN-M8-8,0-Z-90	M8	20,5	13,0	12,5	-	-	90	9
	G57	253150	GRN-M8-12,0-Z-90	M8	24,5	13,0	12,5	-	-	90	9
Swivel connection 	S01	254337	LS-M6-M6	M6	29,5	8,0	17,0	M6	-	-	9
	S02	253126	LS-M6-M8x1	M6	29,5	8,0	17,0	M8x1	-	-	9
Tube connection, straight 	T01	474060	LH-M3x3,0A-4	M3	21,5	3,0	-	-	4	-	1,5 ¹
	T02	473990	LH-M3x4,5A-4	M3	21,5	4,5	-	-	4	-	1,5 ¹
	T06	244379	LH-M6x5A-4	M6	23,5	5,0	-	-	4	-	2,5 ¹
	T07	391765	LH-M6x8A-4	M6	23,5	8,0	-	-	4	-	2,5 ¹
	T08	244380	LH-M6x5A-6	M6	23,5	5,0	-	-	6	-	12
Tube connection, swiveling 	T11	270991	LH-M6x5S-4	M6	23,5	5,0	14,0	-	4	-	9
	T12	391762	LH-M6x8S-4	M6	23,5	8,0	14,0	-	4	-	9
	T13	262033	LH-M6x5S-6	M6	23,5	5,0	14,0	-	6	-	12
	T14	391759	LH-M6x8S-6	M6	23,5	8,0	14,0	-	6	-	12

1 Hexagon socket

Type	Index number	ID Number	Designation	MQ	L [mm]	N (max.) [mm]	B [mm]	Mq	D [mm]	α [°]	SW
	E01	316025	LE-M6-M6x15,4	M6	15,4	5,0	-	M6	-	-	10
	E02	250411	LE-M6-M6x18,4	M6	18,4	8,0	-	M6	-	-	10
	E03	250159	LE-M6-M6x22,4	M6	22,4	12,0	-	M6	-	-	10
	E04	250414	LE-M6-M8x15,4	M6	15,4	5,0	-	M8	-	-	10
	E05	250415	LE-M6-M8x18,4	M6	18,4	8,0	-	M8	-	-	10
	E06	250416	LE-M6-M8x22,4	M6	22,4	12,0	-	M8	-	-	10
	E07	250419	LE-M6-M8x1x15,4	M6	15,4	5,0	-	M8x1	-	-	10
	E08	250420	LE-M6-M8x1x18,4	M6	18,4	8,0	-	M8x1	-	-	10
	E09	250421	LE-M6-M8x1x22,4	M6	22,4	12,0	-	M8x1	-	-	10
	E10	250158	LE-M6-G1/8x15,4	M6	15,4	5,0	-	G1/8	-	-	12
	E11	250424	LE-M6-G1/8x18,4	M6	18,4	8,0	-	G1/8	-	-	12
	E12	250426	LE-M6-G1/8x22,4	M6	22,4	12,0	-	G1/8	-	-	12
	E21	250412	LE-M8-M6x18,4	M8	18,4	8,0	-	M6	-	-	10
	E22	250413	LE-M8-M6x22,4	M8	22,4	12,0	-	M6	-	-	10
	E23	250417	LE-M8-M8x18,4	M8	18,4	8,0	-	M8	-	-	10
	E24	250418	LE-M8-M8x22,4	M8	22,4	12,0	-	M8	-	-	10
	E25	250422	LE-M8-M8x1x18,4	M8	18,4	8,0	-	M8x1	-	-	10
	E26	250423	LE-M8-M8x1x22,4	M8	22,4	12,0	-	M8x1	-	-	10
	E27	250427	LE-M8-G1/8x18,4	M8	18,4	8,0	-	G1/8	-	-	12
	E28	250428	LE-M8-G1/8x22,4	M8	22,4	12,0	-	G1/8	-	-	12

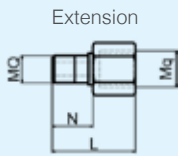

1 Hexagon socket

Table 6.21 Assignment of the lubrication connections

Type	Lubrication connection	lateral ³	Front side									
			Sealing option without lubrication system LU1				Sealing option with lubrication system LU1 ¹					
			AA, BB, UU, SS, FF	EE, GG	VV ²	WW ²	AA, BB, UU, SS, FF	EE, GG	VV	WW		
LGB_15 B_/F_	Grease nipple 0°	G01	G02 ²	G03	G11	G11	G11	G12	G11	G11		
	Tube connection, straight 4mm	T01	T02	-	T02	T02	-	-	-	-		
LGB_20 B_/F_	Grease nipple	0°	G21	G21	G22	G22	G22	G22	G22	G22	G22	
		45°	-	G31	G32	G32	G32	G32	G32	G32	G32	
		67°	-	G41 ²	G42	G42	G42	G42	G42	G42	G42	
		90°	-	G51	G52	G52	G52	G52	G52	G52	G52	
	Swivel connection	M6	-	-	-	S01	S01	S01	-	S01	S01	
		M8	-	-	-	S02	S02	S02	-	S02	S02	
	Tube connection, straight	4mm	-	T07	T07	T07	T07	T07	T07	T07	T07	
		6mm	-	T09	T09	T09	T09	T09	T09	T09	T09	
	Tube connection, swiveling	4mm	-	T12	T12	T12	T12	T12	T12	T12	T12	
		6mm	-	T14	T14	T14	T14	T14	T14	T14	T14	
	Extension	M6	-	E01	E03	E02	E02	E02	E02	E02	E02	
		M8	-	E04	E06	E05	E05	E05	E05	E05	E05	
		M8x1	-	E07	E09	E08	E08	E08	E08	E08	E08	
		G1/8"	-	E10	E12	E11	E11	E11	E11	E11	E11	
	LGB_25 B_/F_	Grease nipple	0°	G21	G21	G22	G22	G22	G22	G23	G22	G22
			45°	G31	G31	G32	G32	G32	G32	G33	G32	G32
67°			G41	G41 ²	G42	G42	G42	G42	G43	G42	G42	
90°			G51	G51	G52	G52	G52	G52	G53	G52	G52	
Swivel connection		M6	-	-	-	S01	S01	S01	S01	S01	S01	
		M8	-	-	-	S02	S02	S02	S02	S02	S02	
Tube connection, straight		4mm	T06	T07	-	T07	T07	T07	-	T07	T07	
		6mm	-	T09	-	T09	T09	T09	-	T09	T09	
Tube connection, swiveling		4mm	T11	T12	-	T12	T12	T12	-	T12	T12	
		6mm	-	T14	-	T14	T14	T14	-	T14	T14	
Extension		M6	-	E01	E03	E02	E02	E02	E02	E02	E02	
		M8	-	E04	E06	E05	E05	E05	E05	E05	E05	
		M8x1	-	E07	E09	E08	E08	E08	E08	E08	E08	
		G1/8"	-	E10	E12	E11	E11	E11	E11	E11	E11	
LGB_30 B_/F_		Grease nipple	0°	G21	G22	G23	G22	G22	G22	G23	G22	G22
			45°	G31	G32	G33	G32	G32	G32	G33	G32	G32
	67°		G41	G42 ²	G43	G42	G42	G42	G43	G42	G42	
	90°		G51	G52	G53	G52	G52	G52	G53	G52	G52	
	Swivel connection	M6	-	-	-	S01	S01	S01	-	S01	S01	
		M8	-	-	-	S02	S02	S02	-	S02	S02	
	Tube connection, straight	4mm	T06	T07	-	T07	T07	T07	-	T07	T07	
		6mm	T08	T09	-	T09	T09	T09	-	T09	T09	
	Tube connection, swiveling	4mm	T11	T12	-	T12	T12	T12	-	T12	T12	
		6mm	T13	T14	-	T14	T14	T14	-	T14	T14	
	Extension	M6	-	E01	E03	E02	E02	E02	E03	E02	E02	
		M8	-	E04	E06	E05	E05	E05	E06	E05	E05	
		M8x1	-	E07	E09	E08	E08	E08	E09	E08	E08	
		G1/8"	-	E10	E12	E11	E11	E11	E12	E11	E11	

¹ additional tube seal necessary

² Standard grease nipples

³ for flange type carriages, can only be mounted at the factory

Type	Lubrication connection	lateral ³	Front side									
			Sealing option without lubrication system LU1				Sealing option with lubrication system LU1 ¹					
			AA, BB, UU, SS, FF	EE, GG	VV	WW	AA, BB, UU, SS, FF	EE, GG	VV	WW		
LGB_35 B_/F_	Grease nipple	0°	G21	G22	G23	G22	G22	G22	G22	G23	G22	G22
		45°	G31	G32	G33	G32	G32	G32	G32	G33	G32	G32
		67°	G41	G42 ²	G43	G42	G42	G42	G42	G43	G42	G42
		90°	G51	G52	G53	G52	G52	G52	G52	G53	G52	G52
	Swivel connection	M6	-	-	-	S01	S01	S01	S01	-	S01	S01
		M8	-	-	-	S02	S02	S02	S02	-	S02	S02
	Tube connection, straight	4mm	T06	T07	-	T07	T07	T07	T07	-	T07	T07
		6mm	T08	T09	-	T09	T09	T09	T09	-	T09	T09
	Tube connection, swiveling	4mm	T11	T12	-	T12	T12	T12	T12	-	T12	T12
		6mm	T13	T14	-	T14	T14	T14	T14	-	T14	T14
	Extension	M6	-	E01	E03	E02	E02	E02	E02	E03	E02	E02
		M8	-	E04	E06	E05	E05	E05	E05	E06	E05	E05
		M8x1	-	E07	E09	E08	E08	E08	E08	E09	E08	E08
		G1/8"	-	E10	E12	E11	E11	E11	E11	E12	E11	E11
LGB_45 B_/F_	Grease nipple	0°	G26	G26	G27	G26	G26	G26	G26	G27	G26	G26
		67°	G46	G46 ²	G47	G46	G46	G46	G46	G47	G46	G46
		90°	G56	G56	G57	G56	G56	G56	G56	G57	G56	G56
	Extension	M6	-	E21	E22	E21	E21	E21	E21	E22	E21	E21
		M8	-	E23	E24	E23	E23	E23	E23	E24	E23	E23
		M8x1	-	E25	E26	E25	E25	E25	E25	E26	E25	E25
		G1/8"	-	E27	E28	E27	E27	E27	E27	E28	E27	E27
		G1/8"	-	E27	E28	E27	E27	E27	E27	E28	E27	E27
LGB_55 B_/F_	Grease nipple	0°	G26	G26	G27	G26	G26	G26	G26	G27	G26	G26
		67°	G46	G46 ²	G47	G46	G46	G46	G46	G47	G46	G46
		90°	G56	G56	G57	G56	G56	G56	G56	G57	G56	G56
	Extension	M6	-	E21	E22	E21	E21	E21	E21	E22	E21	E21
		M8	-	E23	E24	E23	E23	E23	E23	E24	E23	E23
		M8x1	-	E25	E26	E25	E25	E25	E25	E26	E25	E25
		G1/8"	-	E27	E28	E27	E27	E27	E27	E28	E27	E27
		G1/8"	-	E27	E28	E27	E27	E27	E27	E28	E27	E27
LGBXH21 T_/W_	Grease nipple	0°	G03	G21	G22	-	-	G23	G23	-	-	
		45°	-	G31	G32	-	-	G33	G33	-	-	
		67°	-	G41 ²	G42	-	-	G43	G43	-	-	
		90°	-	G51	G52	-	-	G53	G53	-	-	
	Swivel connection	M6	-	-	-	-	-	-	-	-	-	-
		M8	-	-	-	-	-	-	-	-	-	-
	Tube connection, straight	4mm	T02	T06	T07	-	-	-	-	-	-	-
		6mm	-	T08	T09	-	-	-	-	-	-	-
	Tube connection, swiveling	4mm	-	T12	-	-	-	-	-	-	-	-
		6mm	-	T14	-	-	-	-	-	-	-	-
	Extension	M6	-	E01	E01	-	-	-	-	-	-	-
		M8	-	E04	E04	-	-	-	-	-	-	-
		M8x1	-	E07	E07	-	-	-	-	-	-	-
		G1/8"	-	E10	E10	-	-	-	-	-	-	-

¹ additional tube seal necessary

² Standard grease nipples

³ for flange type carriers, can only be mounted at the factory

Type	Lubrication connection	lateral ³	Front side									
			Sealing option without lubrication system LU1				Sealing option with lubrication system LU1 ¹					
			AA, BB, UU, SS, FF	EE, GG	VV ¹	WW ¹	AA, BB, UU, SS, FF	EE, GG	VV	WW		
LGBXH27 T_W_	Grease nipple	0°	G03	G21	G22	-	-	G23	G23	-	-	
		45°	-	G31	G32	-	-	G33	G33	-	-	
		67°	-	G41 ²	G42	-	-	G43	G43	-	-	
		90°	-	G51	G52	-	-	G53	G53	-	-	
	Swivel connection	M6	-	S01	-	-	-	-	-	-	-	
		M8	-	S02	-	-	-	-	-	-	-	
	Tube connection, straight	4mm	T02	T06	T07	-	-	-	-	-	-	
		6mm	-	T08	T09	-	-	-	-	-	-	
	Tube connection, swiveling	4mm	-	T11	-	-	-	-	-	-	-	
		6mm	-	T13	-	-	-	-	-	-	-	
	Extension	M6	-	E01	E01	-	-	-	-	-	-	
		M8	-	E04	E04	-	-	-	-	-	-	
		M8x1	-	E07	E07	-	-	-	-	-	-	
		G1/8"	-	E10	E10	-	-	-	-	-	-	
	LGBXH35 T_W_	Grease nipple	0°	G21	G21	G22	-	-	G23	G23	-	-
			45°	G31	G31	G32	-	-	G33	G33	-	-
67°			G41	G41 ²	G42	-	-	G43	G43	-	-	
90°			G51	G51	G52	-	-	G53	G53	-	-	
Swivel connection		M6	-	-	-	-	-	-	-	-	-	
		M8	-	-	-	-	-	-	-	-	-	
Tube connection, straight		4mm	T06	T07	-	-	-	-	-	-	-	
		6mm	-	T09	-	-	-	-	-	-	-	
Tube connection, swiveling		4mm	T11	T12	-	-	-	-	-	-	-	
		6mm	-	T14	-	-	-	-	-	-	-	
Extension		M6	-	E01	E03	-	-	-	-	-	-	
		M8	-	E04	E06	-	-	-	-	-	-	
		M8x1	-	E07	E09	-	-	-	-	-	-	
		G1/8"	-	E10	E12	-	-	-	-	-	-	
LGM_15 B_W_		Grease nipple	0°	-	G02	-	-	-	-	-	-	

¹ additional tube seal necessary

² Standard grease nipples

³ for flange type carriages, can only be mounted at the factory

6.6.3 Lubrication adapter

The carriage of SNR Linear Guides are also prepared for the lubrication from the top of the end plates (Figure 6.20). For this purpose, the marked lubrication hole in the lowering must be opened. For this re-lubrication version, O-rings and adapters are necessary for height adjustment. Table 6.22 shows the necessary lubrication adapter and O-rings.

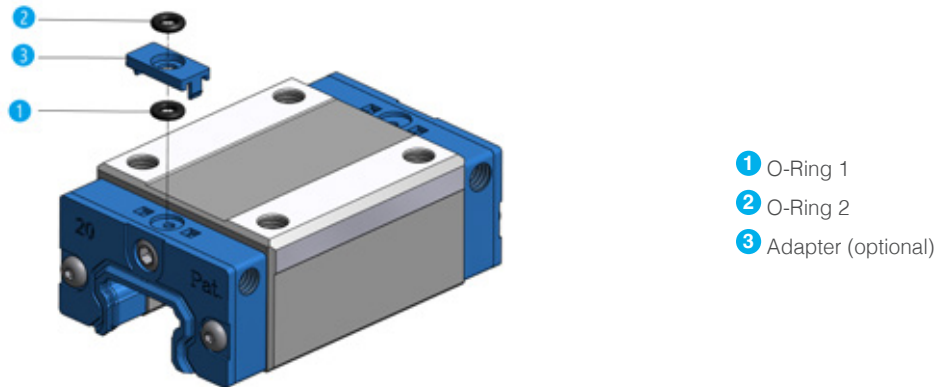

Figure 6.20 Lubrication adapter

Table 6.22 Lubrication adapter

Series	Design type	Size	Lubrication adapter	O-Ring 1	O-Ring 2
LGB_H	F	15	-	ORI3X1NBR70	-
		20	LA-02	ORI3X1,5NBR70	ORI3X1,5NBR70
		25	LA-03	ORI5X1,5NBR70	ORI3X1,5NBR70
		30	-	ORI6X1,5NBR70	-
		35	-	ORI6X1,5NBR70	-
		45	-	ORI10x2NBR70	-
		55	-	ORI10x2NBR70	-
	B	15	LA-04	ORI3X1NBR70	ORI3X1NBR70
		20	LA-02	ORI3X1,5NBR70	ORI3X1,5NBR70
		25	LA-07	ORI5X1,5NBR70	ORI3X1,5NBR70
		30	LA-03	ORI6X1,5NBR70	ORI3X1,5NBR70
		35	LA-07	ORI6X1,5NBR70	ORI3X1,5NBR70
		45	LA-10	ORI10x2NBR70	ORI10x2NBR70
		55	LA-10	ORI10x2NBR70	ORI10x2NBR70
	T	21	-	ORI4X1,5NBR70	-
		27	-	ORI4X1,5NBR70	-
		35	-	ORI4X1,5NBR70	-
	W	21	-	ORI4X1,5NBR70	-
		27	-	ORI4X1,5NBR70	-
		35	-	ORI4X1,5NBR70	-
	LGB_X	B	25	LA-03	ORI5X1,5NBR70
LGB_S	F	15	-	ORI3X1NBR70	-
		20	-	ORI3X1,5NBR70	-
		25	-	ORI5X1,5NBR70	-
	B	15	-	ORI3X1NBR70	-
		20	-	ORI3X1,5NBR70	-
		25	-	ORI5X1,5NBR70	-
		30	-	ORI6X1,5NBR70	-
		35	-	ORI6X1,5NBR70	-
		45	-	ORI10x2NBR70	-
		55	-	ORI10x2NBR70	-

6.6.4 Grease guns

SNR Linear Guides can be re-lubrication manually with grease guns.

For Miniature guides and Standard Linear Guides of size 15 and lateral lubrication points of the wide Standard Linear Guides of sizes 21 and 27 with ball type grease nipples, a push type grease gun with special adapter (LG-AC-LUB-KIT-B, ID number 631273) can be used (Figure 6.21).

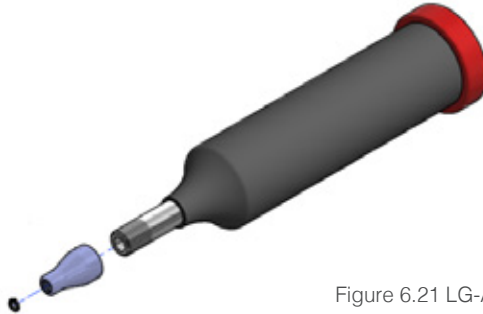

Figure 6.21 LG-AC-LUB-KIT-B

Technical data:

- Weight: 65 g
- Operating pressure: 80...120 bar
- Filling volume: 60 cm³
- Transported volume: 0,6 cm³/stroke

All Standard Linear Guides from size 20 with hydraulic type grease nipples can be re-lubricated with the SNR hand grease gun (LUB GREASE GUN SET, ID number 273018) (Figure 6.22). The LUB GREASE GUN SET includes the hand grease gun, a flexible hose and a adapter for hydraulic type grease nipples. The hand grease gun can be operated with one hand. It can take 400 g cartridges or directly unpacked grease.



Figure 6.22 LUB GREASE GUN SET

Technical data:

- Weight: 1.350 g
- Operating pressure: 180 bar
- Maximum pressure: 360 bar
- Transported volume: 0,5 cm³/stroke

6.6.5 Central lubrication systems

SNR Linear Guides can be connected to a central lubrication system.

Suitable central lubrication systems are SNR-LUBER-CONTROL (Figure 6.23) and SNR-POLYPUMP (Figure 6.24).

SNR-LUBER-CONTROL has six connections for lubrication tubes that can be parameterized individually. Optionally, CONTROL REFILL units with 250 cm³ and 500 cm³ lubricant volume can be used. The CONTROL REFILL unit can be exchanged after emptying or refilled factory provided.

SNR-POLYPUMP is a powerful central lubrication system that is easy to set up. It enables to lubricate 1 to 35 lubrication points at the same time in the simplest possible way. Various lubrication points can be supplied with different amounts of a lubricant with one system via pump elements. The storage container can easily be filled with standard refill cartridges. The connection to the existing machine control is quick and easy.



Figure 6.23 SNR-LUBER-CONTROL



Figure 6.24 SNR-POLYPUMP

7 Corrosion protection

SNR Linear Guides can be provided in the following versions when special requirements for corrosion protection apply:

Black chrome coating

- Oxide ceramic layer
- Thickness 2...10 µm
- No deformation of the parts
- Resistant to acids, alkalis and solvents
- Relatively soft layer (up to 350 HV), which clears away by rolling over in the area of the raceways
- Color: matt black
- Suitable for applications in the optic industry, medical industry,...

Hard chrome coating

- Galvanic process
- Thickness 2...5 µm
- No deformation of the parts
- Very high hardness of the layer (700...800 HV), good corrosion resistant
- Color: metallic blank
- Suitable for applications in clean rooms, food industry,...

DURALLOY® TDC coating

- Specific thin chrome coating
- Thickness 2,5...4 µm
- No deformation of the parts
- Crack free layer with extreme high hardness (800...1300 HV), very good corrosion resistant
- Color: matt grey
- Suitable for applications in wet areas

We recommend contacting our application engineers to select a suitable corrosion protection.

8 Type code

Type code examples for standard guides without options:

Linear Guide:

LGB C H 25 B N 2 SS L 01600 N Z1 - 2 - 0 -20,-.0 N
 1 2 3 4 5 6 7 8 9 10 11 12 13 14 15 16

Profile rail:

LGB R 25 L 01600 N - 2 - 0 -20.0 N
 1 2 4 9 10 11 13 14 15 16

Carriage:

LGB C H 25 B N SS N Z1 - N
 1 2 3 4 5 6 8 11 12 16

1	LGB	Series LGB: Standard Linear Guide LGM: Miniature guide
2	C	Version C: Carriage with ball chain W: Profile rail, wide X: Conventional carriage R: Profile rail, narrow
3	H	Design height* H: normal design height X: medium design height S: flat design height * does not apply for miniature guides
4	25	Design size
5	B	Design type of carriage B: Carriage, block design F: Carriage, flange design W: Wide carriage, block design T: Wide carriage, flange design
6	N	Length of the carriage S: Carriage, short N: Carriage, standard length L: Carriage, long E: Carriage extra long
7	2	Number of carriages
8	N	Seals SS: Inner, end and side seals (standard seal) BB: End and side seals EE: Inner, double-end and side seals GG: Inner, double-end and side seals and metal scrapers Additional sealing options see Chapter 6.1.2
9	L	Fastening method for the rail L: Rail with through-holes C: Rail with thread from below
10	01600	Rail length 5-digit specification in [mm]
11	N	Precision N: Normal precision H: H - Precision P: P - Precision S: Super - Precision U: Ultra - Precision
12	Z1	Perload class Z0: No perload Z1: Low preload Z2: Medium preload Z3: High preload ZX: Special preload
13	2	Rail arrangement 1: No information concerning rail arrangement 2: Two rails in parallel 3: Three rails in parallel 4: Four connected rails
14	0	Profile rail segmentation 0: One-segment rail 1: Rail with arbitrary segments 2: Rail segmentation according to drawing
15	20.0	Starting measure G1 of the rail Definition see Chapter 5.17
16	N	Special version of the Linear Guide N: Standard S: Special version, index follows

Type code example for standard guides with options:

Linear Guide:

LGB C H 25 B N 2 SS L 01600 N Z1 - 2 - 0 -20,-0 S E 02 2 - - 3 -
 1 2 3 4 5 6 7 8 9 10 11 12 13 14 15 16 17 18 19 20 21 22

Profile rail:

LGB R 25 L 01600 N 2 - 0 -20.0 S- 2 -
 1 2 4 9 10 11 13 14 15 16 21 22

Carriage:

LGB C H 25 B N SS N Z1 - S- E 02 2 -
 1 2 3 4 5 6 8 11 12 16 17 18 19 20

17...22		Index for special versions
17	E	Lubrication greases see Table 8.2 and Chapter 4.2.4
18	02	Lubrication connections see Table 8.1 and Chapter 4.4.1, 4.4.2
19	2	Material / coatings of the carriages see Table 8.3 and Chapter 6
20	-	Special versions of the carriages 0: Standard _: Index (A...Z) is given in a case of order
21	2	Material / coatings of the rails see Table 8.3 and Chapter 6
22	-	Special version of the rails 0: Standard _: Index (A...Z) is given in a case of order

Type code for Linear Guide Systems

Example:

LGS - 3 - LGB30 L01600 - LGB30 C01240 - LGB30 L01600 - 0
 1 2 3 4 5 6 7 8 9

Consisting of: 10

1. Linear Guide LGBCH30BN3SSL01600NZ1-3-0-20.0N
2. Linear Guide LGBCH30BN2SSC01240NZ1-3-0-20.0N
3. Linear Guide LGBCH30BN3SSL01600NZ1-3-0-20.0N

1	LGS	Linear Guide System
2	3	Rail arrangement
3	LGB30	Type of the first Linear Guide
4	L01600	Rail version and length of the first Linear Guide
5	LGB30	Type of the second Linear Guide
6	C01240	Rail version and length of the second Linear Guide
7	LGB30	Type of the third Linear Guide
8	L01600	Rail version and length of the third Linear Guide
9	0	Special version 0 : without special options A...Z : According to drawing or text description (Index (A...Z) is given from us)
10	Listing of type codes and description of all individual components

Table 8.1 Index of lubrication connections

Lubrication connections (s. Chapter 6.6.2)	Index	Miniature guides							Standard Linear Guides																					
		LGM_							LGB_																					
		07B_	09B_	12B_	15B_	09W_	12W_	15W_	15B_	20B_	25B_	30B_	35B_	45B_	55B_	15F_	20F_	25F_	30F_	35F_	45F_	55F_	21W_	27W_	35W_	21T_	27T_	35T_		
Front side grease nipple 67°	00							S								S	S	S	S	S	S	S	S	S	S	S	S	S		
Front side 2 set screws	01				x			x	x	x	x	x	x	x	x	x	x	x	x	x	x	x	x	x	x	x	x	x		
Front side grease nipple 0°	02				S			S	S	x	x	x	x	x	x	S	x	x	x	x	x	x	x	x	x	x	x	x		
Front side grease nipple 45°	03									x	x	x	x	x	x		x	x	x	x	x	x	x	x	x	x	x	x		
Front side grease nipple 90°	04									x	x	x	x	x	x		x	x	x	x	x	x	x	x	x	x	x	x		
Front side extension 0°	05									x	x	x	x	x	x		x	x	x	x	x	x	x	x	x	x	x	x		
Front side swivel connection	06									(x)	(x)	(x)	(x)			(x)	(x)	(x)	(x)											
Front side tube connection 0°	07									x	x	x	x	x		x	x	x	x	x				x	x	x	x	x		
Front side tube connection 90°	08									x	x	x	x				x	x	x	x				x	x	x	x	x		
Front side lubrication hole	09	S	S	S		S	S																							
Lateral on reference side grease nipple 67°	10										x	x	x	x	x		(x)	(x)	(x)	(x)	(x)	(x)			x		(x)			
Lateral on reference side grease nipple 0°	12									x	x	x	x	x	x	x	(x)	(x)	(x)	(x)	(x)	(x)	(x)	x	x	x	(x)	(x)	(x)	
Lateral on reference side grease nipple 45°	13										x	x	x	x	x		(x)	(x)	(x)	(x)	(x)	(x)			x		(x)	(x)		
Lateral on reference side grease nipple 90°	14										x	x	x	x	x		(x)	(x)	(x)	(x)	(x)	(x)			x		(x)	(x)		
Lateral on reference side tube connection 0°	17									x	x	x	x			x	(x)	(x)	(x)					x	x	x	(x)	(x)	(x)	
Lateral on reference side tube connection 90°	18										x	x	x				(x)	(x)	(x)						x		(x)	(x)		
Lateral opposite reference side grease nipple 67°	20										x	x	x	x	x		(x)	(x)	(x)	(x)	(x)			x		(x)	(x)	(x)		
Lateral opposite reference side grease nipple 0°	22									x	x	x	x	x	x	x	(x)	(x)	(x)	(x)	(x)	(x)	(x)	x	x	x	(x)	(x)	(x)	
Lateral opposite reference side grease nipple 45°	23										x	x	x	x	x		(x)	(x)	(x)	(x)	(x)	(x)			x		(x)	(x)		
Lateral opposite reference side grease nipple 90°	24										x	x	x	x	x		(x)	(x)	(x)	(x)	(x)			x		(x)	(x)	(x)		
Lateral opposite reference side tube connection 0°	27										x	x	x				(x)	(x)	(x)					x	x	x	(x)	(x)	(x)	
Lateral opposite reference side tube connection 90°	28										x	x	x				(x)	(x)	(x)						x		(x)	(x)	(x)	
Front side grease nipple 67° / LU1 on one side	30										x	x	x	x	x		x	x	x	x	x	x	x	x	x	x	x	x	x	
Front side 2 set screws / LU1 on one side	31										x	x	x	x	x	x	x	x	x	x	x	x	x	x	x	x	x	x	x	
Front side grease nipple 0° / LU1 on one side	32										x	x	x	x	x	x	x	x	x	x	x	x	x	x	x	x	x	x	x	
Front side grease nipple 45° / LU1 on one side	33										x	x	x	x	x		x	x	x	x	x	x	x	x	x	x	x	x	x	
Front side grease nipple 90° / LU1 on one side	34										x	x	x	x	x		x	x	x	x	x	x	x	x	x	x	x	x	x	
Front side extension 0° / LU1 on one side	35										x	x	x	x	x		x	x	x	x	x	x	x	x	x	x	x	x	x	
Front side swivel connection / LU1 on one side	36										(x)	(x)	(x)	(x)			(x)	(x)	(x)	(x)										
Front side tube connection 0° / LU1 on one side	37										x	x	x	x			x	x	x	x					x	x	x	x	x	
Front side tube connection 90° / LU1 on one side	38										x	x	x				x	x	x	x					x	x	x	x	x	
Lateral on reference side grease nipple 67° / LU1 on one side	40											x	x	x	x		(x)	(x)	(x)	(x)	(x)				x		(x)	(x)	(x)	
Lateral on reference side grease nipple 0° / LU1 on one side	42										x	x	x	x	x	x	(x)	(x)	(x)	(x)	(x)	(x)	(x)	x	x	x	(x)	(x)	(x)	
Lateral on reference side grease nipple 45° / LU1 on one side	43											x	x	x	x		(x)	(x)	(x)	(x)	(x)				x		(x)	(x)	(x)	
Lateral on reference side grease nipple 90° / LU1 on one side	44											x	x	x	x		(x)	(x)	(x)	(x)	(x)				x		(x)	(x)	(x)	
Lateral on reference side tube connection 0° / LU1 on one side	47										x	x	x				(x)	(x)	(x)						x	x	x	(x)	(x)	(x)
Lateral on reference side tube connection 90° / LU1 on one side	48											x	x	x				(x)	(x)	(x)						x		(x)	(x)	(x)
Lateral opposite reference side grease nipple 67° / LU1 on one side	50											x	x	x	x		(x)	(x)	(x)	(x)	(x)				x		(x)	(x)	(x)	
Lateral opposite reference side grease nipple 0° / LU1 on one side	52										x	x	x	x	x	x	(x)	(x)	(x)	(x)	(x)	(x)	(x)	x	x	x	(x)	(x)	(x)	
Lateral opposite reference side grease nipple 45° / LU1 on one side	53											x	x	x	x		(x)	(x)	(x)	(x)	(x)				x		(x)	(x)	(x)	
Lateral opposite reference side grease nipple 90° / LU1 on one side	54											x	x	x	x		(x)	(x)	(x)	(x)	(x)				x		(x)	(x)	(x)	
Lateral opposite reference side tube connection 0° / LU1 on one side	57										x	x	x				(x)	(x)	(x)						x	x	x	(x)	(x)	(x)
Lateral opposite reference side tube connection 90° / LU1 on one side	58											x	x	x				(x)	(x)	(x)						x		(x)	(x)	(x)

S Standard option
x Option possible
(x) Option conditionally possible (see Chapter 6.6.2)

Lubrication connections (s. Chapter 6.6.2)	Index	Miniature guides										Standard Linear Guides															
		LGM										LGB															
		07B	09B	12B	15B	09W	12W	15W	15B	20B	25B	30B	35B	45B	55B	15F	20F	25F	30F	35F	45F	55F	21W	27W	35W	21T	27T
Front side grease nipple 67° / LU1 on both sides	60								x	x	x	x	x	x			x	x	x	x	x	x	x	x	x	x	x
Front side 2 set screws / LU1 on both sides	61							x	x	x	x	x	x	x	x		x	x	x	x	x	x	x	x	x	x	x
Front side grease nipple 0° / LU1 on both sides	62							x	x	x	x	x	x	x		(x)	x	x	x	x	x	x	x	x	x	x	x
Front side grease nipple 45° / LU1 on both sides	63							x	x	x	x	x	x	x			x	x	x	x	x	x	x	x	x	x	x
Front side grease nipple 90° / LU1 on both sides	64							x	x	x	x	x	x	x			x	x	x	x	x	x	x	x	x	x	x
Front side extension 0° / LU1 on both sides	65							x	x	x	x	x	x	x			x	x	x	x	x	x	x	x	x	x	x
Front side swivel connection / LU1 on both sides	66							(x)	(x)	(x)	(x)					(x)	(x)	(x)									
Front side tube connection 0° / LU1 on both sides	67							x	x	x	x	x			x		x	x	x			x	x	x	x	x	x
Front side tube connection 90° / LU1 on both sides	68							x	x	x	x						x	x	x			x	x	x	x	x	x
Lateral on reference side grease nipple 67° / LU1 on both sides	70								x	x	x	x	x			(x)	(x)	(x)	(x)	(x)			x			(x)	(x)
Lateral on reference side grease nipple 0° / LU1 on both sides	72							x	x	x	x	x	x	x	x	(x)	(x)	(x)	(x)	(x)	(x)	x	x	x	(x)	(x)	(x)
Lateral on reference side grease nipple 45° / LU1 on both sides	73								x	x	x	x	x			(x)	(x)	(x)	(x)	(x)			x			(x)	(x)
Lateral on reference side grease nipple 90° / LU1 on both sides	74								x	x	x	x	x			(x)	(x)	(x)	(x)	(x)			x			(x)	(x)
Lateral on reference side tube connection 0° / LU1 on both sides	77							x		x	x	x			x		(x)	(x)	(x)			x	x	x	(x)	(x)	(x)
Lateral on reference side tube connection 90° / LU1 on both sides	78								x	x	x						(x)	(x)	(x)				x			(x)	(x)
Lateral opposite reference side grease nipple 67° / LU1 on both sides	80								x	x	x	x	x			(x)	(x)	(x)	(x)	(x)			x			(x)	(x)
Lateral opposite reference side grease nipple 0° / LU1 on both sides	82							x	x	x	x	x	x	x	(x)	(x)	(x)	(x)	(x)	(x)	(x)	x	x	x	(x)	(x)	(x)
Lateral opposite reference side grease nipple 45° / LU1 on both sides	83								x	x	x	x	x			(x)	(x)	(x)	(x)	(x)			x			(x)	(x)
Lateral opposite reference side grease nipple 90° / LU1 on both sides	84								x	x	x	x	x			(x)	(x)	(x)	(x)	(x)			x			(x)	(x)
Lateral opposite reference side tube connection 0° / LU1 on both sides	87							x		x	x	x			x		(x)	(x)	(x)			x	x	x	(x)	(x)	(x)
Lateral opposite reference side tube connection 90° / LU1 on both sides	88								x	x	x						(x)	(x)	(x)				x			(x)	(x)
Lubrication connection according customer request	99							x	x	x	x	x	x	x	x	x	x	x	x	x	x	x	x	x	x	x	x

S Standard option
 x Option possible
 (x) Option conditionally possible (see Chapter 6.6.2)

Table 8.2 Index of lubrication greases

Index	Manufacturer	Grease description (see Chapter 4.2.4)
A	NTN	SNR LUB Heavy Duty (standard grease)
B	Klüber	Without grease, only with Contrakor Fluid H1 preservation oil
C	NTN	SNR LUB HIGH SPEED+
D	NTN	SNR LUB HIGH TEMP
E	NTN	SNR LUB FOOD AL
F	Klüber	Microlube GL261
G	Klüber	Klübersynth BEM34-32
H	Klüber	Klübersynth UH1 14-151
N	--	Without any greasing
X		Special grease according to customer specifications

Table 8.3 Index of materials / coatings

Index	Description (see Chapter 7)
0	Standard material
2	Black chrome coating
4	Hard chrome coating
5	DURALLOY® TDC coating

9 Type list

Type	Description	Page
GRN_	Grease nipple	119
HK_A	Manual clamping element for standard guides	107
HK_B	Manual clamping element for wide standard guides	107
HK_M	Manual clamping element for miniature guides	108
KWH_	Active hydraulic clamping elements	116
LA_	Lubrication adapter	124
LBG_-CS	Cover strip	106
LBG_-MT	Mounting tool for cover strip	106
LBG_-SE	Safety element for cover strip	106
LBPS_	Narrow passive pneumatic clamping and braking elements	115
LE_	Extension	120
LG-AC-LUB-KIT-B	Manual grease gun for size 15	125
LGB_	Ball Guides	70 - 89
LGB_-LU1	Lubrication system LU1	117, 118
LGB-AC_-KIT_-	Sealing kits	102
LGB-BEL_	Bellow for ball guides	105, 106
LGB-BEL_-H-MS	Mounting set for bellows	105, 106
LGBC_	Ball carriages with ball chain	70 - 77
LGBCH_B	Ball carriages with ball chain, block type, normal height	74, 75
LGBCH_F	Ball carriages with ball chain, flange type, normal height	70, 71
LGBCS_B	Ball carriages with ball chain, block type, flat version	76, 77
LGBCS_F	Ball carriages with ball chain, flange type, flat version	72, 73
LGBCX_B	Ball carriages with ball chain, block type, medium height	74, 75
LGBR_	Narrow rail for ball guides	98
LGBW_	Wide rail for ball guides	98
LGBX_	Conventional ball carriages	78 - 89
LGBXH_B	Conventional ball carriages, block type, normal height	82, 83
LGBXH_F	Conventional ball carriages, flange type, normal height	78, 79
LGBXH_T	Wide conventional ball carriages, flange type, normal height	86, 87
LGBXH_W	Wide conventional ball carriages, block type, normal height	88, 89
LGBXS_B	Conventional ball carriages, block type, flat version	84, 85
LGBXS_F	Conventional ball carriages, flange type, flat version	80, 81
LGBXX_B	Conventional ball carriages, block type, medium height	82, 83
LG-CAP_	Plastic rail cap	104
LG-CAP_B	Brass rail cap	104
LGM_	Miniature guides	90 - 97
LGMC_	Miniature carriages with ball chain	90 - 93
LGMC_B	Miniature carriages with ball chain, narrow version	90, 91
LGMC_W	Miniature carriages with ball chain, wide version	92, 93
LGMR_	Narrow rail for miniature guides	98
LGMW_	Wide rail for miniature guides	98
LGMX_	Conventional miniature carriages	94 - 97
LGMX_B	Conventional miniature carriages, narrow version	94, 95
LGMX_W	Conventional miniature carriages, wide version	96, 97
LH_	Tube connection	119
LKP_	Compact active pneumatic clamping element	110
LKPS_	Compact passive pneumatic clamping element	112
LS_	Swivel connection	119
LUB GREASE GUN SET	Manual grease gun	125
MBPS_	Passive pneumatic clamping and braking elements	114
MCP_	Active pneumatic clamping element for miniature guides	110, 111
MCPS_	Passive pneumatic clamping element for miniature guides	113
MK_	Active pneumatic clamping element	109
MKS_	Passive pneumatic clamping element	111
MLS	Multi Layer Seal	100, 101
ORL_	O-Ring	124
PHK_	Adapter plate for manual clamping element	107
PKW_	Adapter plate for hydraulic clamping element	116
PLK_	Adapter plate for compact pneumatic clamping element	110, 112, 115
PMB_	Adapter plate for pneumatic clamping and braking element	114
PMK_	Adapter plate for pneumatic clamping element	109, 111
PUB_	Adapter plate for compact pneumatic clamping and braking element	115
SNR-LUBER-CONTROL	Central lubrication system	126
SNR-POLYPUMP	Central lubrication system	126
UBPS_	Compact passive pneumatic clamping and braking elements	115

10 Guide to queries

Company _____
City _____
Contact person _____
Phone _____
Mail _____

Date _____
Offer valid until _____
Address _____
Fax _____

Project description

Once-off requirement Number of items _____ Preferred date _____
 Series requirement Items/year _____ Preferred date for number of items _____ CW

New design Technical upgrade Cost reduction

System description

Number of parallel rails _____
Distance of the (outer) rails: _____ from 4 rails onwards,
distance of the inner rails: _____

Number of carriages: _____
Distance of the (outer) carriages: _____ from 4 carriages: onwards,
distance of the inner carriages: _____

Position of the drive: _____ horizontal (y) [mm] _____ vertical (z) [mm]

Installation position: _____ Longitudinal incline [°] _____ Cross incline [°]

Installation surface: machined _____ unmachined _____

For permanent temperature > 80°C _____ °C

Stroke [mm]: _____

Cycle time [s]: _____

Movement velocity [m/min]: _____ Optional movement time [s]: _____

Acceleration [m/s²]: _____ Acceleration at emergency stop [m/s²] _____

Desired service life time: _____ Cycles or _____ km or _____ hours

Coordinate system

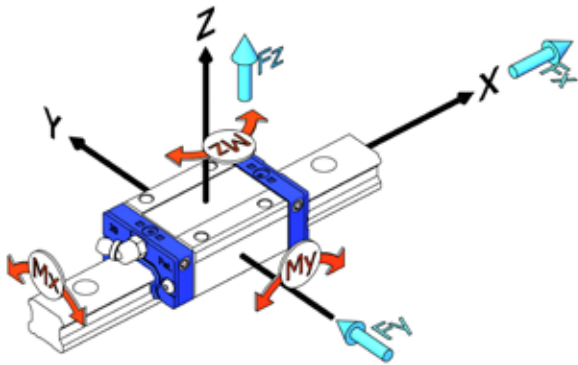

Position of the loads

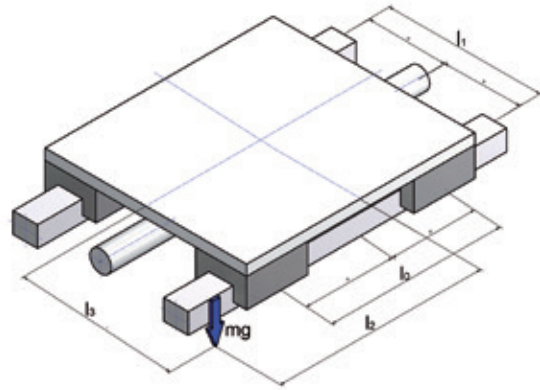

Loads

Load		longitudinal [mm]		horizontal [mm]	vertical [mm]	Travel percentage	Comments
Centre of gravity	[kg]	x_{max}	x_{min}	y	z	[%]	
m1							
m2							
m3							
m4							
m5							
External force		longitudinal [mm]		horizontal [mm]	vertical [mm]	Travel percentage	Comments
Point of action	[N]	x_{max}	x_{min}	y	z	[%]	
Fx		not applicable					
Fy				not applicable			
Fz					not applicable		

Drawing:

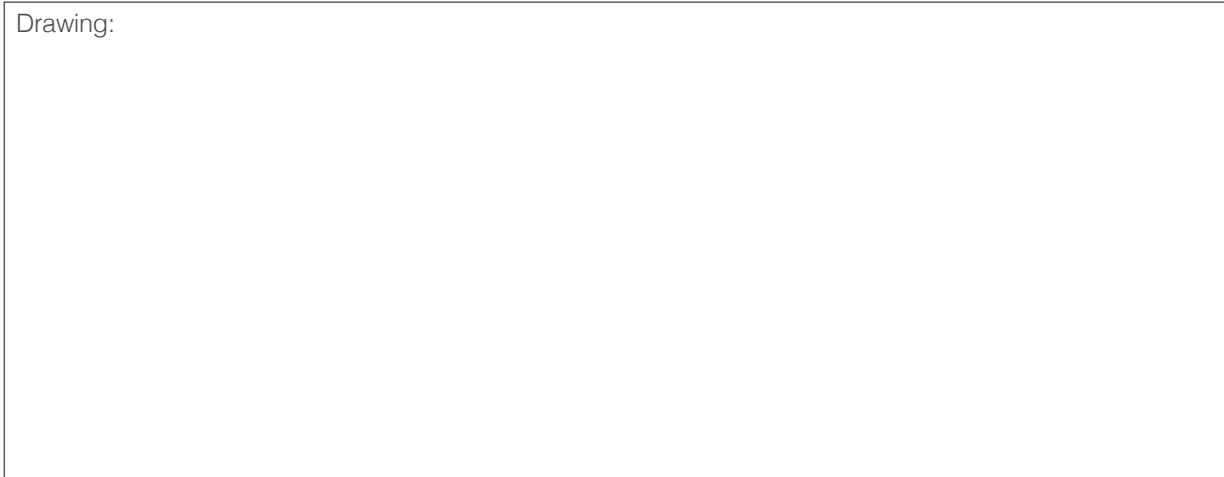

11 Index

A

Accessories 100 - 126
Bellows 105, 106
Clamping- and braking elements 107 - 115
Cover strip 106
Lubrication system LU1 101, 102,
. 117, 118, 121 - 123, 130, 131
Rail caps 104
Sealing Options. 100 - 103
Anti-corrosion oil 60
Arrangement 50, 99
Assembling errors. 9

B

Ball chain 10 - 13
Bellows 105, 106

C

Cage 10, 13, 14
Circular arc groove 8, 43, 68
Clamping and braking elements 107 - 116
Hydraulic clamping elements 116
Manual clamping elements. 107, 108
Pneumatic clamping elements 109 - 113
Pneumatic clamping and braking elements 114, 115
Clean room 62
Coating 127
Black chrome coating 127
Duralloy coating 127
Hard chrome coating. 127
Contact factor 18, 19, 21
Contact surfaces 8, 42, 47
Coordinate system 18
Corrosion protection 127
Cover strip. 106
Mounting tool 106
Safety element 106

D

DB and DF-configuration 9, 42
Differential slip. 8
Dimension G. 99
Driving resistance. 8, 13, 37, 44
Driving force. 45
Dynamic load rating 16

E

End plates 14, 118, 124
Environmental temperature 59
Equivalent load 25, 26
Dynamic equivalent load 25

Equivalence factors 22, 23
Error compensation 42, 68

F

Fastening hole. 104
Fastening screws 48, 53, 58
Fastening torque 58
Food industry 60 - 62
Friction coefficient. 9, 43, 44, 58, 68
Friction force 43, 44

G

Gothic arc groove 8, 43
Grease nipple 63, 118 - 123, 130, 131
Guide to queries. 133, 134

H

Hardness factor 18 - 20
Heat generation 10, 60
Hertz-type compression 16

I

Index for special versions 129
Initial lubrication 64, 66
Installation edge. 47, 48
Installation instructions 52 - 54
Installation position 51, 61
Installation surface 42, 47, 50, 52, 53
Installation tolerance 54 - 57
Height tolerances. 55, 56
Height tolerances in longitudinal direction 57
Parallelism tolerance 54, 55
Intended use 17

J

Joint 49, 99
Jointed rails 49, 99

L

Load factor 19, 21
Load rating 10, 16, 18, 19, 37, 50, 68, 69
Lubricant 10 - 12, 42, 44, 51, 59 - 67, 99, 117, 126
Anti-corrosion oil 52, 60
Low-viscosity grease 59, 61, 62, 64 - 66
Lubrication grease 59 - 64
Lubrication oil. 59 - 64
Properties. 42, 60 - 62
Lubricant volumes. 64, 65
Initial lubrication 60, 64 - 66

Initial operation	64
Re-lubrication.	44, 60, 63 - 67, 118, 124, 125
Re-operation	66
Lubrication	51, 59 - 68, 101, 117 - 126, 130, 131
Influence factors	59, 66
Lubrication film	10, 59
Lubrication intervals	66, 67, 117
Lubrication adapter	124
Lubrication connections	118 - 123, 130, 131
Lubrication depot	11
Lubrication film	10, 59
Lubrication methods	63
Central lubrication system	63, 126
Grease gun	63, 125
Manual grease gun	63, 125
Lubricator LU1	101, 102, 117, 118, 121 - 123, 130, 131
LU1	101, 102, 117, 118, 121 - 123, 130, 131

M

Main and auxiliary guide	47, 49
Main load directions.	18, 39
Maximum acceleration	68, 69
Maximum velocity	68, 69
MLS	100, 101
Multi-Layer-Seal	100, 101
Mounting-Set	105, 106

N

Noise reduction	59, 62
Noise generation	10, 12, 68

O

Osculation.	7, 17, 43
---------------------	-----------

P

Pharmaceutical industry	60 - 62
Pitching	18, 39
Point and area contact	7
Precision classes	40 - 42, 49
Height tolerance	40, 41
Parallelism deviation	40, 41
Width tolerance.	40, 41
Preload	37, 38, 42 - 44
Preload classes	37, 38, 42

R

Raceway	7 - 9, 16, 19, 37, 59, 60, 68, 69, 100, 117, 127
Radial clearance	37, 38
Rail caps.	54
Reference surface.	40, 41, 49, 52, 54, 99, 130, 131

Rigidity	37, 39, 50
Rolling	18, 39
Rolling elements.	6, 8, 10, 16, 18 - 20, 37, 43, 44, 59

S

Safety instructions.	17
Seal	44, 68
Two-lip version	44, 68
Sealing option	100 - 103
Combinations.	101
End seal	100 - 103
Inner seal	100 - 103
Length of the carriage	100 - 103
Metal scraper	100 - 103
MLS.	100 - 103
Sealing kits	100 - 103
Side seal	100 - 103
Sealing resistance.	44
Selection criteria.	15
Service life time	16, 17, 19, 21 - 25, 37, 59, 68
Service life time calculation	19, 21, 25, 37
Spacer ball	13
Special length	99
Standards	16
Standard length	98
Static safety	14
Static load rating.	16
Surface pressure	7, 10
Stick-slip effect	43

T

Temperature factor	18, 19, 21
Tribo-corrosion	62
Torque load	25, 39
Type code	127 - 131
Carriage	128, 129
Linear Guide	128, 129
Linear Guide system	129
Profile rail	128, 129

W

Wear.	8, 10, 12, 14, 22, 59 - 62
---------------	----------------------------

Y

Yawing	18, 39
------------------	--------



NTN

Make the world **NAMERAKA**



DOC_LUG_CAT14_GBB - Code SAP : 707009 - Conception et réalisation : Service publicite NTN Europe © 06/2024 - Photos : © Pedro Studio Photos - Shutterstock

This document is the exclusive property of NTN Europe. Any total or partial reproduction hereof without the prior consent of NTN Europe is strictly prohibited. Legal action may be brought against anyone breaching the terms of this paragraph. NTN Europe shall not be held liable for any errors or omissions that may have crept into this document despite the care taken in drafting it. Due to our policy of continuous research and development, we reserve the right to make changes without notice to all or part of the products and specifications mentioned in this document.
© NTN Europe, international copyright 2024.

NTN Europe - 1 rue des Usines - 74000 Annecy
RCS ANNECY B 325 821 072 - Code APE 2815Z - Code NACE 28.15
www.ntn-europe.com

NTN

SNR

BCA
BEARINGS

BOWER

Brands of
NTN Group