



Brand of NTN Group

LINEAR MOTION: AXE LINEAR AXIS



NTN EUROPE, THE STRENGTH OF A GROUP



Production in Bielefeld

We are one of the largest bearing manufacturers in the world in cooperation with the Japanese company NTN.

SNR, one of NTN Europe's brand, has been established in the linear technology market since 1985 and strives to offer a complete and competitive product range. This position allows us to provide our customers with a high level of added value regarding service, quality and product variety.

Advantages:

- Complete program of linear products
- Production facilities in Europe and Asia
- Optimal support by our technical sales and our application engineers near you – worldwide
- State of the art technology (patented solutions)
- State of the art production methods to ensure highest product quality
- Well organized logistic network to ensure on time delivery
- Finding out the most economical solutions together with our valued customers

Our sales support and applications engineers are always on hand to offer you optimal support.

The consulting and planning service is based on many years of interdisciplinary experience. That means less design effort and costs on the side of the users.

Our sales and applications engineers will gladly help you with their expertise. We are looking forward to your enquiries. Our goal is to achieve joint, constructive solutions.

Product quality, economic efficiency and high user benefits are the basis of a strategic partnership.

NTN and you – our customer.

WE LEAD YOU TOWARDS RELIABILITY AND PERFORMANCE.

SNR Linear Axis of the AXE series are universal modules that accommodate the steadily growing requirements for the automation of installation and manufacturing processes.

They are used in many different applications, such as:

- Packaging and printing machines
- Special and general engineering
- Automotive industry
- Automation and assembly lines
- Wood and paper industry
- Medical engineering
- and much more



The AXE series is designed according to a modular principal and offers; depending on the task various drive systems, a wide range of accessories and combination of options with the shortest possible delivery time.

Advantages:

- Easy product selection and fast configuration
- Standard combination of 2 and 3 Axis systems
- Wide range of accessories for connecting elements, gearboxes, drive adapters and switches
- The Linear Axis can be connected with each other via sliding blocks or special fastening strips
- Multi-axis systems can be equipped with gearboxes, couplings, coupling cones, switches and additionally with energy chains



This technical catalogue provides an overview of our Linear Axis range and forms the basis of our discussions with **you – our customer.**

TABLE OF CONTENTS

1. Technical basics of linear axes	5
1.1 Product features	5
1.2 Drive systems	7
1.3 Guiding system	8
1.4 Selection criteria	9
2. System technology	10
2.1 Definition	10
2.2 Declaration of incorporation for partly completed machinery (Machinery directive 2006/42/EG)	10
2.3 Safety instructions	11
2.4 Intended use	11
2.5 Coordinate system	11
2.6 Static load capacity	12
2.7 Life time	12
2.7.1. Dynamic load capacity/Nominal life time	12
2.7.2. Influence factors	12
2.8 Rigidity	13
2.9 Dynamic operating load	14
2.10 Precision	14
2.11 Gearbox selection	15
2.11.1. Maximum operation speed	15
2.11.2. Maximum acceleration torque	15
2.11.3. Nominal torque on the drive	15
2.12 Drive calculation	16
2.13 Selection of linear axes with toothed belt drive for 90° tilt mounting (wall mounting)	16
3. Mounting and start-up	17
3.1 Transportation and storage	17
3.2 Design of the mounting surfaces/ mounting tolerances	17
3.3 Mounting instruction	19
3.4 Mounting of parallel Linear Axes	20
3.5 Tightening torques	20
3.6 Form-fitted mounting of planetary gearboxes	21
3.7 Force-fitted mounting of couplings	21
3.8 Mounting of planetary gearboxes via coupling and coupling cone	22
3.9 Mounting of the gearbox flange	23
3.10 Drive assembly	24
3.11 Mounting of connecting shafts for parallel linear axes	24

3.12	Mounting of limit switches	25	6.	Accessories	56
3.12.1.	Mounting of limit switches for linear axis AXE_Z (except AXE110Z)	25	6.1.	Fastening and connecting elements	56
3.12.2.	Mounting of inductive proximity switches for groove installation on linear axes AXE60Z, AXE80Z and AXE100Z	26	6.1.1.	Fastening strips	56
3.12.3.	Mounting of limit switches on linear axis AXE110Z and proximity switches for AXE160Z	27	6.1.2.	Sliding blocks	57
3.12.4.	Mounting of limit switches on the drive head of linear axis AXE_A with moved profile	28	6.1.3.	Direct connections	58
3.12.5.	Mounting of limit switches on the profile of linear axis AXE_A with moved drive head Ω	29	6.1.4.	Cross connections	59
3.13	Start-up of Linear Axes	30	6.1.5.	Gantry connections	60
4.	Maintenance and lubrication	31	6.1.6.	A – Standard connections	61
4.1	General information	31	6.1.7.	Angle connections	62
4.2	Lubrication	31	6.2	Drive options	64
4.3	Lubricants	31	6.2.1.	Plug-in shafts	64
4.4	Lubrication methods	32	6.2.2.	Couplings and connecting shafts	65
4.4.1.	Manual grease gun	32	6.2.3.	Planetary gearboxes/Motor adapter	70
4.4.2.	Automatic electro-mechanical lubricator DRIVE BOOSTER	32	6.2.3.1	Form-fitted mounting of the planetary gearboxes	72
4.5	Lubrication points	33	6.2.3.2	Force-fitted mounting of planetary gearboxes via coupling and coupling cone	73
4.6	Amounts of lubricant	33	6.3	Limit switches	75
4.7	Lubrication intervals	34	6.3.1.	Limit switch versions	75
4.8	Cover strip replacement	35	6.3.2.	Cable guiding	76
4.8.1.	Cover strip replacement for the linear axes AXE110 and AXE160	35	6.3.3.	Mounting versions	76
4.9	Wear parts sets	35	6.3.4.	Technical data	80
5.	SNR linear axes AXE	36	6.3.5.	Possible switch combinations	81
5.1	General view	36	6.4	Energy chains	82
5.1.1.	Series	36	6.5	Groove inserts	82
5.1.2.	Main parameters	37	6.6	Lubrication connections	83
5.2	AXE Efficiency line axes with toothed belt drive	38	7.	Multi Axis Systems	84
5.2.1.	Structure	38	7.1	Standard Axis System	84
5.2.2.	Dimension/Technical data	39	7.1.1.	Standard Axis System A	85
5.2.3.	Maximum static load capacity	49	7.1.2.	Standard Axis System B	86
5.2.4.	Dynamic load capacity	49	7.2	Dynamic load capacity of Standard Axis Systems	87
5.3	AXE Efficiency Line axes with toothed belt/Ω - drive	50	7.3	Limit switch combinations for Standard Axis Systems	88
5.3.1.	Structure	50	8.	Type code	88
5.3.2.	Dimensions/Technical data	51	9.	Type list / ID Number list	89
5.3.3.	Maximum static load capacity	55	10.	Fits	96
5.3.4.	Dynamic load capacity	55	11.	Guide to queries	98
			12.	Index	99



1. Technical basics of linear axes

1.1 Product features

SNR has developed a completely new series (Figure 1.1) of standard axes with the AXE linear axes.



Figure 1.1 SNR linear axis AXE

The main features of this series are:

- Short delivery time
- Cost-optimized design
- Single axis and axis systems including accessories configurable online
- Light and high rigid aluminum profiles as base
- Maximum protection of the guiding systems placed inside the profile against pollution and damages
- Unchanged high quality level
- Optimum ease of maintenance and service
- Individual axis configurations through a wide range of available fastening elements and accessories for the flexible design of single and multi-axis systems
- Fast assembly

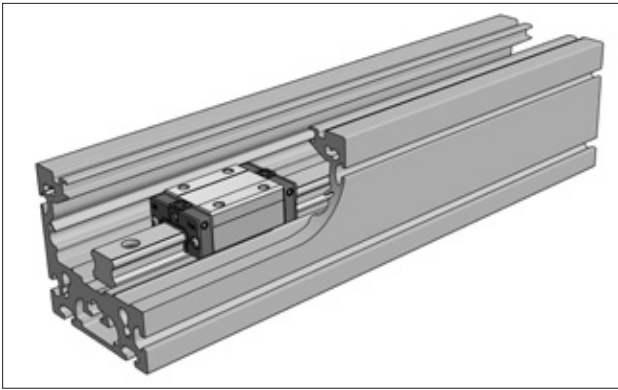

Figure 1.2 Profile with screwed linear guide

The base profile assumes the guiding rails of the linear guides. The linear guides are screwed to the profile (Figure 1.2). The base profile is of anodized aluminum, which largely determines the stiffness of a linear axis.

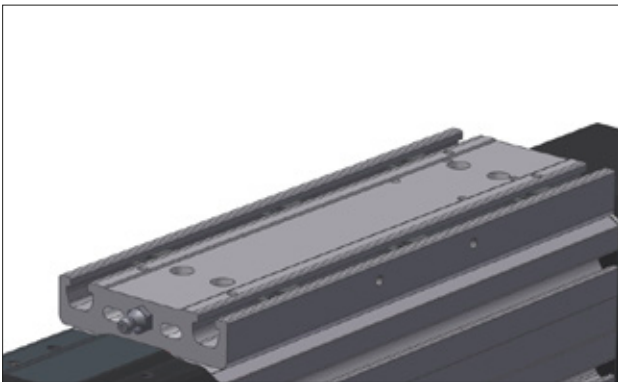

Figure 1.3 Slider unit with profile grooves

The slider unit is a complex assembly group usually consisting of an aluminum profile or aluminum components. The carriages of the guiding system are mounted on the slider unit. The slider unit also compounds the drive elements with the guiding elements of a linear axis. On its upper side the slider unit is provided with profile grooves (Figure 1.3) to secure the customer's extensions.

The slider units are equipped with easily accessible service points for the lubrication of the guiding system (Figure 1.4 up to 1.6).

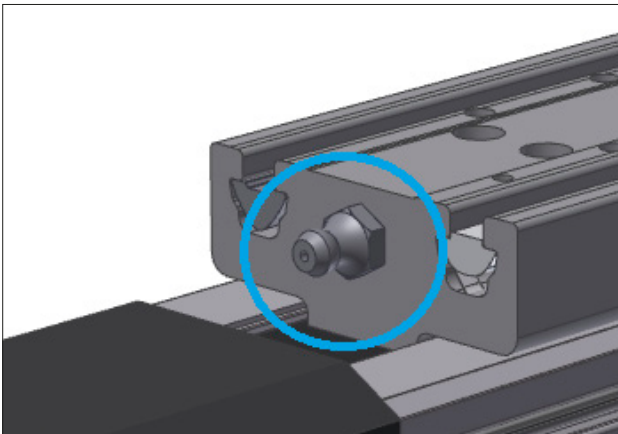

Figure 1.4 Slider unit with one service point on the front side

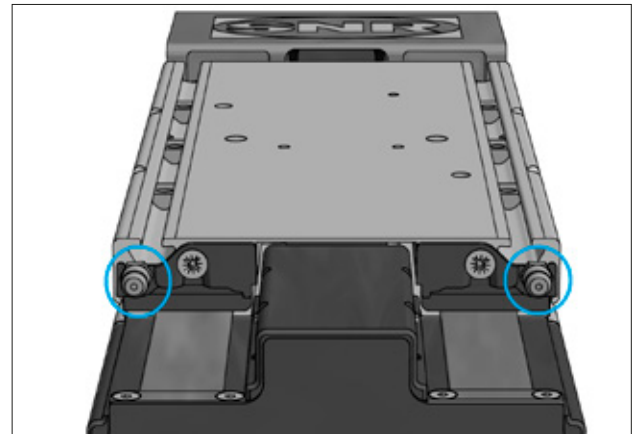

Figure 1.5 Slider unit with two service points on the front side

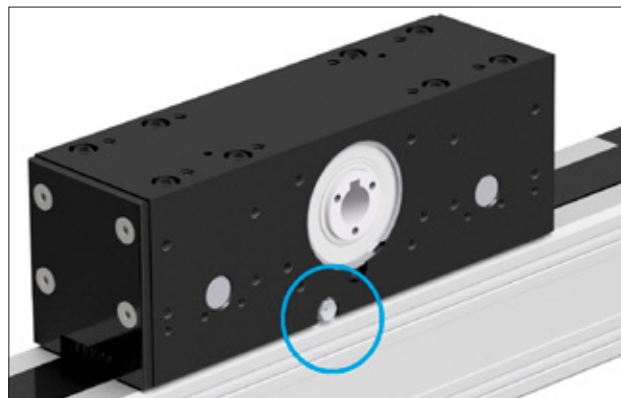

Figure 1.6 Drive head with lateral service points

1.2 Drive systems

The SNR AXE linear axes series are equipped with toothed belt drive, which makes them suitable for fast handling and positioning applications.

All linear axes are equipped with AT or STD toothed belt drives. These are extruded polyurethane belts with integrated steel cords. The AT toothed belt drives are of zero-gap shape. Using black toothed belts prevents discoloration of the toothed belts under UV - radiation.

These toothed belts have the following features:

- Low wear
- Maintenance free
- High tensile strength and low elongation
- High precision – pitch error $\pm 0,2$ mm/m
- UV – resistant
- Temperature range from -25°C to $+75^{\circ}\text{C}$
- Low noise level

The special design of the toothed belt clamping via tooth segments (Figure 1.7) allows unweakened belt clamping.

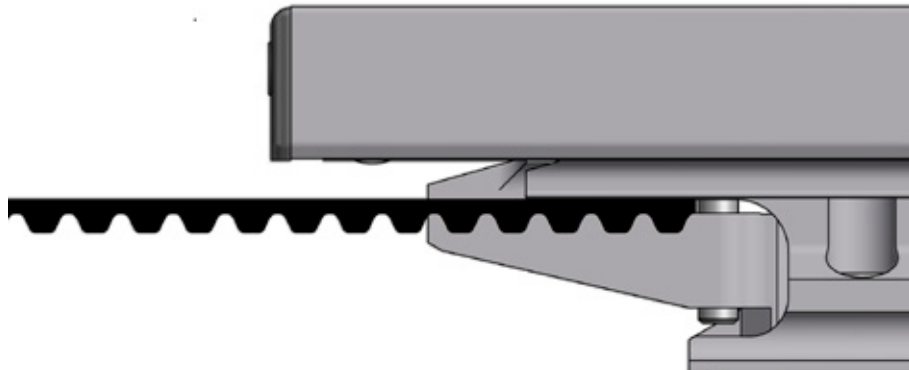

Figure 1.7 Toothed belt clamping

Adjusting the toothed belt tension for SNR linear axes by a radially moveable deflecting pulley (Figure 1.8).

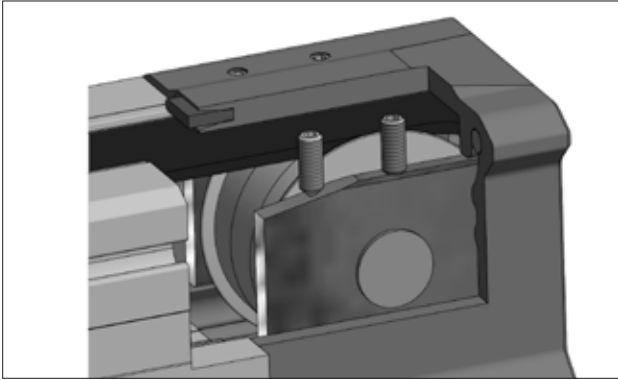

Figure 1.8 Toothed belt tension

Setting the correct toothed belt tension with the SNR measuring device, which is equipped with a force sensor to adjust the exact toothed belt tension (Figure 1.9).



Figure 1.9 Measuring device for the toothed belt tension

As a result, there will be no risk of overloading the toothed belt or pulley bearing due to excessive toothed belt tension. Furthermore, centered alignment will ensure optimum driving characteristics and low wear.

Advantages:

- Highly dynamic
- Great lengths possible
- Cost efficient
- Maintenance free drive element

1.3 Guiding system

The SNR linear axes AXE series are equipped with linear guides and ball chain technology (Figure 1.10). By arranging raceways at a 45° angle, the SNR linear guides can be used universally having equal load ratings in all main load directions. One of the special features of SNR linear guides with ball chains are their integrated lubricant reservoirs. Using these linear guides has the following advantages:

- High load ratings
- High service life time
- Long-term maintenance free
- Low heat generation
- High tolerance and error compensation capacity by DF – configuration of the raceways
- Low noise level
- High running smoothness
- High velocity up to 5 m/s
- High acceleration up to 50 m/s²

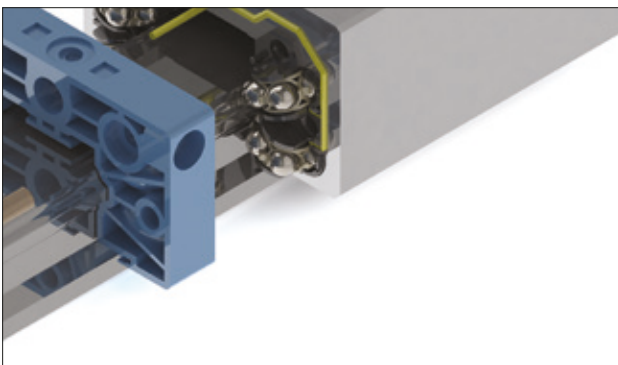
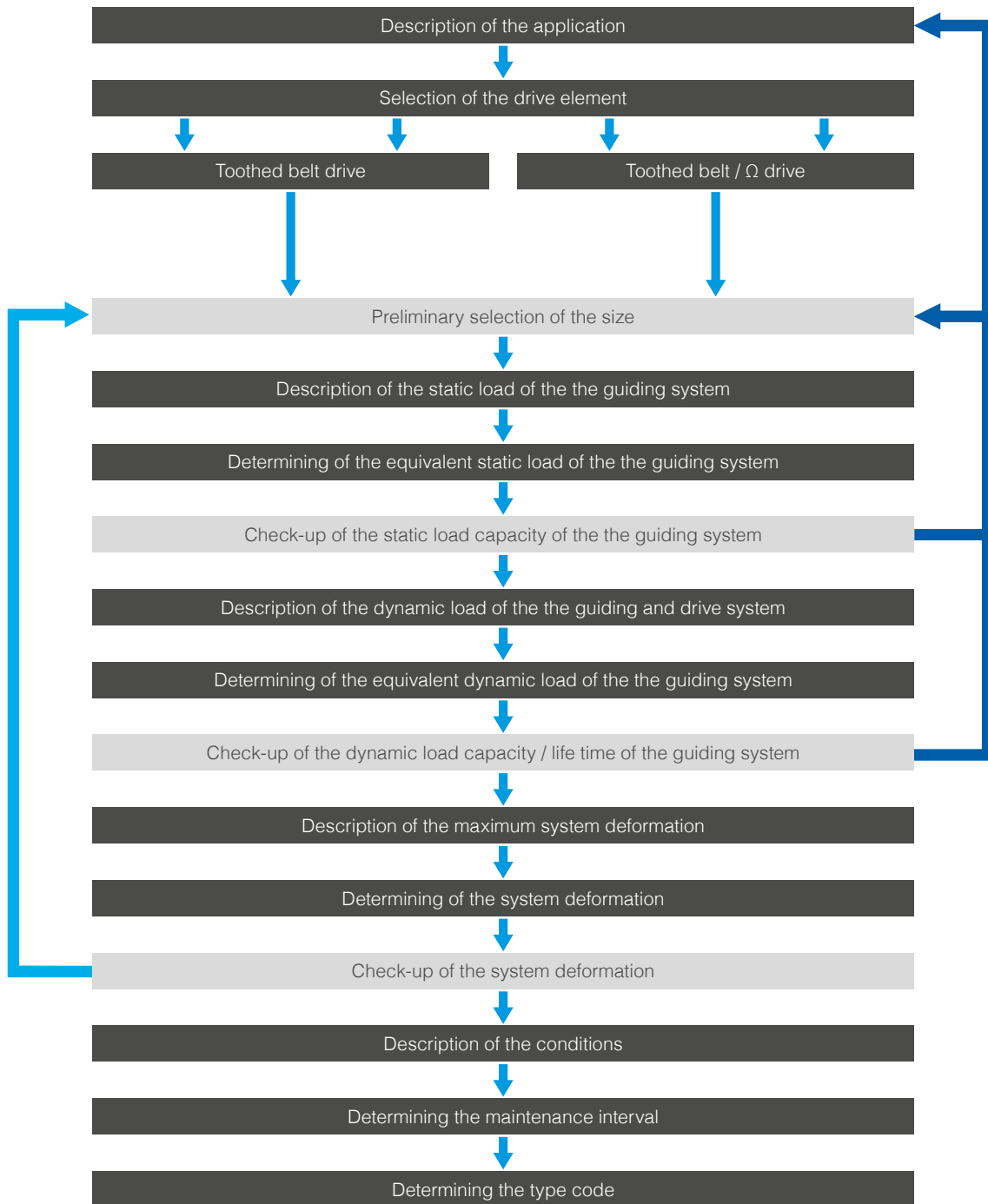

Figure 1.10 SNR – Linear guides with ball chain



1.4 Selection criteria



2. System technology

2.1 Definition

Linear axes are pre-finished units with a combination of precise guiding and driving elements. Thereby linear axes and their variations are cost efficient and extremely compact components for machines and systems, which can be mounted and put into operation within the shortest time.

Criteria for the selection of linear axes could be as follows:

POSITIONING REPEATABILITY	When positioning repeatability, an arbitrary point is approached several times in one direction from the same starting point and the deviation to the target value is measured. The process is repeated for different points. $\pm 50\%$ of the difference between maximum and minimum deviation is given as positioning repeatability.
POSITION ACCURACY	When measuring the positioning accuracy several points are approached in one direction and the difference between the target travel distance and the actually travelled distance is measured. The position accuracy is the absolute maximum difference.
RUNNING PARALLELISM	The dial gauge is centrally mounted on the carriage and moved over the complete stroke. The running parallelism is the maximum difference between the measured values.

For the selection of SNR linear axes our sales and application engineers with years of experience will also be glad to assist you.

2.2 Declaration of incorporation for partly completed machinery (Machinery directive 2006/42/EG)

The manufacturer **SNR Wälzlager GmbH, Friedrich-Hagemann-Straße 66, D-33719 Bielefeld, Germany** as the manufacturer of the partly completed machinery from the series "Linear axis AXE" hereby declares:

- The following essential health and safety requirements in accordance to Annex I of the machinery directive 2006/42/EG are applied and adhered to:
 - General principles:**
 - 1.1. General remarks
 - 1.2. Protection against mechanical hazards
 - 1.3. Risks due to other hazard
 - 1.4. Maintenance
 - 1.5. Information
- The relevant technical documentation has been established in accordance with part B of Annex VII.
- In case of any reasoned request from the national authorities, we will transmit the relevant technical documentation in accordance with part B of Annex VII.
- The afore mentioned relevant technical documentation can be obtained from :
QC Department, SNR Wälzlager GmbH, Friedrich-Hagemann-Straße 66, D-33719 Bielefeld, Germany.
- The conformity is in accordance with the EN ISO 12100: 2010
«Safety of machinery - General principles for design - Risk assessment and risk reduction».
- Start-up of the partly completed is forbidden until the linear axis or the linear axis system - whatever applies -, into which this is to be incorporated, has been declared to be in conformity with the provisions of the machinery directive 2006/42/EG.



i.V. Ulrich Gimpel (Industry Engineering Division Head)
SNR Wälzlager GmbH - Friedrich-Hagemann-Straße 66 D-33719 Bielefeld, Germany
Bielefeld, December 2019

2.3 Safety instructions



The device is built according to current state-of-the-art technology and applicable regulations. The device complies with the EU machinery directive, harmonized standards, European standards or the applicable national standards. This must be confirmed by a manufacturer's declaration.

Relevant accident prevention regulations, generally accepted safety-related rules, EU guidelines, other applicable standards and country-specific regulations are also applicable.

Since linear units can be used in a wide range of applications, the ultimate responsibility and liability for appropriate use lies with the end user.

This device is posing unavoidable residual risks for personal injury and material damage. For this reason, every individual working on this device associated with the transport, assembly, operating, maintenance and repair of the device, must receive instructions and understand potential hazards. All information on mounting, start-up, maintenance and lubrication must be understood and observed.

2.4 Intended use

SNR linear axes are basically designated for linear movement as during positioning, synchronization, transport, palletizing, loading, unloading, clamping, tightening, testing, measuring, handling and manipulating components or tools. Type-specific load data from the relevant catalog documentation and/or SNR supplementary technical calculations must be observed.

Furthermore, an operating temperature between -10°C and $+80^{\circ}\text{C}$ must be adhered to.

2.5 Coordinate system

The linear axis can be stressed by forces or torques. The coordinate system (Figure 2.1) shows the forces acting in the main load directions, the torques as well as the six degrees of freedom.

Forces in the main load directions:

F_x Movement force (X direction)

F_y Tangential load (Y direction)

F_z Radial load (Z direction)

Moments:

M_x Torque in roll direction (rotation around the X axis)

M_y Torque in pitch direction (rotation around the Y axis)

M_z Torque in yaw direction (rotation around the Z axis)

In addition, operating equipment poses a risk of injury due to rotating or otherwise moving components. Due to moving carriages, the operational linear axis particularly poses an increased crushing hazard, especially in connection with end position dampers and limit switches. The user must make these residual risks known by signs or written codes of conduct. Alternatively, the user can eliminate or exclude these residual risks to the greatest extent possible by employing appropriate constructive measures.

The noise level may increase at high speeds, special applications and the accumulation of more noise sources. The user must take the appropriate protective measures.

The linear axis start-up is prohibited until it can be established that the machine or system in which it is mounted conforms to EU machinery directives, harmonized standards, European standards or applicable national standards.

Alternative or excessive use is considered improper use.

The manufacturer assumes no liability for resulting damages.

The user bears sole responsibility for all risks.

The linear axis may only be operated and serviced by individuals familiar with the axis and who have been advised about the dangers.

In special applications (such as food industry, clean room etc.), special precautions must be taken by the user which deviate from the standard version.

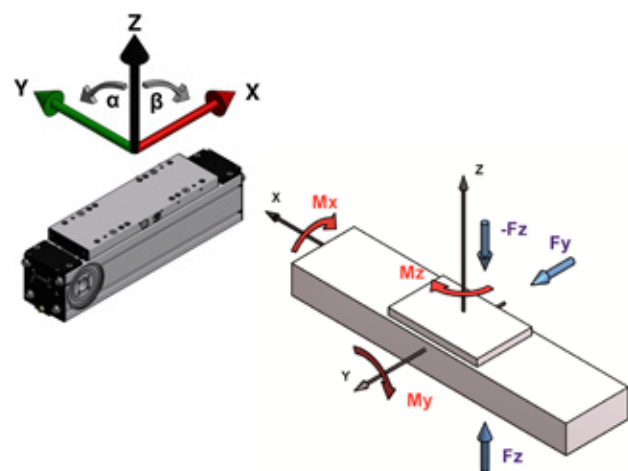

Figure 2.1 Coordinate system

2.6 Static load capacity

The values of the static load capacity given in the data tables of the linear axis represent the maximum applicable load. The loads (radial and tangential) and moments can act simultaneously from different directions on the linear axis (Figure 2.2).

In this case, a maximum equivalent load consisting of radial, tangential and other loads, is used for verification. For this, the position must be located within the movement cycle in which the interaction of all loads has the maximum value. For complex loads, we recommend to contact our application engineers. A minimum safety factor for static load capacity is not given here.

The static load capacity must not be confused with the static load rating which is specified in the calculation of linear guides. The static load capacity of a linear axis results from the maximum load capacity of all related components in their interaction and is lower than the static load rating of the guiding system.

No additional inspection of the guiding system's safety is required.

If a linear axis is subjected in static alternating loads use, the values of the dynamic load capacity shall be recognized as the maximum values in this case.

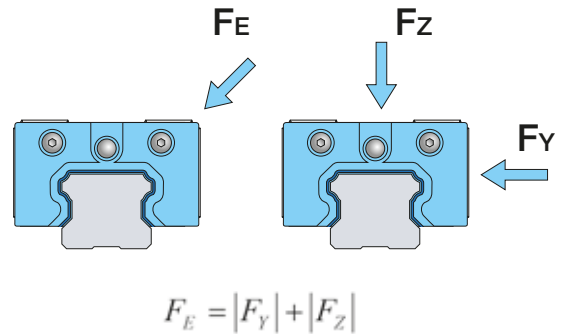

Figure 2.2 Equivalent load

2.7 Life time

2.7.1. Dynamic load capacity / Nominal life time

The catalog data for the dynamic load capacity of the linear axis AXE are based on the nominal life time of 50 000 km. The change of the nominal life time depending on the load is shown in Figure 2.3.

If the loads are below the described limits, no further investigation is necessary.

When calculating the nominal life time of the linear axis, the calculation basis for linear guides described in the relevant catalog must be applied.

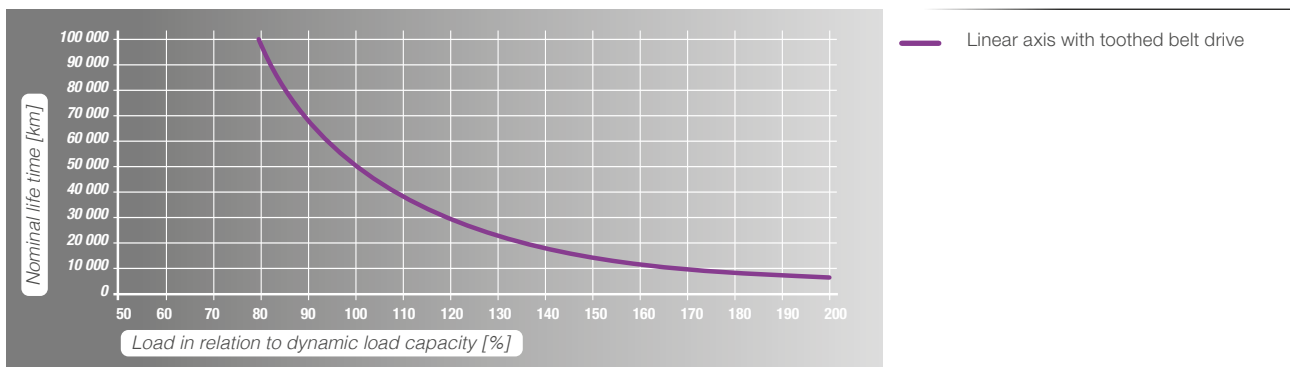

Figure 2.3 Nominal life time

For higher dynamic loads, please contact our application engineers or use our calculation service for complex loads.

2.7.2. Influence factors

For calculating the nominal life time, the real acting loads are often very difficult to be determined exactly. Linear axes are generally exposed to oscillations or vibrations caused by process or driving forces. They must be dimensioned such that the load peaks of shocks do not exceed the maximum permissible loads. This applies to the dynamic as well as the static operational state of the system.

2.8 Rigidity

The rigidity of a linear axis is specified by the correlation between the external load and the resultant elastic deformation in the load direction. The rigidity is a key parameter for the selection of the linear axis, since the rigidity values are changing depending on the type and version of the SNR linear axis.

Basically, the rigidity of the linear axis is determined by the rigidity of the aluminum profile.

The total deformation of a system also depends on the following external factors:

- Type of loads (point loads, line loads or moment loads)
- Type of fixation of the linear axis
- Length of the linear axis
- Distance of the fastening points

Some examples of calculating the bending of the linear axis are specified in Table 2.1

Table 2.1 Bending of linear axis

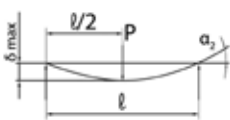
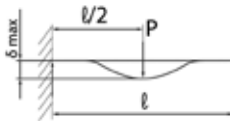
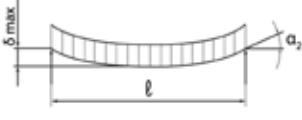
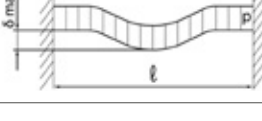
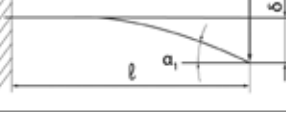
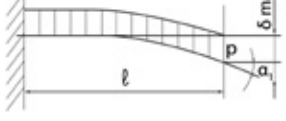
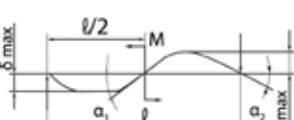
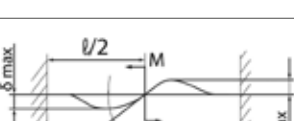
Kind of bearing	Specification	Bending	Bending
Support - Support		$\delta_{\max} = \frac{Pl^3}{48EI}$	$\alpha_1 = 0$ $\tan \alpha_2 = \frac{Pl^2}{16EI}$
Fixed - Fixed		$\delta_{\max} = \frac{Pl^3}{192EI}$	$\alpha_1 = 0$ $\alpha_2 = 0$
Support - Support		$\delta_{\max} = \frac{5pl^4}{384EI}$	$\tan \alpha_2 = \frac{pl^3}{24EI}$
Fixed - Fixed		$\delta_{\max} = \frac{pl^4}{384EI}$	$\alpha_2 = 0$
Fixed - Free		$\delta_{\max} = \frac{Pl^3}{3EI}$	$\tan \alpha_1 = \frac{Pl^2}{2EI}$ $\alpha_2 = 0$
Fixed - Free		$\delta_{\max} = \frac{pl^4}{8EI}$	$\tan \alpha_1 = \frac{pl^3}{6EI}$ $\alpha_2 = 0$
Support - Support		$\delta_{\max} = \frac{\sqrt{3}Ml^2}{216EI}$	$\tan \alpha_1 = \frac{Ml}{12EI}$ $\tan \alpha_2 = \frac{Ml}{24EI}$
Fixed - Fixed		$\delta_{\max} = \frac{Ml^2}{216EI}$	$\tan \alpha_1 = \frac{Ml}{16EI}$ $\tan \alpha_2 = 0$

2.9 Dynamic operating load

The existing dynamic operating load must be determined and compared with the permissible dynamic operation load for linear axes with toothed belt drive.

The dynamic operating load is calculated by the formula [2.2].

$$F_{z\text{dyn}} = \frac{T_0 * 2\pi}{P} + m * a + m * g * \sin \alpha$$
 [2.2]

$F_{z\text{dyn}}$	Existing dynamic operating load [N]
T_0	Idling speed torque [Nm]
P	Feed constant [m]
m	Moved mass [kg]
a	Acceleration [ms^{-2}]
g	Gravity constant [9.81 ms^{-2}]
α	Assembling position [°]

$$F_{z\text{dyn}0} \geq F_{z\text{dyn}}$$
 [2.3]

$F_{z\text{dyn}0}$	Permissible dynamic operation [N]
$F_{z\text{dyn}}$	Existing dynamic operation [N]

2.10 Precision

The running parallelism of linear axes is mainly determined by the tolerances of the aluminum profiles used. The profiles used by us meet or exceed the requirements of EN12020-2 for precision profiles.

The most common requirement in applications of linear axes is the repeatability. These values are specified in the data tables for all SNR linear axes.

For further information, please contact our application engineers.

2.11 Gearbox selection

When selecting the gearbox for a linear axis the following aspects must be considered:

- Maximum operating speed
- Maximum acceleration torque
- Nominal torque at the output drive

These parameters are manufacturer information taking into account the mechanical and thermal limits of the gearbox which must not be exceeded.

2.11.1. Maximum operation speed

$$n = \frac{v * 60}{P}$$

[2.4]

n Actual operation speed [min⁻¹]
v Velocity [ms⁻¹]
P Feed constant [m]

$$n_{max} \geq n$$

[2.5]

n_{max} Maximum permissible operation speed [min⁻¹]
n Actual operation speed [min⁻¹]

2.11.2. Maximum acceleration torque

$$T_{max} = T_0 + \frac{m * a * P}{2\pi} + \frac{m * g * \sin \alpha * P}{2\pi}$$

[2.6]

T_{max} Actual operation speed [Nm]
T₀ Idling speed torque [Nm]
P Feed constant [m]
m Moved mass [kg]
a Acceleration [ms⁻²]
g Gravity constant [9.81 ms⁻²]
α Assembling position [°]

$$T_{amax} \geq T_{max}$$

[2.7]

T_{amax} Maximum permissible acceleration torque [Nm]
T_{max} Actual acceleration torque [Nm]

2.11.3. Nominal torque on the drive

$$T = T_0 + \frac{m * g * \sin \alpha * P}{2\pi}$$

[2.8]

T Actual torque on the drive [Nm]
T₀ Idling speed torque [Nm]
P Feed constant [m]
m Moved mass [kg]
g Gravity constant [9.81 ms⁻²]
α Assembling position [°]

$$T_a \geq T$$

[2.9]

T_a Permissible nominal torque on the drive [Nm]
T Actual torque on the drive [Nm]

2.12 Drive calculation

Calculations of drives may be established by the respective drive manufacturer only.

The reason for this is that we do not have all the calculation tools and basic data required for these drives.

2.13 Selection of linear axes with toothed belt drive for 90° tilt mounting (wall mounting)

For linear axes with a toothed belt drive in a 90° tilted arrangement (wall mounting), during operation the toothed belt can be displaced downwards by the gravity force to the flanged pulley. We therefore recommend not to exceed the stroke limit lengths specified in Table 2.2.

Table 2.2 Stroke limit length for Linear Axis with toothed belt drive for wall mounting

Type	Stroke limit length [mm]
AXE60Z	2 000
AXE80Z	2 500
AXE100Z	3 000
AXE110Z	2 000
AXE160Z	2 500

During operation, the centered run of the toothed belt must be controlled together with the maintenance of the linear axis specified in Chapter 4.7.

3. Mounting and start-up

3.1 Transportation and storage

SNR linear axes are high-precision components. Heavy shocks may damage the mechanics of the linear axes and affect their functioning. To avoid damage during transportation and storage, the following points must be observed:

- Protection against strong vibrations or shocks, aggressive substances, moisture and contamination.
- Sufficiently large packaging and protection to secure against slipping during transportation.
- Linear axis may have higher weights and sharp edges. Transportation must be carried out only by qualified staff with appropriate protective equipment (safety shoes, gloves, ...).
- Linear axes and packages with linear axes may have greater lengths. To prevent excessive bending during transportation, the linear axes and their packaging must be supported at least at two points, for lengths over more than 3 m at three points.

3.2 Design of the mounting surfaces / mounting tolerances

Any deviation of the fatness, straightness and parallelism of Linear Axes or mounted axis systems will lead to tensions causing additional loads on the guiding elements and reducing the life time. **In general, the higher the load and kilometrage, the higher the requirements for the mounting and alignment of the linear axis or the axis system.**

For proper functioning of single axes or axis systems their longitudinal straightness must be ensured by aligning the individual axes as specified in Table 3.1:

Table 3.1 Straightness tolerance for the mounting of Linear Axis

Size	Straightness tolerance after mounting / m [mm]
all	0.5

For linear axes the permissible tolerance in the fatness (twisting) and the bending in the longitudinal direction is also dependent on the torsional rigidity of the Y - axis or the cross traverse. The resulting moment loads (M_y) must not exceed the catalog values (minus load torque). It must be noted that simultaneous variations in straightness (Table 3.1), fatness, bending and parallelism (tolerance e_0 and e_1 , Table 3.2) will result in increasing loads on the guiding system and must be taken into account pro rata.

Additional requirements for the quality of the mounting surfaces must be considered when the tables of parallel installed linear axes are rigidly connected. For a parallel installation, mainly the linear axes of the AXE60, AXE80 and AXE100 are suitable.

If parallel installation of linear axes from other sizes is required, please contact our application engineers to assist you in the selection process.

The mounting surfaces of the linear axes as well as those for the cross traverse should be machined in the assembly area in a single setup or be adjustable. For the straightness of the mounting surfaces transversal to the moving direction the base tolerance e_0 and the parallelism tolerance e_1 of the linear axes from Table 3.2 (Figure 3.1) should be achieved.

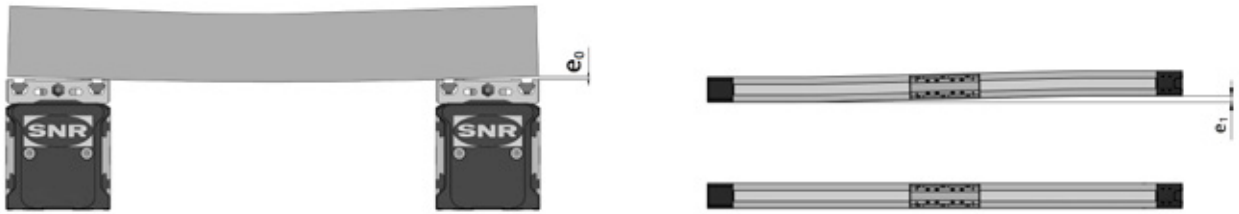

Figure 3.1 Tolerances of parallel linear axis

Table 3.2 Mounting tolerances of parallel linear axis

Type	Base tolerance e_0 for traverses [mm]	Base tolerance e_0 for Standard Axis Systems ¹ [mm]	Parallelism tolerance e_1 [mm]
AXE60	0.010	0.300	0.018
AXE80	0.010	0.300	0.020
AXE100	0.020		0.022

¹ see Chapter 7

If machining of the mounting surfaces according to the above-mentioned requirements is not intended or this value is exceeded by the deflection of the cross traverse, the parallelism must be checked and corrections be made if necessary.

The diagram in Figure 3.2 shows the relationship between mounting tolerances and possible dynamic load capacities.

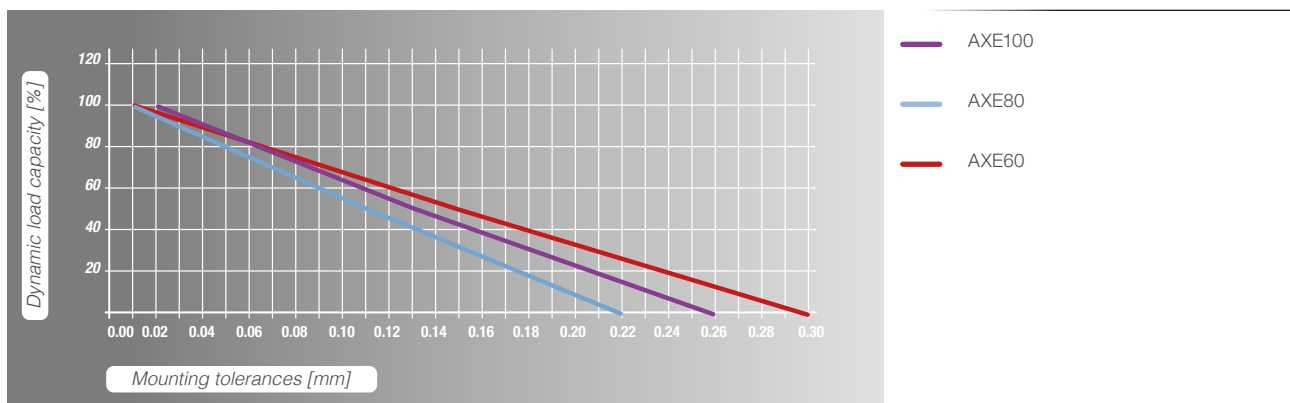

Figure 3.2 Dynamic load capacity of Linear Axis related to the mounting tolerances

3.3 Mounting instruction

When mounting the linear axis (incomplete machine) the conditions listed below must be fulfilled to enable assembly with other parts to form a complete machine and without affecting the health and safety of the staff.



Caution!

The motor housing may reach high temperatures during operation.

The linear axis must be installed such that the structure-borne noise transmission is minimized. Other machine parts should be designed so that they do not lie in the resonance range of the linear axis.

SNR linear axis of the AXE series can be fastened by sliding blocks or fastening strips to plane surfaces or other linear axes from the AXE range. The number of mounting points must be matched to the application.

The fastening strips are laterally hooked into the linear axis profile and, thanks to its special design, they are easy to assemble by screwing from above (Figure 3.3).

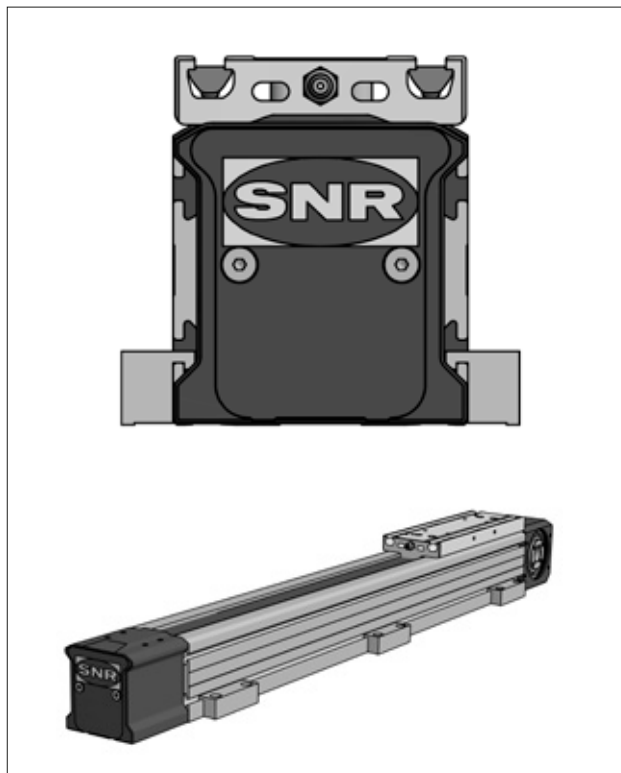

Figure 3.3 Fastening strips AXE

Optionally, linear axes can also be mounted on swivel-sliding blocks, which may be freely positioned along the entire profile length (Figure 3.4).

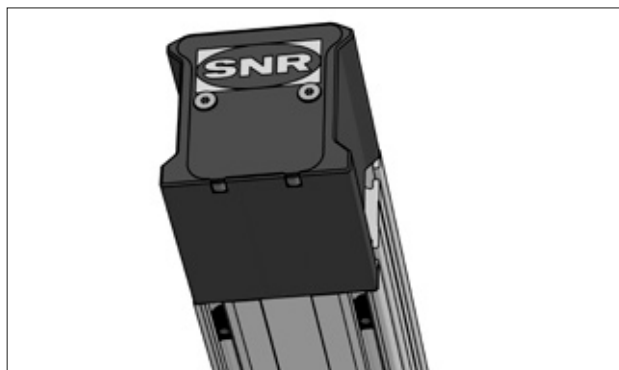

Figure 3.4 Sliding blocks AXE

As a rule, the number of mounting points must be matched to the application in all types of fastening. By punctual support of the linear axis, the resulting bending does neither impair the functioning nor the required accuracy.

3.4 Mounting of parallel Linear Axes

We generally recommend the alignment of parallel linear axes with an assembled crossbar. This is the only safe method to reduce tensioning and thus interferences with the life time to a minimum. The mounting must be carried out according to the following steps:

1. Align the first linear axis (drive axis) straight and assemble completely.
2. Align the second linear axis parallel and the ends in line.
Tighten only slightly for inspection as described in point 6.
3. Move the tables in one end position.
4. Place the traverse (or crossbar).
5. If a relevant deflection is to be expected, apply the load or simulate.
6. Check the base tolerance e_0 (Chapter 3.2) with the feeler gauge.
If necessary, insert foil sheets or correct the angular position of the linear axis.
7. Align and fix traverse (or crossbar)
8. Loosen the mounting screws of the parallel linear axis to allow slight displacements.
9. Move the table to the respective mounting position and tighten screws. Start with the end positions.
10. Finally, loosen all connections to the tables again and retighten.

3.5 Tightening torques

For all assemblies described below, the tightening torques of the screws are summarized in Table 3.3 and 3.4.

Table 3.3 Tightening torque of the couplings

Type	Tightening torque		
	Clamping hub coupling [Nm]	Gearbox [Nm]	Gearbox flange [Nm]
AXE40A	1.34	2.06	0.98
AXE60A AXE60Z	10.00	6.86	4.41
AXE80Z	10.00	6.86	4.41
AXE100Z	25.00	33.3	14.70
AXE110Z	10.00	6.86	4.41
AXE160Z	10.00	6.86	4.41

Table 3.4 Tightening torques for drive assembly

Type	Shaft diameter [mm]	Clamping screw	
		Wrench size [Nm]	Tightening torque [Nm]
AXE40A	all	3	2.0
AXE60A AXE60Z	≤ 14	3	4.5
	19	4	9.5
AXE80Z	all	4	9.5
AXE100Z	all	5	16.5
AXE110Z	≤ 14	3	4.5
	19	4	9.5
AXE160Z	all	4	9.5

3.6 Form-fitted mounting of planetary gearboxes

The form-fitted mounting of planetary gearboxes on linear axis with toothed belt drive must proceed according to the following steps (Figure 3.5). The tightening torques from Table 3.3, Chapter 3.5 must be considered.

1. Place the adapter flange **2** on the planetary gearbox **1** and tighten fastening screws **3**. If this is not smoothly possible, pull the gearbox shaft into the hollow shaft with a screw and washer.
2. Insert the gearbox shaft with the feather key into the hollow shaft **6** of the linear axis. If this is not smoothly possible, pull the gearbox shaft into the hollow shaft with a threaded rod and washer. Place the washer **5** (if present) onto the adapter flange and fasten to the drive head using the screws **4**.

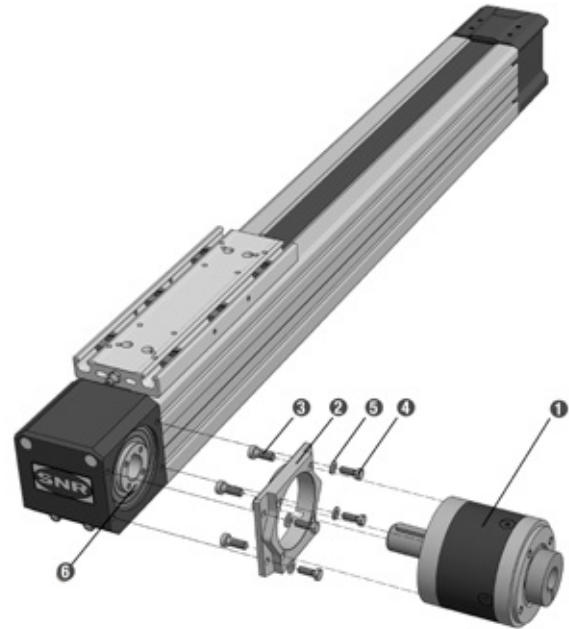

Figure 3.5 Form-fitted mounting of planetary gearboxes on linear axis with toothed belt drive

3.7 Force-fitted mounting of couplings

The force-fitted mounting of couplings on linear axes with toothed belt drive must be performed according to the following steps (Figure 3.6). The tightening torques from Table 3.3, Chapter 3.5 must be considered.

1. Insert the coupling hub **1** with feather key **2** into the hollow shaft of the linear axis.
2. Screw the coupling hub onto the hollow shaft using the fastening screws **3**.
3. Insert elastomeric gear rim **4**.

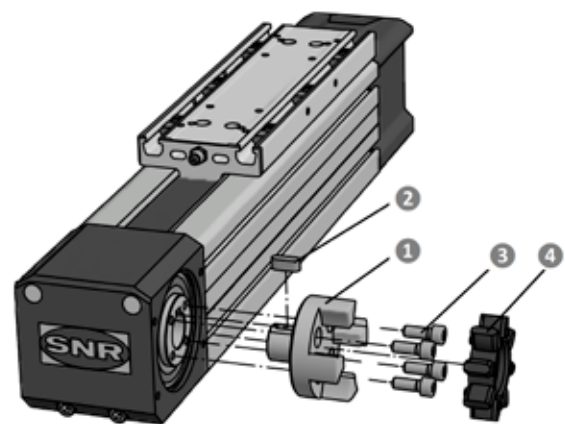

Figure 3.6 Force-fitted mounting of couplings on Linear Axis with toothed belt drive

3.8 Mounting of planetary gearboxes via coupling and coupling cone

The mounting of planetary gearboxes via coupling and coupling cone on linear axes with toothed belt drive must be performed according to the following steps (Figure 3.7). The tightening torques from Table 3.3, Chapter 3.5 must be considered.

1. Insert the gearbox shaft **2** into the coupling hub **1** and tighten the coupling hubs with the tensioning screw **3**.
2. Place the planetary gearbox **1** on the coupling cone **4** and screw together with the fastening screws **5**.
3. Insert this assembly into the coupling half with elastomer gear rim screwed to the drive head **6**, and tighten them with the screws **7**. Consider the dimensions LK and L2 (Figure 3.8) from Table 6.20, Chapter 6.2.3.2.

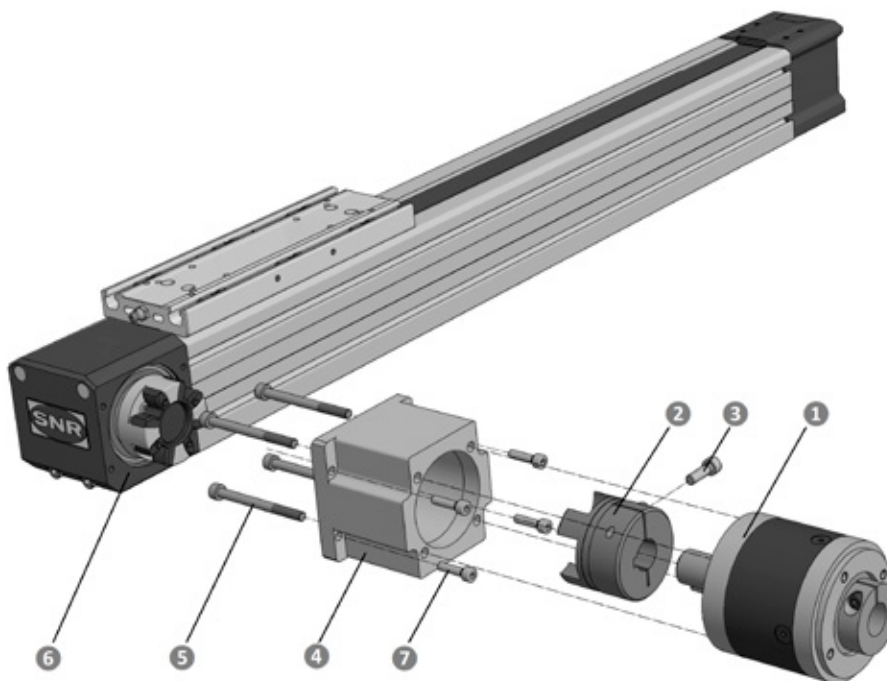

Figure 3.7 Mounting of planetary gearboxes via coupling and coupling cone

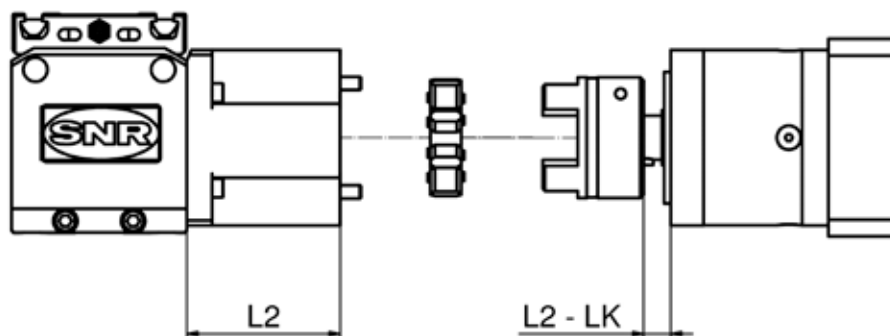

Figure 3.8 Mounting dimension

3.9 Mounting of the gearbox flange

For the different dimension of the motor flanges, different gearbox flanges are available for the planetary gearboxes. The mounting of the gearbox flanges must be performed according to the following steps (Figure 3.9), irrespective of whether the gearbox is connected to the linear axis in a form-fitted manner or mounted via coupling and coupling cone. The tightening torques from Table 3.3, Chapter 3.5 must be taken into account.

1. Place the gearbox flange **2** on the planetary gearbox **1**.
2. Attach the gearbox flange by using the fastening screws **3**.

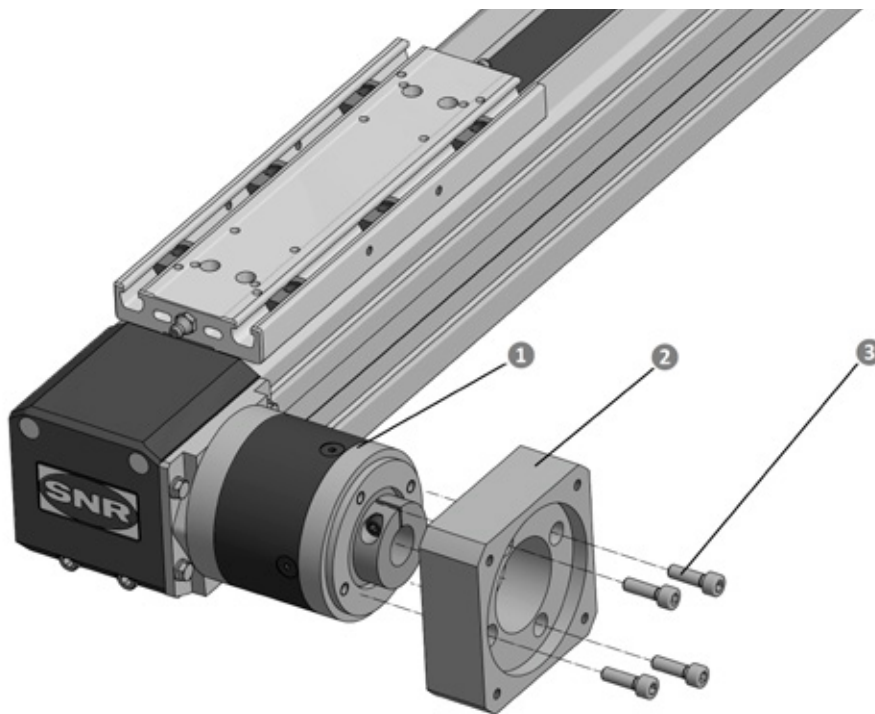

Figure 3.9 Mounting of the gearbox flange

3.10 Drive assembly

The assembling of drives on linear axes with toothed belt drive and planetary gearbox must be performed according to the following steps (Figure 3.10). The tightening torques from Table 3.4, Chapter 3.5 must be considered.

1. Place the linear axis **1** laterally so that the mounting flange **2** of the drive upwards.
2. Degrease the drive shaft, bore of the hollow shaft and bolt spacer.
3. Move the slider **3** until the clamping screw becomes visible in the access hole **4**.
4. If a bolt spacer is needed for the motor shaft diameter, this must be inserted into the gearbox bore. Make sure that the slot of the bolt spacer is offset by 90° to the clamping screw.
5. Insert drive **5**.
6. Insert and tighten the fastening screws **6**.
7. Tighten the clamping screw with the required tightening torque.
8. Close the access hole in the mounting flange of the drive **2** with the supplied plug.

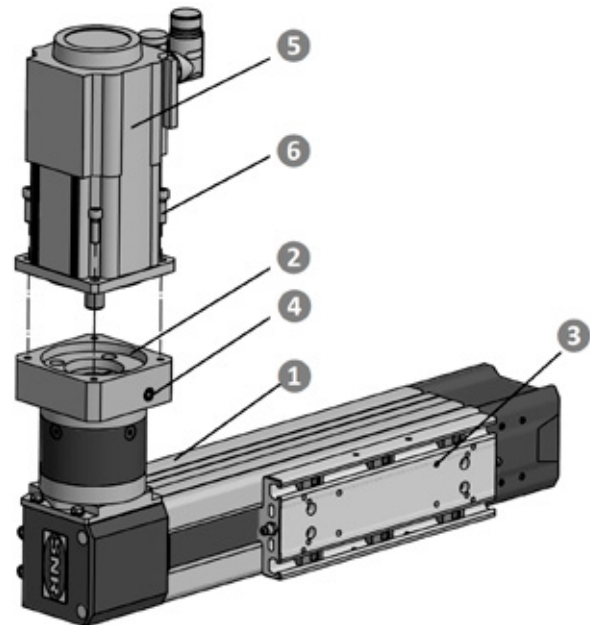

Figure 3.10 Drive assembly on linear axis with planetary gearbox

3.11 Mounting of connecting shafts for parallel linear axes

The mounting of connecting shafts for parallel linear axes with toothed belt drive must be performed according to the following steps (Figure 3.11). The tightening torques from Table 3.3, Chapter 3.5 must be considered.

1. Mounting of the linear axes as specified in Chapter 3.2 and 3.4.
2. Mount the coupling hubs **1** as described in Chapter 3.7.
3. For parallel linear axes with connecting shaft, couplings with half-shell clamping hubs **2/5** are used.
4. Move the slider units **4** from both linear axis into one end position.
5. Insert one half of each half-shell clamping hubs **2** into the elastomer gear rims.
6. Position the connecting shaft **3**, insert the second half of the half-shell clamping hubs **5** and screw tight. The half-shell couplings allow subsequent mounting and dismounting of the connecting shaft without dismounting the linear axes.

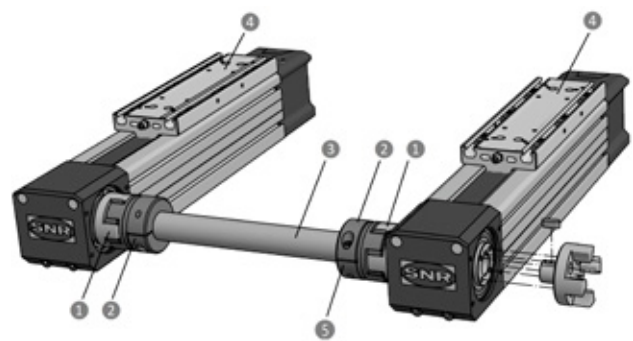

Figure 3.11 Mounting of parallel linear axis with connecting shaft

3.12 Mounting of limit switches

Depending on the version, linear axes of the AXE series can be equipped with mechanical limit switches or inductive proximity switches.

The respective limit switches and the actuating element (Chapter 6.3.5) are provided with the specified ID number as a complete mounting kit including all screws and fastening elements.

In the following chapters, the mounting of the limit switches for the various drive variants is described.

3.12.1. Mounting of limit switches for linear axis AXE_Z (except AXE110Z)

For the mounting of the limit switches and actuating elements the following steps must be taken into account according to Figure 3.12. The table **1** and the profile **2** of the linear axis are designed symmetrically to allow mounting on both sides.

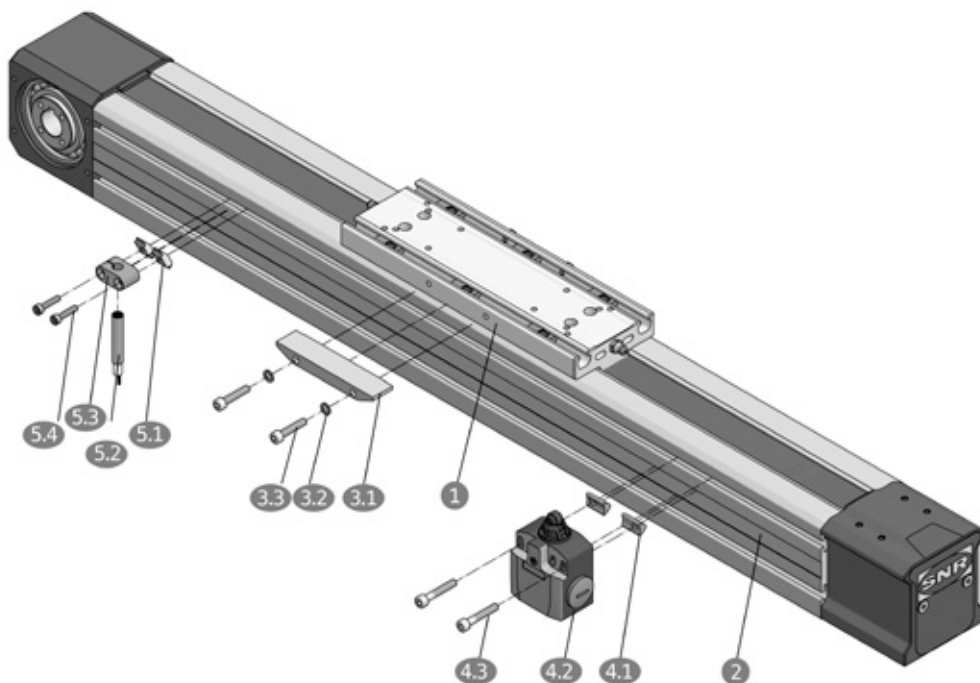

Figure 3.12 Mounting of limit switches for linear axis AXE_Z

Actuating element

Place the washers **3.2** on the screws **3.3** and screw the actuating element **3.1** of the limit switches to the table **1**. It is important to ensure that the bevels of the actuating element are facing down.

Mechanical limit switches

Swing the sliding blocks **4.1** into the upper lateral groove of the profile **2**. Move the limit switches **4.2** with the sliding blocks and the screws **4.3** to the desired switching position and fasten tight.

Inductive proximity switches (except for AXE160Z)

Fasten the bracket of the limit switch **5.3** with the screws **5.4** slightly to the sliding blocks **5.1**. Insert the sliding blocks **5.1** into the upper lateral groove of the profile **2** and tighten the screws **5.4** until the sliding blocks **5.1** turn into the groove. Insert the inductive proximity switch **5.2** from below into the bracket from below **5.3** and adjust it to a maximum distance of 1.2 mm from the actuating element **3.3** and tighten the screws **5.4**.

The inductive proximity switches of the linear axis AXE160Z are mounted on the profile top.

The mounting is the same as for the linear axis AX110Z specified in Chapter 3.12.3.

3.12.2. Mounting of inductive proximity switches for groove installation on linear axes AXE60Z, AXE80Z and AXE100Z

As an alternative to the limit switches described in Chapter 3.12.1, the linear axes AXE60, AXE80 and AXE100 may also be equipped with inductive proximity switches for groove installation. The mounting of the limit switches and the actuating element must be carried out in the following steps according to Figure 3.13. For this switch version, table ① and the profile ② of the linear axis are also symmetrically designed, to allow mounting on both sides is possible.

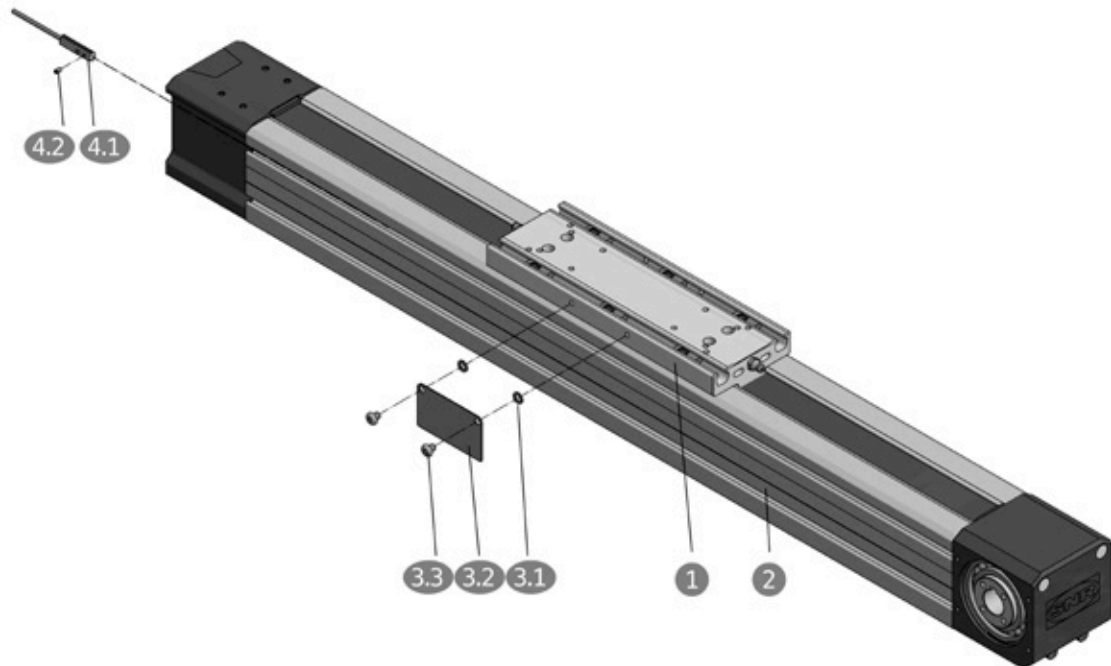

Figure 3.13 Mounting of inductive proximity switches for groove installation

Actuating element

Insert the screws ③.3 through the holes of the actuating element ③.2, place the washers ③.1 on the screws and screw the unit to the lateral threaded holes of the table ①.

Inductive proximity switches for groove installation

Insert or swing in the limit switches ④.1 from the deflection side into the upper groove of the profile ②.

After positioning, screw the limit switches tight with the set screws ④.2. It must be ensured that the cable guiding of the limit switch on the drive side takes place as described

in Chapter 6.3.2. An adjustment of the switching distance is not necessary. For AXE80 and 100, the groove should be closed by a groove insert for safe cable routing. The groove insert is not part of the switch set and must be ordered separately (ID number 101841, chapter 6.5).

3.12.3. Mounting of limit switches on linear axis AXE110Z and proximity switches for AXE160Z

For the mounting of the limit switches and actuating elements the following steps must be performed according to Figure 3.14. The table **1**, the drive head **2.2** and the deflection head **2.3** of the linear axis are designed symmetrically for mounting on both sides.

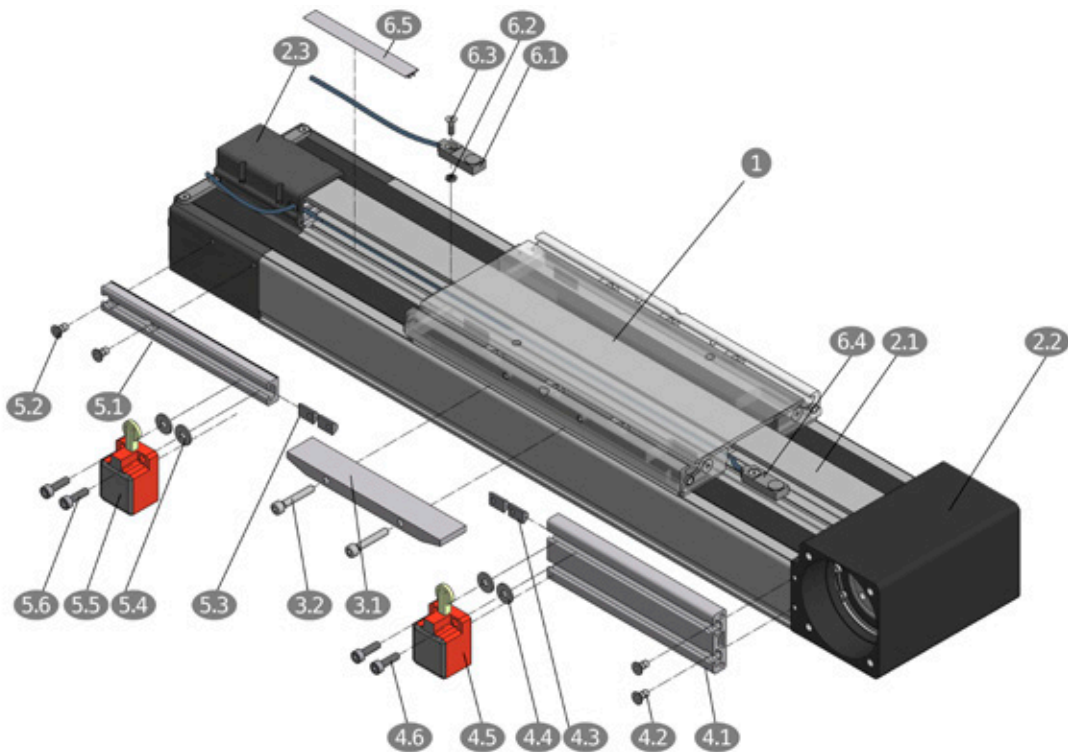

Figure 3.14 Mounting of limit switches on linear axis AXE110Z

Actuating element

Insert the screws **3.2** through the holes of the actuating element **3.1** and screw the unit to the lateral threaded holes of the table **1**.

Mechanical limit switches on the drive head

Fix the profile segment **4.1** to the drive head **2.2** with screws **4.2**. Insert the sliding blocks (Form E) **4.3** into the upper groove of profile segment **4.1**. Insert the screws **4.6** through the holes of the limit switch **4.5**, place the washers **4.4** and screw the unit with the sliding blocks **4.3**.

Mechanical limit switches on the deflection head

Fix the profile segment **5.1** to deflection head **2.3** with screws **5.2**. Insert the sliding blocks (Form E) **5.3** into the groove of the profile segment **5.1**. Insert the screws **5.6** through the holes of the limit switch **5.5**, place the washers **5.4** and screw the unit to the sliding blocks **5.3**.

Inductive proximity switches

Insert the hexagon nuts **6.2** through the recess on the deflection side into the upper groove of the profile **2.1** and position them. Pass the cable of the drive-side

switch **6.4** under the table **1**. Fix the proximity switches **6.1** and **6.4** tighten with the screws **6.3**. It must be ensured that the cable guiding is carried out as shown in figure 3.15. An adjustment of the switching distance is not necessary. The upper profile groove should be closed by a groove insert **6.5**. The groove insert (ID number 173218, Chapter 6.5) is not part of the limit switch set and must be ordered separately.

Cable guiding

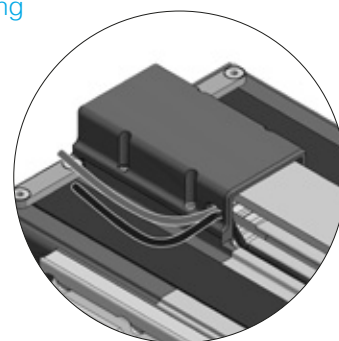

Figure 3.15 Cable guiding for inductive proximity switches AXE110Z

3.12.4. Mounting of limit switches on the drive head of linear axis AXE_A with moved profile

When mounting the limit switches and actuating elements the following steps must be performed according to Figure 3.16. The drive head **1** and the profile **2** of the linear axis are arranged symmetrically to allow mounting on both sides.

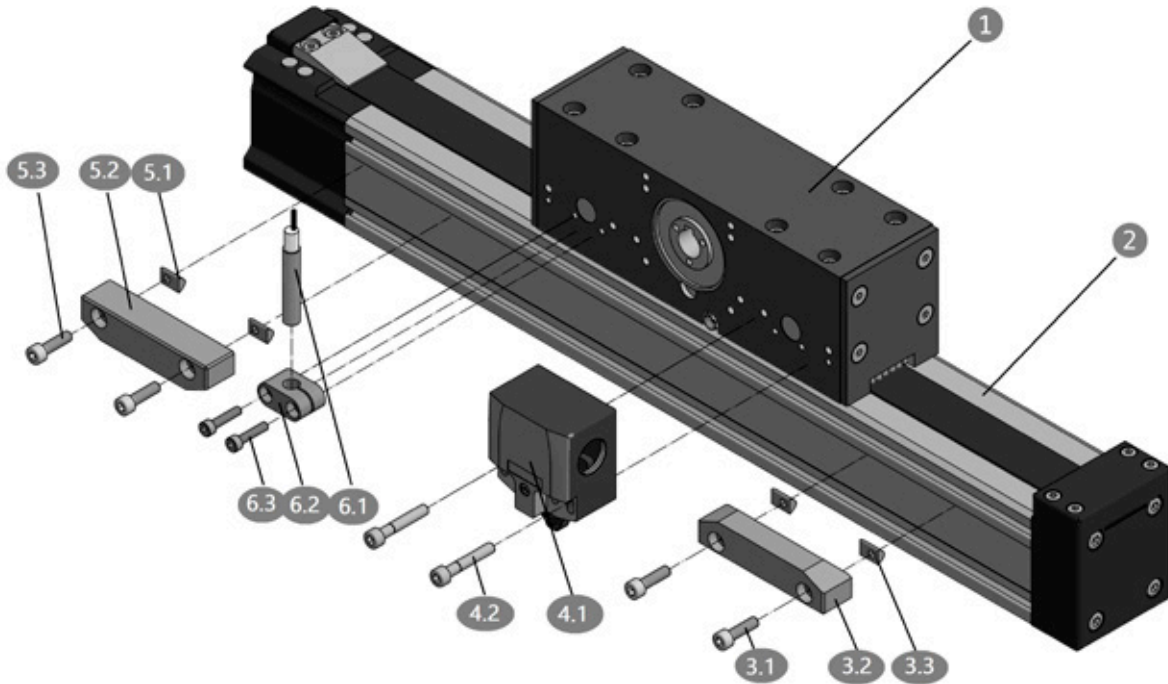

Figure 3.16 Mounting of limit switches on the drive head of linear axis AXE_A with moved profile

Actuating element for mechanical limit switches

Insert the sliding blocks **3.3** into the upper groove of the profile **2**. Insert the screws **3.1** through the holes of the actuating element **3.2** and tighten it to the sliding blocks **3.3**. Ensure that the bevels of the actuating element are facing up.

Mechanical limit switches

Insert the screws **4.2** through the mounting holes of the limit switches **4.1** and screw them to the drive head **1**.

Actuating element for inductive proximity switches

Insert the sliding blocks **5.1** into the upper groove of the profile **2**. Insert the screws **5.3** through the holes of the actuating element **5.2** and screw tight to the sliding blocks **5.1**. Ensure that the bevels of the actuating element are facing down.

Inductive proximity switches

Attach the bracket of the limit switch **6.2** slightly with the screws **6.3** to the drive head **1**. Insert the inductive proximity switch **6.1** from above into the bracket **6.2** and adjust it to a maximum distance of 1.2 mm from the actuating element **5.2** and tighten the screws **6.3**.

3.12.5. Mounting of limit switches on the profile of linear axis AXE_A with moved drive head Ω

For the mounting of the limit switches and actuating elements the following steps must be performed according to Figure 3.17. The drive head **1** and the profile **2** of the linear axis are designed symmetrically so that mounting on both sides is possible.

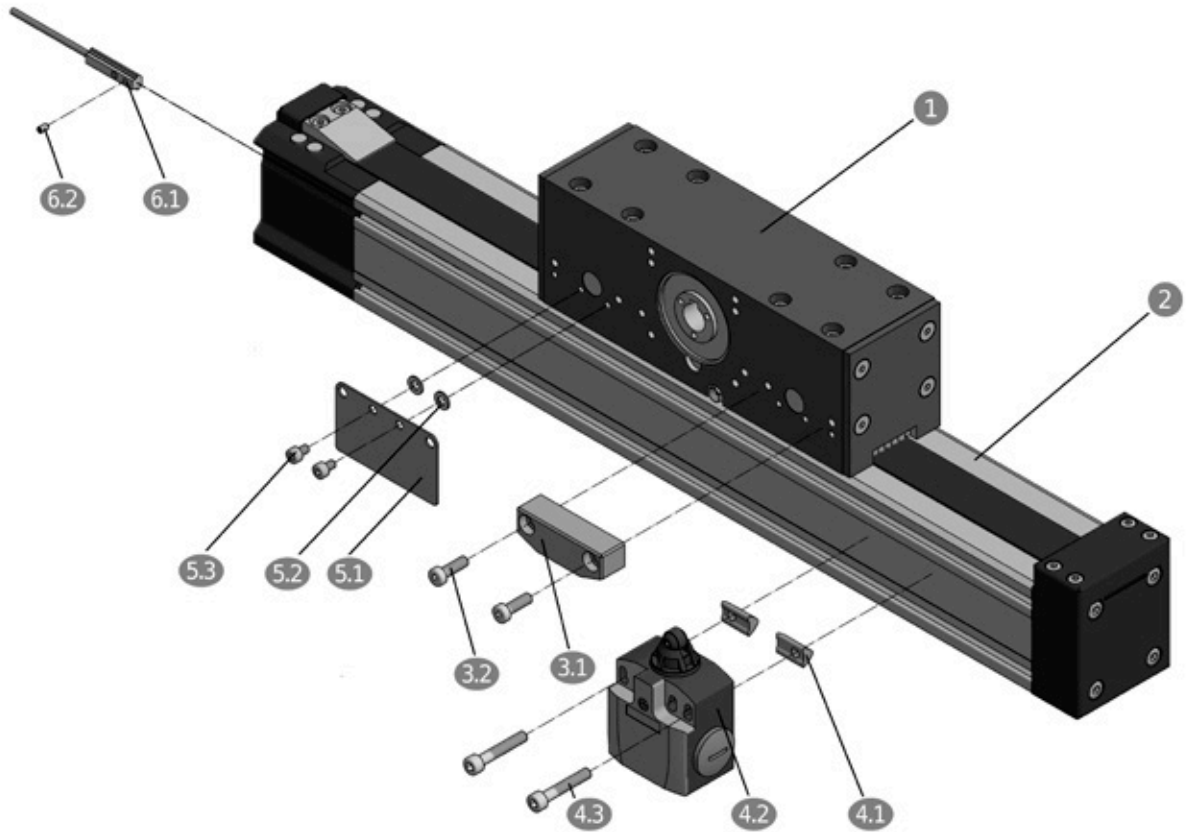

Figure 3.17 Mounting of limit switches on the profile of Linear Axis AXE_A with moved drive head

Actuating element for mechanical limit switches

Insert the screws **3.2** through the holes of the actuating element **3.1** and screw it to the drive head **1**. It is important to ensure that the bevels of the actuating element are facing down.

Mechanical limit switches

Insert the sliding blocks **4.1** into the upper groove of the profile **2**. Insert the screws **4.3** through the mounting holes of the limit switches **4.2** and screw them to the sliding blocks **4.1**.

Actuating element for inductive proximity switches

Insert the screws **5.3** through the holes of the actuating element **5.1**, place the washers **5.2** and screw the unit with the drive head **1**.

Inductive proximity switches for groove installation

Insert the limit switch **6.1** from the deflection side into the upper groove of the profile **2**. Tighten the switches after positioning with the set screws **6.2**. It is important to ensure that the cable guiding as shown in Chapter 6.3.2, is carried out. An adjustment of the switching distance is not necessary.

3.13 Start-up of Linear Axes

Linear axes may travel at high velocities with a large degree of force. Slider fittings may cause bodily injuries or material damage upon collision. Start-up should thus be performed with the utmost caution.

Furthermore, it should be ensured upon start-up that the permissible loads are not exceeded and the slider fittings are securely mounted. It should also be ensured that the maximum possible travel distance is not exceeded. If the travel distance is limited by limit switches, these should be previously tested in terms of performance and correct positioning.

Hazards may arise through unintentional descending of vertical linear axes. The end user must take the necessary precautions according to EN ISO 13849-1.



The manufacturer is not liable for damages resulting from non-observance of these start-up instructions.
The user bears sole responsibility for all risks.

4. Maintenance and lubrication

4.1 General information



Caution!

All maintenance and service works on the linear axis may only be carried out in switched-off and secured state. The motor housing may reach high temperatures during operation.

4.2 Lubrication

For reliable operation of the linear axes, sufficient lubrication is essential.

The lubrication must form a lubricant film (oil film) between the rolling elements and raceways of the guiding and drive elements to avoid wear and premature fatigue of the components.

In addition, the metallic surfaces are protected against corrosion. The lubricant film also enhances smooth sliding

of the seals on the surfaces and minimizes their wear.

Insufficient lubrication not only increases the wear but also significantly reduces the life time.

Optimal selection of the lubricant influences the functioning and life time of the linear axes significantly. In order not to impair but to maintain the functioning of the system over a long period regular maintenance according to ambient conditions and specific requirements should be defined.

Examples for potential ambient conditions and influencing factors:

- Condensation and splash water effects
- High vibration stress
- High acceleration and velocity
- Continuous short stroke movements (< Table length)
- Dirt and dust

4.3 Lubricants

When lubricating the guide system of the linear axis, the lubricant has the following functional tasks:

- Reduction of friction
- Reduction of starting torque
- Protection against premature wear
- Corrosion protection
- Noise reduction

Linear Guides

Lithium soap greases with the marking KP2-K according to DIN 51825 and NLGI class 2 according to DIN 51818 with EP additives are to be used under normal conditions. SNR LUB HEAVY DUTY is used as standard grease in the linear axes of the AXE series.

Table 4.1 provides the data for the lubricant SNR LUB HEAVY DUTY used for our linear guides. The use of greases containing solid additives (for example, graphite or MoS₂) is not permissible.

Table 4.1 SNR LUB HEAVY DUTY

Description	Base oil / Type of soap	NLGI class DIN51818	Worked penetration DIN ISO 2137 at 25°C [0,1mm]	Basic oil viscosity DIN 51562 at 40°C [mm ² /s]	Density [mg/cm ³]	Propertie	Application area
SNR LUB HEAVY DUTY	- Mineral oil - Lithium with EP additives	2	295	ca. 115	890	Very high protection against wear and corrosion	- General engineering - High loads

4.4 Lubrication methods

SNR linear axes can be supplied with lubricant by manual grease guns or by central lubrication systems.

4.4.1. Manual grease gun

When using manual grease guns (Figure 4.1), the guiding and drive elements of the Linear Axis are lubricated by the mounted grease nipple.



Figure 4.1 SNR Manual grease gun

Experts
& Tools

4.4.2. Automatic electro-mechanical lubricator DRIVE BOOSTER

The grease nipples of SNR linear axes of the AXE series can be replaced by connections for a central lubrication system (Chapter 6.6).

A suitable central lubrication system is the CONTROL BOOSTER (Figure 4.2). The CONTROL BOOSTER has six connectors for lubricant lines, which can be configured individually and optionally equipped with 250 cc and 500 cc volume of lubricant in the CONTROL REFILL unit. The CONTROL REFILL unit can be replaced after emptying or refilled by the factory.

Experts
& Tools



Figure 4.2 CONTROL BOOSTER

For further information, please contact our application engineers.

4.5 Lubrication points

Depending on the size and drive type, SNR linear axes have a different number of lubrication points in various positions.

AXE60Z, AXE80Z, AXE100Z

The linear axes AXE60Z, AXE80Z and AXE100Z are equipped with a grease nipple on both front sides of the slider unit (Figure 4.3) to ensure best possible accessibility. This means that in each lubrication interval the amount of lubricant given in Chapter 4.6 must be filled on one side of the linear axis into the appropriate grease nipple only. The grease nipples mounted are hydraulic type grease nipples.

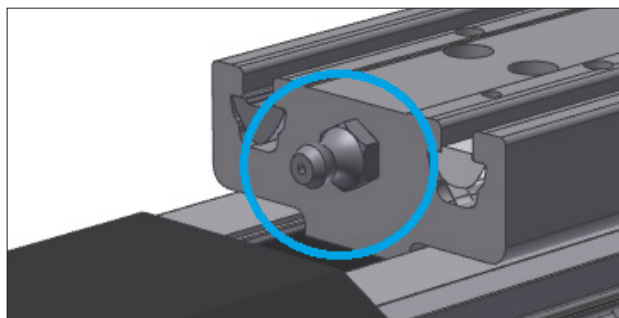

Figure 4.3 Lubrication points for AXE60Z, AXE80Z, AXE100Z

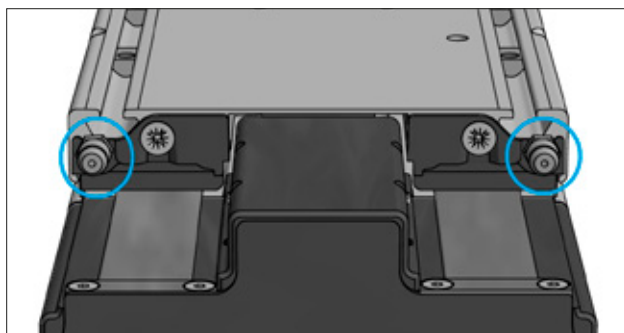

Figure 4.4 Lubrication points for AXE110Z, AXE160Z

AXE110Z, AXE160Z

The linear axis AXE110Z has two grease nipples on the deflection side and the linear axis AXE160Z two grease nipples each at both front sides of the slider unit (Figure 4.4) to ensure best possible accessibility. This means that in each lubrication interval the amount of lubricant given in Chapter 4.6 must be filled on one side of the linear axis into both grease nipples only. The grease nipples mounted are hydraulic type grease nipples.

AXE40A, AXE60A

The linear axes AXE40A and AXE60A are equipped with a grease nipple on the drive head sides (Figure 4.5) to ensure best possible accessibility. This means that in each lubrication interval the amount of lubricant given in Chapter 4.6 must be filled on one side of the linear axis into both grease nipples only. The grease nipples mounted are cup head grease nipples.

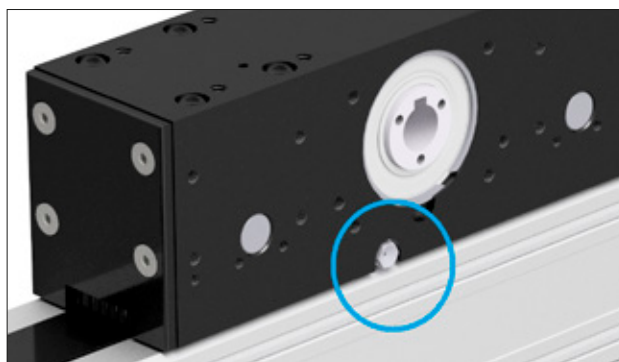

Figure 4.5 Lubrication points for AXE40A, AXE60A

4.6 Amounts of lubricant

The following table contains details on the corresponding amounts of lubricant for re-lubrication using the standard lubricant for the guiding elements.

The amounts of the lubricant for re-lubrication of linear axes with linear guides are summarized in Table 4.2.

Table 4.2 Lubrication amount of the linear guides

Type	Lubrication amount per lubrication point [cm ³]		
	B	C	D
AXE_Z			
AXE60Z	1.0		
AXE80Z	2.8		
AXE100Z		2.4	
AXE110Z			0.6
AXE160Z			2.8
AXE_A			
AXE40A	0.3		
AXE60A	1.0		

4.7 Lubrication intervals

Delivery condition

SNR linear axes are already provided with initial lubrication on delivery. After assembly, the linear axes should be lubricated as outlined in the previous chapters. For optimum grease distribution in the system, this process should take place in two to three steps with intermediate movement over a longer stroke.

When restarting the system after a prolonged shutdown, re-lubrication with twice the amount of lubricant as specified in Chapter 4.6 is recommended.

When the lubricant brand is changed at any time during system operation, it is necessary to verify the miscibility of the lubricants.

Influence factors

The lubrication intervals are influenced by many factors (Chapter 4.2). The biggest influence factors usually are the load and the actual contamination. The exact lubrication intervals can only be determined after testing under real operating conditions and assessment over a sufficiently long period for a specific application.

In Table 4.3 the types of usability of the different linear axes for various degrees of pollution are summarized.

Table 4.3 Degrees of pollution for Linear Axis

Degree of pollution	Application area	Usable Linear Axis AXE
Without pollution	- Laboratories - very clean working areas	all
Low level of pollution	- Assembling areas with very low occurrence of dust and dirt	all
Medium level of pollution	- Production areas and machines with higher occurrence of dirt	only AXE110 and AXE160

The lubrication intervals of the linear guides are shown in the diagram of Figure 4.6, depending on the contamination. As lubricant manufacturers give no general guarantee for the service life time of their products, we recommend a re-greasing intervals of at least 12 months for low kilometrages.

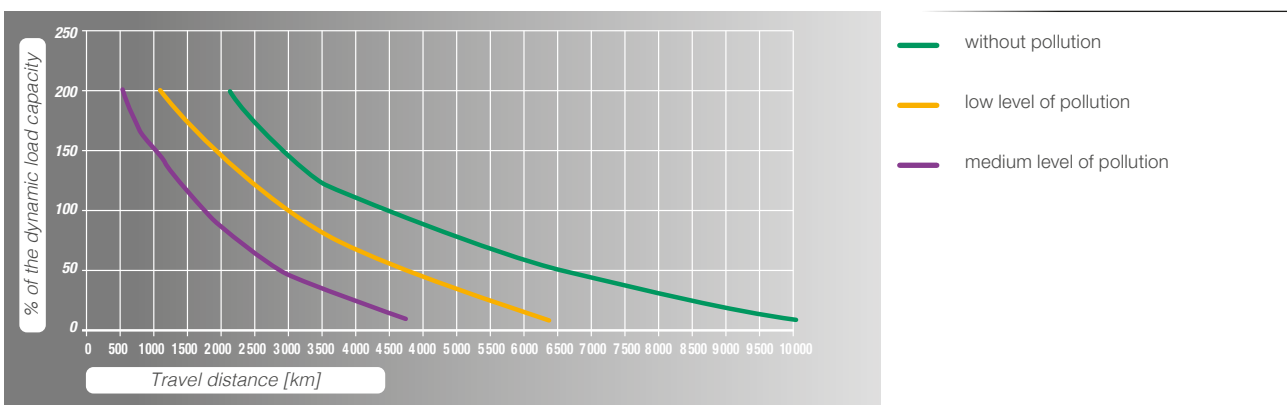

Figure 4.6 Re-lubrication intervals of Linear Guides

If necessary, longer lubrication intervals are possible, after consultation with the lubricant manufacturer for a defined application.

For re-lubrication, mineral oil-based lithium soap greases KP2-K according to DIN 51825 and NLGI class 2 are to be used; otherwise, the compatibility must be checked.

Greases containing solid additives (for example, graphite or MoS₂) must not be used.

4.8 Cover strip replacement

4.8.1. Cover strip replacement for the linear axes AXE110 and AXE160

For the replacement of the cover strip for linear axes AXE110Z and AXE160Z, the following issues must be observed (Figure 4.7):

1. Disassemble the fastening screws **2** and end plate **1**.
2. Disassemble the grease nipple **3**. Remove the washer **4** and the cover strip deflection **5**.
3. Disassemble the fastening screws **6** and remove the clamping plate **7**.
4. Pull out the cover strip **8** out and replace it by a new one.
5. To fasten, tighten the cover slightly and follow the steps 2 and 3 in reverse order. Here the cover strip should not rub against the table. This can be checked by inspection holes in the base of the table grooves (closed with plastic caps). Cut the cover strip **8** behind the clamping plate **7**.
6. Close the linear axis with the end plate **1**.

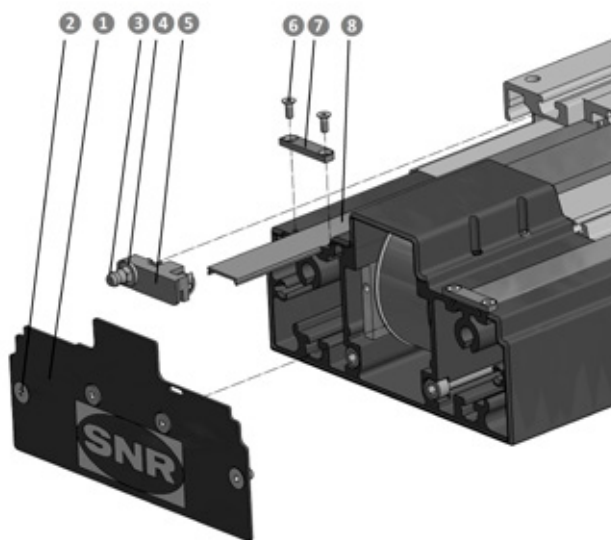

Figure 4.7 Cover strip replacement

4.9 Wear parts sets

For linear axes of the AXE series wear parts sets are available. Table 4.6 summarizes the wear parts sets and the cover strips with ID numbers.

The length of the cover strips is specified in millimeters. To mount the cover strip securely, the ordered length per side should be about 200 to 300 mm longer than the linear axis. The ordered length of cover strips is rounded up to the next full meter. Two cover strips are required for each axis.

The cover strips for linear axes of the AXE series can be applied universally.

Table 4.6 Wear part sets and cover strips

Type code	Designation	ID Number
AX-SP-110-A-WPS	Wear part set for AXE110Z	268344
AX-SP-160-A-WPS	Wear part set for AXE160Z	268345
AX-SP-CST-U-19,0-1M	Cover strip, 1 m	459772
AX-SP-CST-U-19,0-2M	Cover strip, 2 m	461092
AX-SP-CST-U-19,0-3M	Cover strip, 3 m	461093
AX-SP-CST-U-19,0-4M	Cover strip, 4 m	461094
AX-SP-CST-U-19,0-5M	Cover strip, 5 m	461096
AX-SP-CST-U-19,0-6M	Cover strip, 6 m	461097
AX-SP-CST-U-19,0-7M	Cover strip, 7 m	461098

5. SNR linear axes AXE

5.1 General view

5.1.1. Series

The linear axes from the AXE series combine user-oriented product development and high-quality requirements. Due to individual configurability, the user obtains optimal solutions for requirements in all sectors of industry. In the following the most significant features of the series are summarized.

Efficiency line axis AXE_Z

- Universal, usable as single axis or in combination with other axes as linear axes (Figure 5.1)
- Various combinations within the AXE series thanks to standard connecting elements
- Light and highly rigid aluminum profile as base material
- 5 standard sizes from 60 mm up to 160 mm profile width
- Low wear toothed belt drive
- Pulley screwed coupling for force-fitted torque transmission for highest dynamic performance (permanent clearance and wear-free connection)
- Service friendly design with access to all lubrication points on the slider units

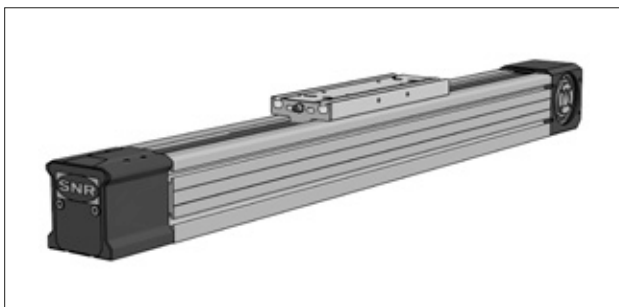
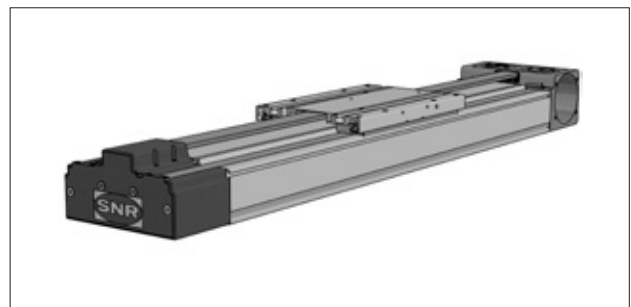

Figure 5.1 AXE with toothed belt drive



Efficiency line axis AXE_A

- Compact linear axis for the use as lifting axis for low and medium loads (Figure 5.2)
- High dynamics by low moving net mass
- Light and highly rigid aluminum profiles as base material
- 2 standard sizes from 40 mm to 60 mm profile width
- Low wear toothed belt drive
- Pulley screwed coupling for force-fitted torque transmission for the highest dynamic performance (permanent clearance and wear-free connection)
- Service friendly design with access to all lubrication points on both sides of the drive head units

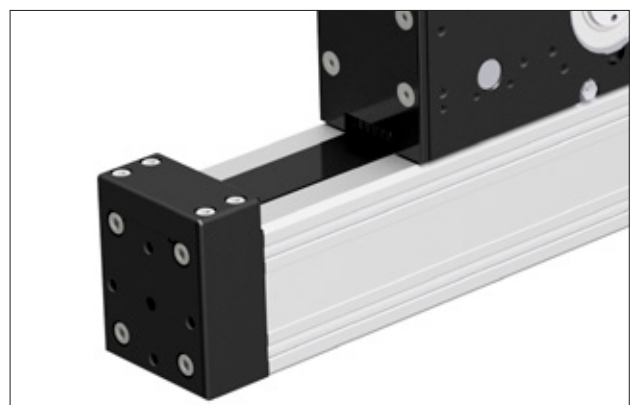

Figure 5.2 AXF with toothed belt / Ω -drive

5.1.2. Main parameters

Linear axes with toothed belt drive

Table 5.1 Main parameters linear axes with toothed belt drive

Type	Axis cross section [mm]	Feed constant [mm/rev.]	Allowable dynamic operating load [N]	Guiding system	Maximum velocity [m/s]	Maximum total length [mm]	Maximum dynamic load capacity [N]		Maximum dynamic load moments [Nm]		
							F _y	F _z	M _x	M _y	M _z
AXE60Z	60 x 80	150	560	B	5	6 120	2 820	2 820	19.5	127	127
AXE80Z	80 x 100	200	870	B	5	8 140	3 600	3 600	33.7	241	241
AXE100Z	100 x 125	264	2 200	C	5	8 120	5 050	5 050	54	707	707
AXE110Z	110 x 65	170	980	D	5	4 096	2 300	2 300	80	110	110
AXE160Z	160 x 83	216	1 830	D	5	6 110	6 000	9 000	475	475	475

Linear Axis with toothed belt / Ω - drive

Table 5.2 Main parameters linear axes with toothed belt / Ω - drive

Type	Axis cross section [mm]	Feed constant [mm/rev.]	Allowable dynamic operating load [N]	Guiding system	Maximum velocity [m/s]	Maximum total length [mm]	Maximum dynamic load capacity [N]		Maximum dynamic load moments [Nm]		
							F _y	F _z	M _x	M _y	M _z
AXE40A	40 x 55,8	75	210	B	5	1 020	500	500	2.4	20	20
AXE60A	60 x 72,7	150	560	B	5	3 868	2 800	2 800	19	100	100

5.2 AXE Efficiency line axes with toothed belt drive

5.2.1. Structure

- ① Drive head
- ② Toothed belt
- ③ Guiding system
- ④ Slider unit
- ⑤ Profile
- ⑥ Deflection head

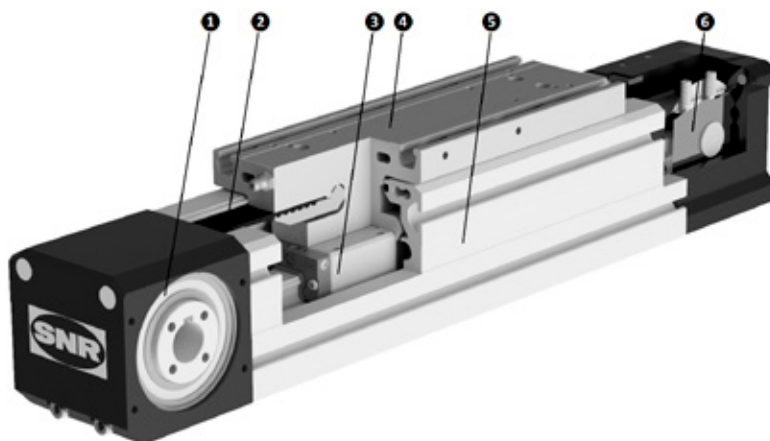

Figure 5.3 Structure AXE60Z, AXE80Z, AXE100Z

- ① Drive head
- ② Toothed belt
- ③ Guiding system
- ④ Slider unit
- ⑤ Profile
- ⑥ Deflection head

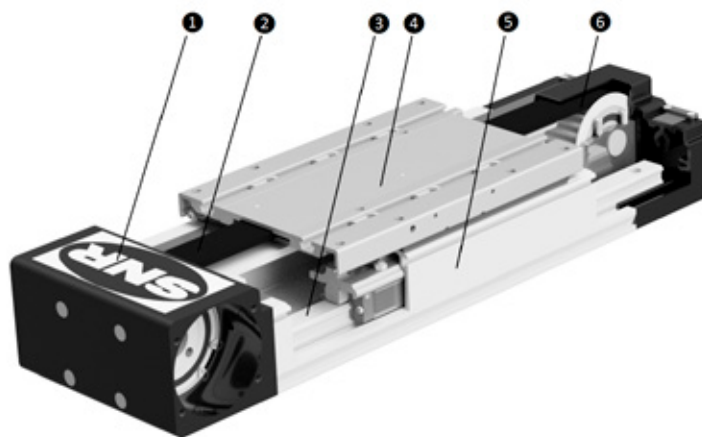
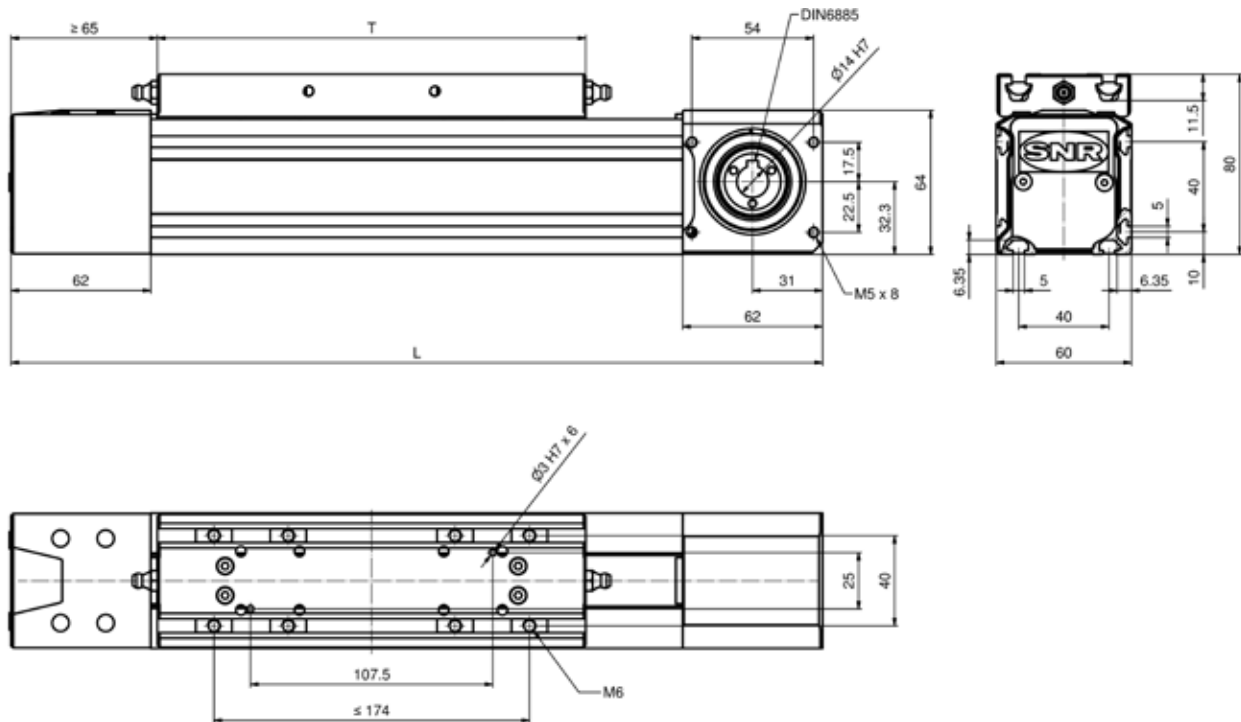

Figure 5.4 Structure AXE110Z, AXE160Z

5.2.2. Dimension / Technical data

AXE60Z



T = Table length

S = Stroke

L = T + S + 127 mm

Technical data

Guiding system		Linear Guide B
Table length T	mm	190
Drive element		Toothed belt 25AT5
Maximum velocity	m/min	300
Permissible dynamic operation load	N	560
Stroke per revolution	mm	150 ^{+0,3}
Idling speed torque	Nm	0.8
Maximum drive torque	Nm	13.4
Moment of inertia ¹	Kgcm ²	0.74
Geometrical moment of inertia (profile) I _y	cm ⁴	40.04
Geometrical moment of inertia (profile) I _z	cm ⁴	60.64
Maximum total length	mm	6 120
Repeatability	mm	0.05

¹ Moment of inertia without gearbox

Dimensions and masses

Type	ID Number	Stroke S [mm]	Total length L [mm]	Mass [kg]
AXE60Z14-B-0040	450076	0040	360	3.1
AXE60Z14-B-0100	450079	0100	420	3.4
AXE60Z14-B-0160	450083	0160	480	3.7
AXE60Z14-B-0220	450084	0220	540	4.0
AXE60Z14-B-0280	450086	0280	600	4.3
AXE60Z14-B-0340	450087	0340	660	4.6
AXE60Z14-B-0400	450088	0400	720	4.9
AXE60Z14-B-0460	450090	0460	780	5.3
AXE60Z14-B-0520	450091	0520	840	5.6
AXE60Z14-B-0580	450092	0580	900	5.9
AXE60Z14-B-0640	450093	0640	960	6.2
AXE60Z14-B-0700	450094	0700	1020	6.5
AXE60Z14-B-0760	450095	0760	1080	6.8
AXE60Z14-B-0820	450096	0820	1140	7.1
AXE60Z14-B-0880	450108	0880	1200	7.4
AXE60Z14-B-0940	450109	0940	1260	7.7
AXE60Z14-B-1000	450110	1000	1320	8.0
AXE60Z14-B-1060	450111	1060	1380	8.3
AXE60Z14-B-1120	450112	1120	1440	8.6
AXE60Z14-B-1180	450113	1180	1500	8.9
AXE60Z14-B-1240	450114	1240	1560	9.2
AXE60Z14-B-1300	450115	1300	1620	9.5
AXE60Z14-B-1360	450116	1360	1680	9.8
AXE60Z14-B-1420	450117	1420	1740	10.1
AXE60Z14-B-1480	450118	1480	1800	10.4
AXE60Z14-B-1540	450119	1540	1860	10.7
AXE60Z14-B-1600	450120	1600	1920	11.0
AXE60Z14-B-1660	450121	1660	1980	11.3
AXE60Z14-B-1720	450122	1720	2040	11.6
AXE60Z14-B-1780	450123	1780	2100	11.9
AXE60Z14-B-1900	450124	1900	2220	12.5
AXE60Z14-B-2020	450125	2020	2340	13.1
AXE60Z14-B-2140	450126	2140	2460	13.7
AXE60Z14-B-2260	450127	2260	2580	14.3
AXE60Z14-B-2380	450128	2380	2700	15.0
AXE60Z14-B-2500	450129	2500	2820	15.6
AXE60Z14-B-2620	450130	2620	2940	16.2
AXE60Z14-B-2740	450131	2740	3060	16.8
AXE60Z14-B-2860	450132	2860	3180	17.4
AXE60Z14-B-3100	450133	3100	3420	18.6
AXE60Z14-B-3340	450134	3340	3660	19.8
AXE60Z14-B-3580	450136	3580	3900	21.0
AXE60Z14-B-3820	450137	3820	4140	22.2
AXE60Z14-B-4060	450138	4060	4380	23.4
AXE60Z14-B-4300	450140	4300	4620	24.7
AXE60Z14-B-4600	450141	4600	4920	26.2
AXE60Z14-B-4900	450142	4900	5220	27.7
AXE60Z14-B-5200	450143	5200	5520	29.2
AXE60Z14-B-5500	450144	5500	5820	30.7
AXE60Z14-B-5800	450145	5800	6120	32.2

AXE80Z

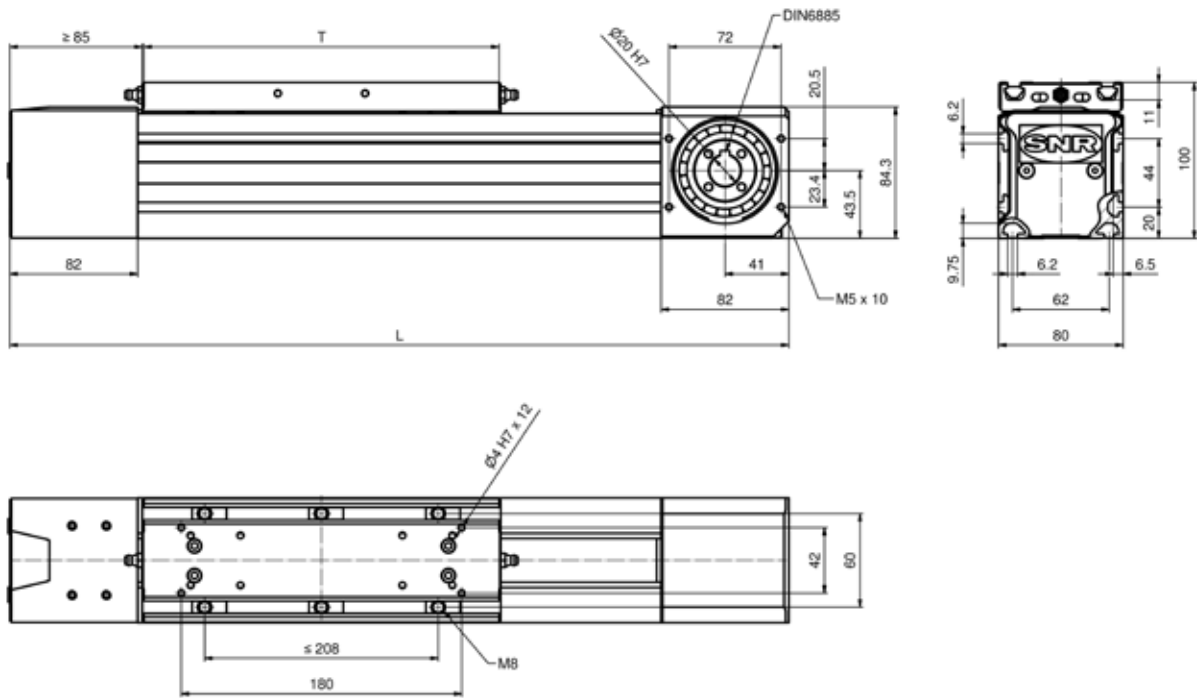

T = Table length

S = Stroke

L = T + S + 167 mm

Technical data

Guiding system		Linear Guide B
Table length T	mm	230
Drive element		Toothed belt 32AT5
Maximum velocity	m/min	300
Permissible dynamic operation load	N	870
Stroke per revolution	mm	200 ^{+0.4}
Idling speed torque	Nm	1.6
Maximum drive torque	Nm	27.7
Moment of inertia ¹	Kgcm ²	3.68
Geometrical moment of inertia (profile) I _y	cm ⁴	146.9
Geometrical moment of inertia (profile) I _z	cm ⁴	199.2
Maximum total length	mm	8 140
Repeatability	mm	0.05

¹ Moment of inertia without gearbox

Dimensions and masses

Type	ID Number	Stroke S [mm]	Total length L [mm]	Mass [kg]
AXE80Z20-B-0060	450236	0060	460	7.2
AXE80Z20-B-0120	450237	0120	520	7.8
AXE80Z20-B-0180	450241	0180	580	8.3
AXE80Z20-B-0240	450242	0240	640	8.9
AXE80Z20-B-0300	450243	0300	700	9.4
AXE80Z20-B-0360	450244	0360	760	10.0
AXE80Z20-B-0420	450245	0420	820	10.5
AXE80Z20-B-0480	450246	0480	880	11.1
AXE80Z20-B-0540	450247	0540	940	11.6
AXE80Z20-B-0600	450251	0600	1000	12.2
AXE80Z20-B-0660	450252	0660	1060	12.7
AXE80Z20-B-0720	450253	0720	1120	13.3
AXE80Z20-B-0780	450254	0780	1180	13.8
AXE80Z20-B-0840	450255	0840	1240	14.4
AXE80Z20-B-0900	450256	0900	1300	14.9
AXE80Z20-B-0960	450257	0960	1360	15.5
AXE80Z20-B-1020	450258	1020	1420	16.0
AXE80Z20-B-1080	450259	1080	1480	16.6
AXE80Z20-B-1140	450260	1140	1540	17.1
AXE80Z20-B-1200	450261	1200	1600	17.7
AXE80Z20-B-1260	450262	1260	1660	18.2
AXE80Z20-B-1320	450263	1320	1720	18.8
AXE80Z20-B-1380	450264	1380	1780	19.3
AXE80Z20-B-1440	450265	1440	1840	19.9
AXE80Z20-B-1500	450266	1500	1900	20.4
AXE80Z20-B-1560	450267	1560	1960	21.0
AXE80Z20-B-1620	450269	1620	2020	21.5
AXE80Z20-B-1680	450270	1680	2080	22.1
AXE80Z20-B-1740	450272	1740	2140	22.6
AXE80Z20-B-1860	450273	1860	2260	23.8
AXE80Z20-B-1980	450274	1980	2380	24.9
AXE80Z20-B-2100	450276	2100	2500	26.0
AXE80Z20-B-2220	450277	2220	2620	27.1
AXE80Z20-B-2340	450279	2340	2740	28.2
AXE80Z20-B-2460	450280	2460	2860	29.3
AXE80Z20-B-2580	450281	2580	2980	30.4
AXE80Z20-B-2700	450282	2700	3100	31.5
AXE80Z20-B-2820	450283	2820	3220	32.6
AXE80Z20-B-3060	450284	3060	3460	34.8
AXE80Z20-B-3300	450285	3300	3700	37.0
AXE80Z20-B-3540	450287	3540	3940	39.2
AXE80Z20-B-3780	410927	3780	4180	41.4
AXE80Z20-B-4020	450290	4020	4420	43.6
AXE80Z20-B-4260	450292	4260	4660	45.8
AXE80Z20-B-4500	450293	4500	4900	48.0
AXE80Z20-B-4800	450294	4800	5200	50.7
AXE80Z20-B-5100	450295	5100	5500	53.5
AXE80Z20-B-5400	450296	5400	5800	56.2
AXE80Z20-B-5700	450297	5700	6100	59.0
AXE80Z20-B-6000	450298	6000	6400	61.7
AXE80Z20-B-6600	450299	6600	7000	67.2
AXE80Z20-B-7200	450300	7200	7600	72.7
AXE80Z20-B-7680	450301	7680	8080	77.1

AXE100Z

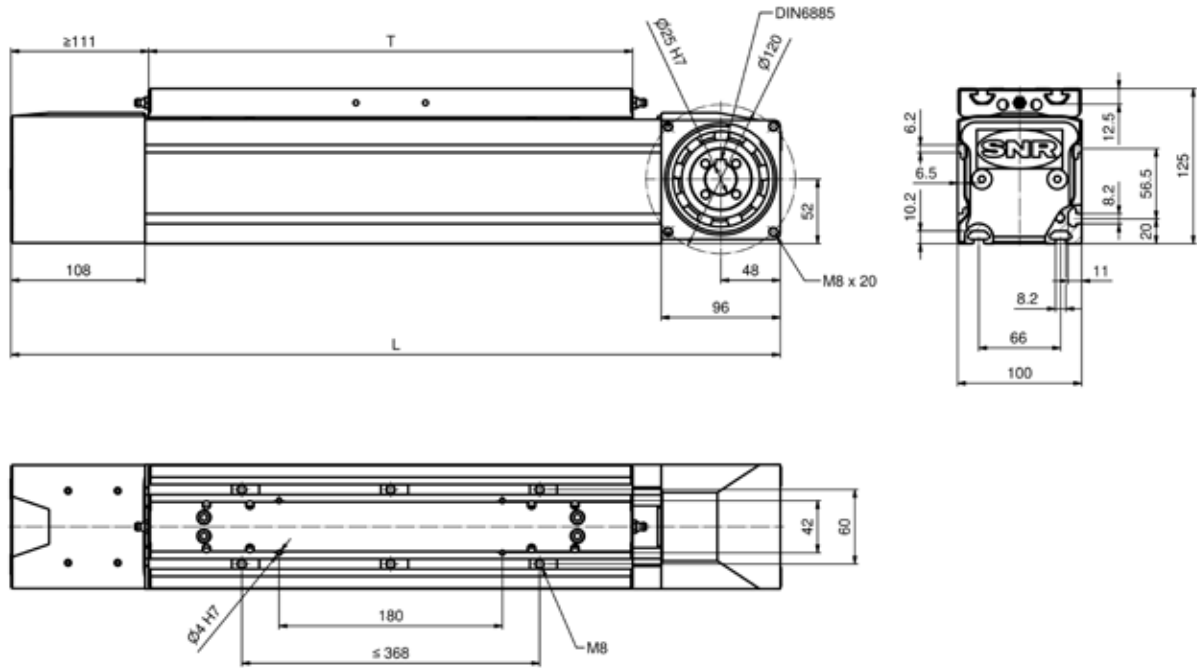

T = Table length

S = Stroke

L = T + S + 207 mm

Technical data

Guiding system		Linear Guide C
Table length T	mm	390
Drive element		Toothed belt 40STD8
Maximum velocity	m/min	300
Permissible dynamic operation load	N	2 200
Stroke per revolution	mm	264 ^{+0.5}
Idling speed torque	Nm	3.1
Maximum drive torque	Nm	92.6
Moment of inertia ¹	Kgcm ²	14.3
Geometrical moment of inertia (profile) I _y	cm ⁴	366.7
Geometrical moment of inertia (profile) I _z	cm ⁴	482.8
Maximum total length	mm	8 120
Repeatability	mm	0.05

¹ Moment of inertia without gearbox

Dimensions and masses

Type	ID Number	Stroke S [mm]	Total length L [mm]	Mass [kg]
AXE100Z25-C-0200	450302	0200	800	18.0
AXE100Z25-C-0260	450303	0260	860	18.9
AXE100Z25-C-0320	450304	0320	920	19.8
AXE100Z25-C-0380	450305	0380	980	20.6
AXE100Z25-C-0440	450312	0440	1040	21.5
AXE100Z25-C-0500	450314	0500	1100	22.4
AXE100Z25-C-0560	450316	0560	1160	23.3
AXE100Z25-C-0620	450317	0620	1220	24.2
AXE100Z25-C-0680	450318	0680	1280	25.1
AXE100Z25-C-0740	450320	0740	1340	26.0
AXE100Z25-C-0800	450321	0800	1400	26.9
AXE100Z25-C-0860	450322	0860	1460	27.8
AXE100Z25-C-0920	450323	0920	1520	28.7
AXE100Z25-C-0980	450369	0980	1580	29.6
AXE100Z25-C-1040	450371	1040	1640	30.5
AXE100Z25-C-1100	450372	1100	1700	31.3
AXE100Z25-C-1160	450374	1160	1760	32.2
AXE100Z25-C-1220	450377	1220	1820	33.1
AXE100Z25-C-1280	450381	1280	1880	34.0
AXE100Z25-C-1340	450382	1340	1940	34.9
AXE100Z25-C-1400	450383	1400	2000	35.8
AXE100Z25-C-1460	450384	1460	2060	36.7
AXE100Z25-C-1520	450385	1520	2120	37.6
AXE100Z25-C-1580	450386	1580	2180	38.5
AXE100Z25-C-1700	450387	1700	2300	40.3
AXE100Z25-C-1820	450388	1820	2420	42.0
AXE100Z25-C-1940	450389	1940	2540	43.8
AXE100Z25-C-2060	450390	2060	2660	45.6
AXE100Z25-C-2180	450391	2180	2780	47.4
AXE100Z25-C-2300	450392	2300	2900	49.2
AXE100Z25-C-2420	450393	2420	3020	51.0
AXE100Z25-C-2540	450394	2540	3140	52.7
AXE100Z25-C-2660	450395	2660	3260	54.5
AXE100Z25-C-2900	450396	2900	3500	58.1
AXE100Z25-C-3140	450397	3140	3740	61.7
AXE100Z25-C-3380	450398	3380	3980	65.2
AXE100Z25-C-3620	410929	3620	4220	68.8
AXE100Z25-C-3860	450400	3860	4460	72.4
AXE100Z25-C-4100	450402	4100	4700	75.9
AXE100Z25-C-4400	450406	4400	5000	80.4
AXE100Z25-C-4700	450409	4700	5300	84.8
AXE100Z25-C-5000	450410	5000	5600	89.3
AXE100Z25-C-5300	450412	5300	5900	93.7
AXE100Z25-C-5600	450413	5600	6200	98.2
AXE100Z25-C-5900	450414	5900	6500	102.7
AXE100Z25-C-6500	450415	6500	7100	111.6
AXE100Z25-C-7100	450416	7100	7700	120.5
AXE100Z25-C-7520	450417	7520	8120	126.7

AXE100Z

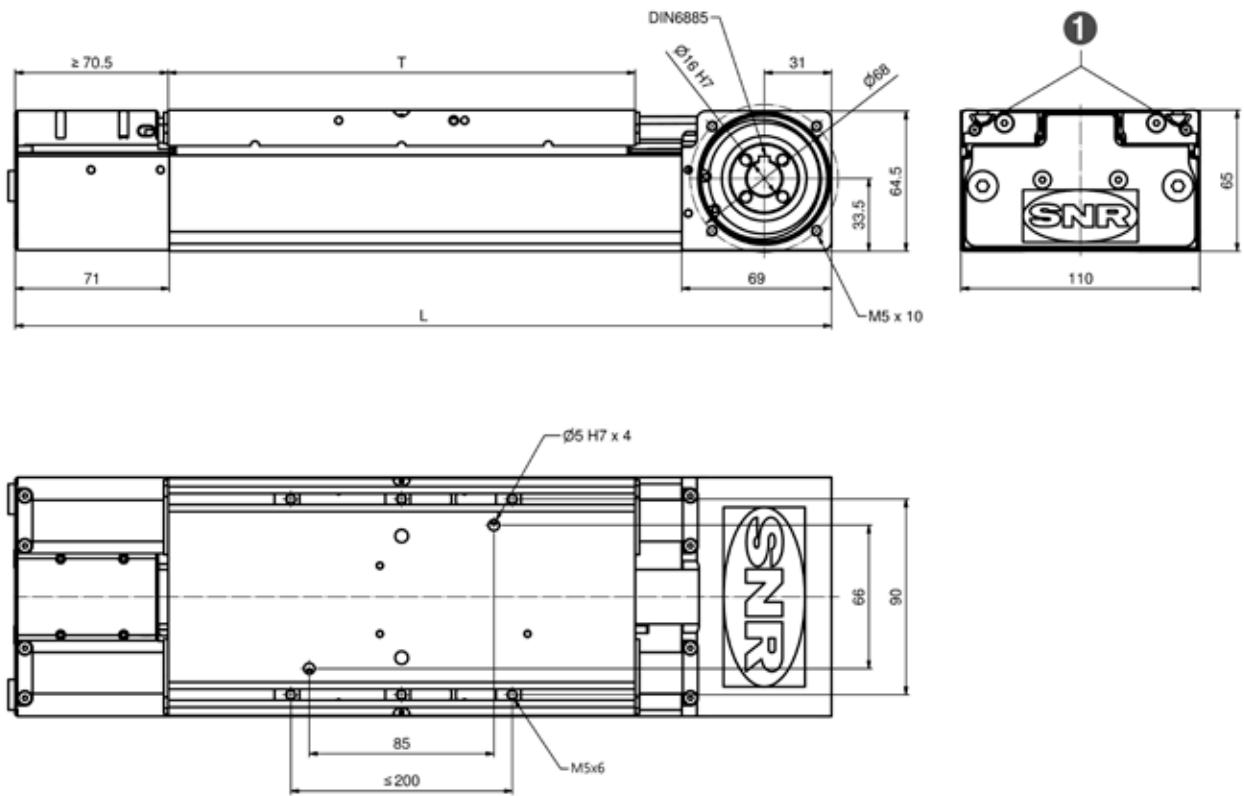

T = Table length

S = Stroke

L = T + S + 139,5 mm

① Re-greasing possibility on both sides

Technical data

Guiding system		Linear Guide D
Table length T	mm	215
Distance of the sliding blocks L1		≤ 200 mm (recommended 100 mm)
Drive element		Toothed belt 25STD5
Maximum velocity	m/min	300
Permissible dynamic operation load	N	980
Stroke per revolution	mm	170 ^{+0.5}
Idling speed torque	Nm	1.7
Maximum drive torque	Nm	26.5
Moment of inertia ¹	Kgcm ²	1.4
Geometrical moment of inertia (profile) I _y	cm ⁴	37.45
Geometrical moment of inertia (profile) I _z	cm ⁴	138.31
Maximum total length	mm	4 096
Repeatability	mm	0.05

¹ Moment of inertia without gearbox

Dimensions and masses

Type	ID Number	Stroke S [mm]	Total length L [mm]	Mass [kg]
AXE110Z16-D-0080	450440	0080	436	4.6
AXE110Z16-D-0140	450441	0140	496	5.1
AXE110Z16-D-0200	450442	0200	556	5.5
AXE110Z16-D-0260	450443	0260	616	5.9
AXE110Z16-D-0320	450444	0320	676	6.3
AXE110Z16-D-0380	450445	0380	736	6.8
AXE110Z16-D-0440	450446	0440	796	7.2
AXE110Z16-D-0500	450447	0500	856	7.6
AXE110Z16-D-0560	450448	0560	916	8.0
AXE110Z16-D-0620	450450	0620	976	8.5
AXE110Z16-D-0680	450451	0680	1036	8.9
AXE110Z16-D-0740	450452	0740	1096	9.3
AXE110Z16-D-0800	450453	0800	1156	9.7
AXE110Z16-D-0860	450454	0860	1216	10.2
AXE110Z16-D-0920	450455	0920	1276	10.6
AXE110Z16-D-0980	450456	0980	1336	11.0
AXE110Z16-D-1040	450457	1040	1396	11.4
AXE110Z16-D-1100	450459	1100	1456	11.9
AXE110Z16-D-1160	450460	1160	1516	12.3
AXE110Z16-D-1220	450461	1220	1576	12.7
AXE110Z16-D-1280	450462	1280	1636	13.1
AXE110Z16-D-1340	450463	1340	1696	13.6
AXE110Z16-D-1400	450464	1400	1756	14.0
AXE110Z16-D-1460	450465	1460	1816	14.4
AXE110Z16-D-1520	450466	1520	1876	14.8
AXE110Z16-D-1580	450467	1580	1936	15.3
AXE110Z16-D-1640	450477	1640	1890	15.7
AXE110Z16-D-1700	450468	1700	2056	16.1
AXE110Z16-D-1820	450469	1820	2176	16.9
AXE110Z16-D-1940	450470	1940	2296	17.8
AXE110Z16-D-2060	450471	2060	2416	18.6
AXE110Z16-D-2180	450472	2180	2536	19.5
AXE110Z16-D-2300	450473	2300	2656	20.3
AXE110Z16-D-2420	450474	2420	2776	21.2
AXE110Z16-D-2540	450475	2540	2896	22.0
AXE110Z16-D-2660	450476	2660	3016	22.9
AXE110Z16-D-2780	450478	2780	3136	23.7
AXE110Z16-D-3020	450479	3020	3376	25.4
AXE110Z16-D-3260	450480	3260	3616	27.2
AXE110Z16-D-3500	450481	3500	3856	28.9
AXE110Z16-D-3740	410930	3740	4096	30.6

AXE160Z

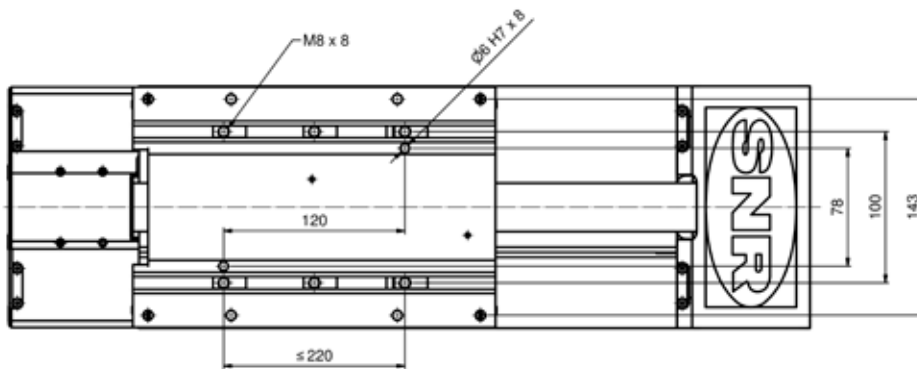
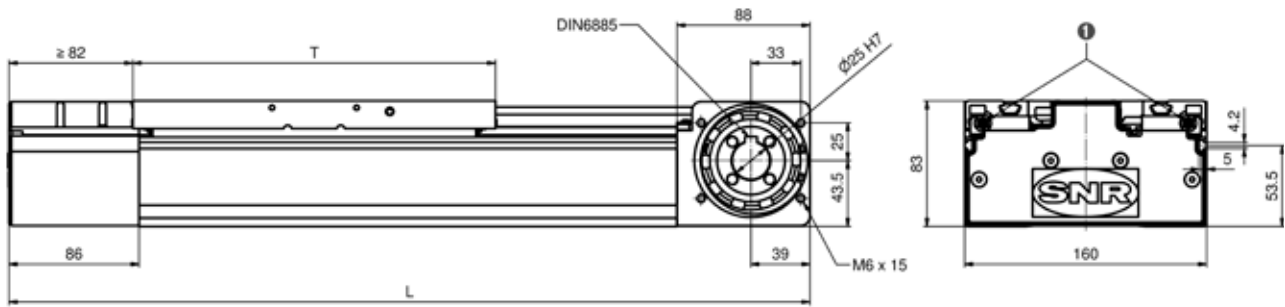

T = Table length

S = Stroke

L = T + S + 170 mm

① Re-greasing possibility on both sides

Technical data

Guiding system		Linear Guide D
Table length T	mm	240
Distance of the sliding blocks L1		≤ 220 mm (recommended 120 mm)
Drive element		Toothed belt 32STD8
Maximum velocity	m/min	300
Permissible dynamic operation load	N	1 830
Stroke per revolution	mm	216 ^{+0.5}
Idling speed torque	Nm	3.6
Maximum drive torque	Nm	62.9
Moment of inertia ¹	Kgcm ²	5.8
Geometrical moment of inertia (profile) I _y	cm ⁴	140.29
Geometrical moment of inertia (profile) I _z	cm ⁴	666.80
Maximum total length	mm	6 110
Repeatability	mm	0.05

¹ Moment of inertia without gearbox

Dimensions and masses

Type	ID Number	Stroke S [mm]	Total length L [mm]	Mass [kg]
AXE160Z25-D-0120	450487	0120	530	11.8
AXE160Z25-D-0180	450488	0180	590	12.6
AXE160Z25-D-0240	450496	0240	650	13.3
AXE160Z25-D-0300	450497	0300	710	14.1
AXE160Z25-D-0360	450498	0360	770	14.8
AXE160Z25-D-0420	450499	0420	830	15.6
AXE160Z25-D-0480	450500	0480	890	16.3
AXE160Z25-D-0540	450501	0540	950	17.1
AXE160Z25-D-0600	450502	0600	1010	17.9
AXE160Z25-D-0660	450503	0660	1070	18.6
AXE160Z25-D-0720	450504	0720	1130	19.4
AXE160Z25-D-0780	450505	0780	1190	20.1
AXE160Z25-D-0840	450506	0840	1250	20.9
AXE160Z25-D-0900	450508	0900	1310	21.6
AXE160Z25-D-0960	450509	0960	1370	22.4
AXE160Z25-D-1020	450510	1020	1430	23.1
AXE160Z25-D-1080	450511	1080	1490	23.9
AXE160Z25-D-1140	450512	1140	1550	24.6
AXE160Z25-D-1200	450513	1200	1610	25.4
AXE160Z25-D-1260	450514	1260	1670	26.2
AXE160Z25-D-1320	450515	1320	1730	26.9
AXE160Z25-D-1380	450516	1380	1790	27.7
AXE160Z25-D-1440	450517	1440	1850	28.4
AXE160Z25-D-1500	450518	1500	1910	29.2
AXE160Z25-D-1560	450520	1560	1970	29.9
AXE160Z25-D-1620	450521	1620	2030	30.7
AXE160Z25-D-1680	450522	1680	2090	31.4
AXE160Z25-D-1800	450524	1800	2210	32.9
AXE160Z25-D-1920	450526	1920	2330	34.5
AXE160Z25-D-2040	450527	2040	2450	36.0
AXE160Z25-D-2160	450528	2160	2570	37.5
AXE160Z25-D-2280	450529	2280	2690	39.0
AXE160Z25-D-2400	450530	2400	2810	40.5
AXE160Z25-D-2520	450531	2520	2930	42.0
AXE160Z25-D-2640	450533	2640	3050	43.5
AXE160Z25-D-2760	450536	2760	3170	45.0
AXE160Z25-D-3000	450537	3000	3410	48.0
AXE160Z25-D-3240	450538	3240	3650	51.1
AXE160Z25-D-3480	450539	3480	3890	54.1
AXE160Z25-D-3720	410935	3720	4130	57.1
AXE160Z25-D-3960	450541	3960	4370	60.1
AXE160Z25-D-4200	450542	4200	4610	63.1
AXE160Z25-D-4500	450543	4500	4910	66.9
AXE160Z25-D-4800	450544	4800	5210	70.7
AXE160Z25-D-5100	450545	5100	5510	74.5
AXE160Z25-D-5400	450546	5400	5810	78.2
AXE160Z25-D-5700	450547	5700	6110	82.0

5.2.3 Maximum static load capacity

Type	Guiding system	Load [N]		Load moment [Nm]		
		F_y	F_z	M_x	M_y	M_z
AXE60Z	B	4 860	9 650	66	420	210
AXE80Z	B	7 900	12 400	115	840	490
AXE100Z	C	11 200	16 500	175	2 100	1 300
AXE110Z	D	7 900	7 900	275	375	375
AXE160Z	D	32 000	32 000	1 600	1 650	1 650

5.2.4 Dynamic load capacity

The dynamic load capacities of the guiding systems are based on a nominal life time of 50 000 km.

Type	Guiding system	Load [N]		Load moment [Nm]		
		F_y	F_z	M_x	M_y	M_z
AXE60Z	B	2 820	2 820	19,5	127	127
AXE80Z	B	4 500	4 500	42,0	300	300
AXE100Z	C	5 050	5 050	54,0	650	650
AXE110Z	D	2 300	2 300	80,0	110	110
AXE160Z	D	9 000	9 000	475	475	475

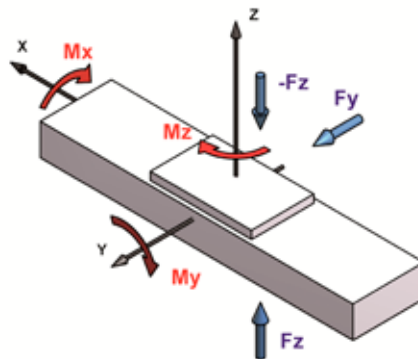

5.3 AXE Efficiency Line axes with toothed belt / Ω - drive

5.3.1 Structure

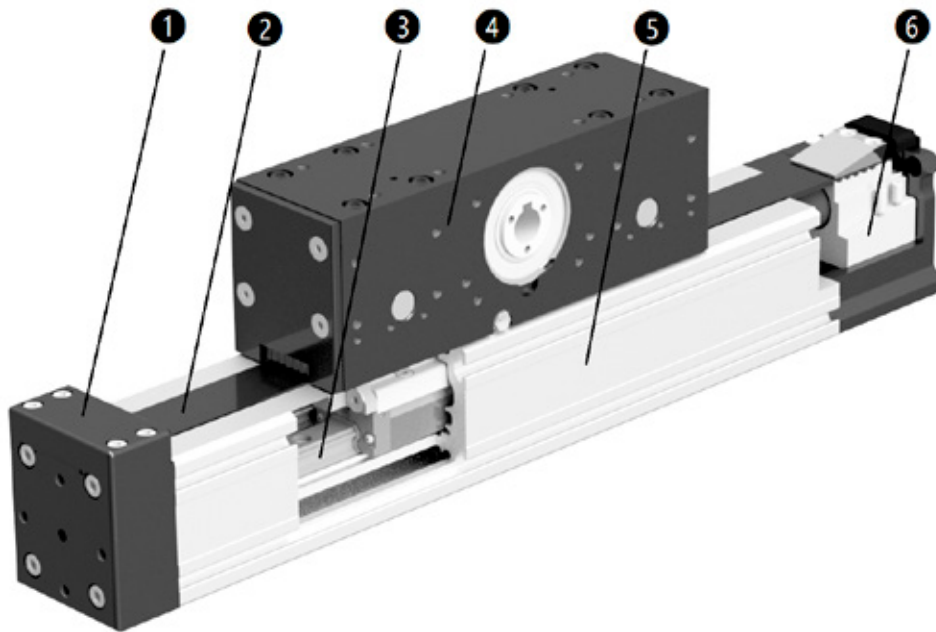
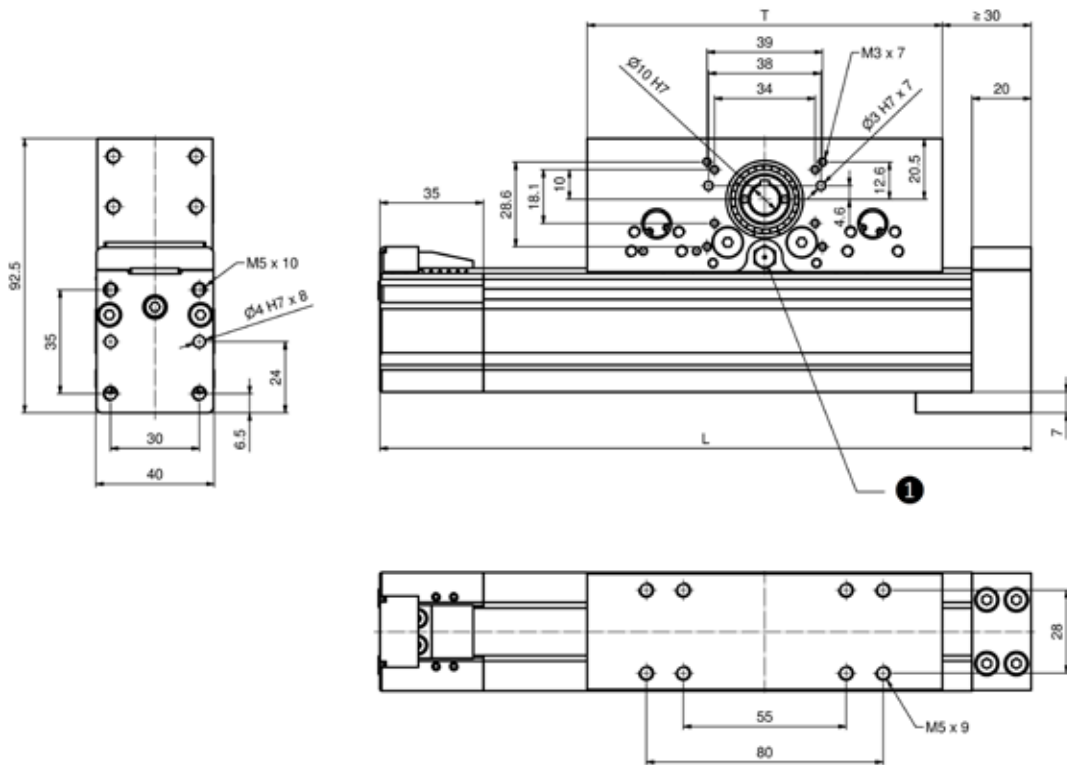

Figure 5.5 Structure AXE_A

- ① Toothed belt clamping
- ② Toothed belt
- ③ Guiding system
- ④ Drive head
- ⑤ Profile
- ⑥ Toothed belt tension unit

5.3.2 Dimensions / Technical data

AXE40A



T = Table length

S = Stroke

L = T + S + 65 mm

① Re-greasing option on both sides

Technical data

Guiding system		Linear Guide B
Table length T	mm	120
Drive element		Toothed belt 16AT3
Maximum velocity	m/min	300
Permissible dynamic operation load	N	210
Stroke per revolution	mm	75 ^{+0,1}
Idling speed torque	Nm	0.2
Maximum drive torque	Nm	2.5
Moment of inertia ¹	Kgcm ²	0.16
Geometrical moment of inertia (profile) I _y	cm ⁴	9.521
Geometrical moment of inertia (profile) I _z	cm ⁴	12.14
Maximum total length	mm	1 020
Repeatability	mm	0.08

¹: Moment of inertia without gearbox

Dimensions and masses

Type	ID Number	Stroke S [mm]	Total length L [mm]	Mass [kg]
AXE40A10-B-0040	450048	40	220	1,4
AXE40A10-B-0060	450050	60	240	1,4
AXE40A10-B-0080	450051	80	260	1,5
AXE40A10-B-0120	450052	120	300	1,6
AXE40A10-B-0160	450053	160	340	1,7
AXE40A10-B-0200	450054	200	380	1,7
AXE40A10-B-0240	450056	240	420	1,8
AXE40A10-B-0280	450057	280	460	1,9
AXE40A10-B-0320	450058	320	500	2,0
AXE40A10-B-0360	450059	360	540	2,1
AXE40A10-B-0400	450062	400	580	2,2
AXE40A10-B-0440	450063	440	620	2,3
AXE40A10-B-0480	450064	480	660	2,4
AXE40A10-B-0520	450065	520	700	2,4
AXE40A10-B-0560	450067	560	740	2,5
AXE40A10-B-0600	450068	600	780	2,6
AXE40A10-B-0640	450069	640	820	2,7
AXE40A10-B-0680	450070	680	860	2,8
AXE40A10-B-0720	450071	720	900	2,9
AXE40A10-B-0760	450072	760	940	3,0
AXE40A10-B-0800	450073	800	980	3,1
AXE40A10-B-0840	450074	840	1020	3,1

AXE60A

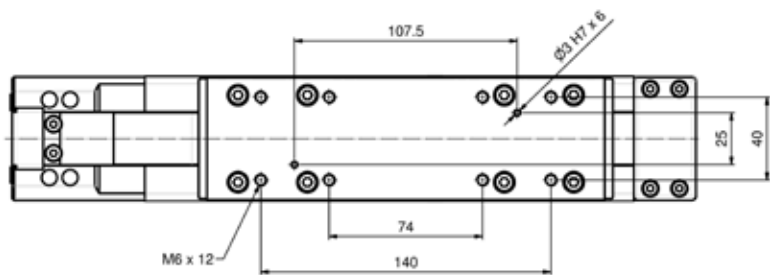
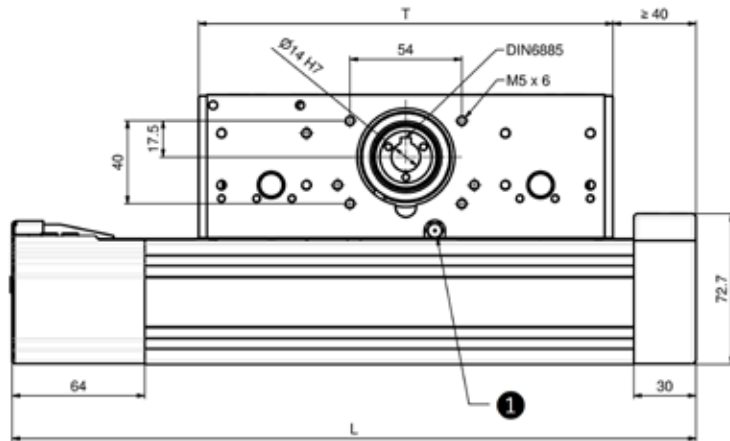
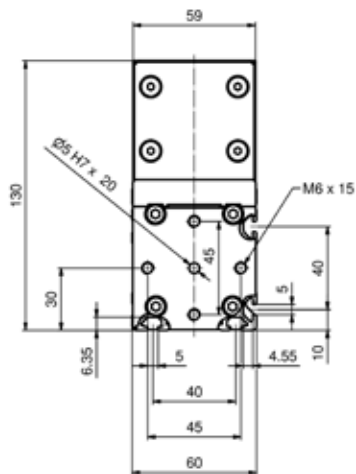

T = Table length

S = Stroke

L = T + S + 104 mm

1 Re-greasing option on both sides

Technical data

Guiding system		Linear Guide B
Table length T	mm	200
Drive element		Toothed belt 25AT5
Maximum velocity	m/min	300
Permissible dynamic operation load	N	560
Stroke per revolution	mm	150 ^{+0.3}
Idling speed torque	Nm	0,8
Maximum drive torque	Nm	13,4
Moment of inertia ¹	Kgcm ²	1,07
Geometrical moment of inertia (profile) I _y	cm ⁴	40,04
Geometrical moment of inertia (profile) I _z	cm ⁴	60,64
Maximum total length	mm	3 868
Repeatability	mm	0,05

¹ Moment of inertia without gearbox

Dimensions and masses

Type	ID Number	Stroke S [mm]	Total length L [mm]	Mass [kg]
AXE60A14-B-0040	450154	0040	328	4.5
AXE60A14-B-0100	450155	0100	388	4.8
AXE60A14-B-0160	450156	0160	448	5.1
AXE60A14-B-0220	450157	0220	508	5.4
AXE60A14-B-0280	450160	0280	568	5.7
AXE60A14-B-0340	450161	0340	628	6.0
AXE60A14-B-0400	450163	0400	688	6.3
AXE60A14-B-0460	450164	0460	748	6.5
AXE60A14-B-0520	450166	0520	808	6.8
AXE60A14-B-0580	450197	0580	868	7.1
AXE60A14-B-0640	450198	0640	928	7.4
AXE60A14-B-0700	450199	0700	988	7.7
AXE60A14-B-0760	450200	0760	1048	8.0
AXE60A14-B-0820	450201	0820	1108	8.3
AXE60A14-B-0880	450202	0880	1168	8.6
AXE60A14-B-0940	450203	0940	1228	8.9
AXE60A14-B-1000	450204	1000	1288	9.2
AXE60A14-B-1060	450206	1060	1348	9.5
AXE60A14-B-1120	450207	1120	1408	9.8
AXE60A14-B-1180	450208	1180	1468	10.1
AXE60A14-B-1240	450209	1240	1528	10.4
AXE60A14-B-1300	450210	1300	1588	10.7
AXE60A14-B-1360	450211	1360	1648	11.0
AXE60A14-B-1420	450212	1420	1708	11.3
AXE60A14-B-1480	450213	1480	1768	11.6
AXE60A14-B-1540	450214	1540	1828	11.9
AXE60A14-B-1600	450215	1600	1888	12.2
AXE60A14-B-1660	450216	1660	1948	12.5
AXE60A14-B-1720	450219	1720	2008	12.7
AXE60A14-B-1780	450220	1780	2068	13.0
AXE60A14-B-1900	450221	1900	2188	13.6
AXE60A14-B-2020	450222	2020	2308	14.2
AXE60A14-B-2140	450223	2140	2428	14.7
AXE60A14-B-2260	450225	2260	2548	15.3
AXE60A14-B-2380	450226	2380	2668	15.9
AXE60A14-B-2500	450228	2500	2788	16.5
AXE60A14-B-2620	450230	2620	2908	17.1
AXE60A14-B-2740	450231	2740	3028	17.7
AXE60A14-B-2860	450232	2860	3148	18.3
AXE60A14-B-3100	450233	3100	3388	19.4
AXE60A14-B-3340	450234	3340	3628	20.6
AXE60A14-B-3580	450235	3580	3868	21.8

5.3.3 Maximum static load capacity

Type	Guiding system	Load [N]		Load moment [Nm]		
		F_y	F_z	M_x	M_y	M_z
AXE40A	B	1 300	1 300	5,9	45	45
AXE60A	B	4 860	9 650	66	350	180

5.3.4 Dynamic load capacity

The dynamic load capacities of the guiding systems are based on a nominal life time of 50 000 km.

Type	Guiding system	Load [N]		Load moment [Nm]		
		F_y	F_z	M_x	M_y	M_z
AXE40A	B	850	850	4	30	30
AXE60A	B	2 800	2 800	19	100	100

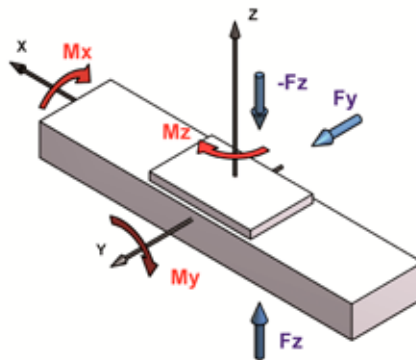

6. Accessories

6.1. Fastening and connecting elements

For the assembly of SNR linear axes of the AXE series a perfectly matched range of fastening elements is available. Sliding blocks, fastening strips and an extensive range of connecting elements offer manifold options to fix the axes on mounting surfaces or to combine these axes.

The following components are available as fastening and connecting elements:

- Fastening strips
- Sliding blocks
- Direct connections
- Cross connections
- Gantry connections
- A – standard connections
- Angle connections

6.1.1. Fastening strips

Fastening strips (Figure 6.1) are available for linear axes of the AXE series.

The distance between the fastening points must be selected according to the load, required straightness and rigidity. The dimensions and type codes, including the ID – Numbers, are specified for linear axes of the AXE series in Figure 6.2 and Table 6.1.

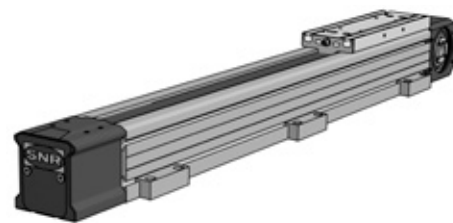

Figure 6.1 Linear axis AXE with fastening strips

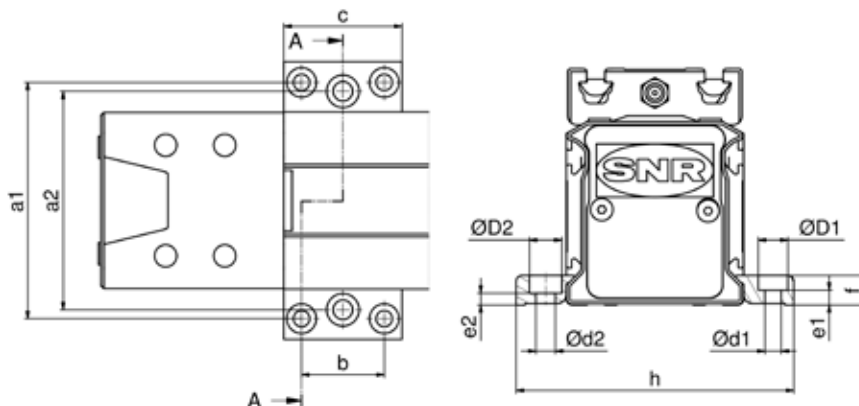

Figure 6.2 Dimension fastening strips AXE

Table 6.1 Fastening strips AXE

Type	Type code	ID number	a1	a2	b	c	d1	D1	e1	d2	D2	e2	f	g	h
			[mm]	[mm]	[mm]	[mm]	[mm]	[mm]	[mm]	[mm]	[mm]	[mm]	[mm]	[mm]	[mm]
AXE40	AX-AC-FST-40x13-2	108663	55		28	40	5.5	10	7.0				13	38	66
AXE601	AX-AC-FST-40x10-3	108579	80	74	28	40	5.5	10	5.0	6,6	11	4	10	48	94
AXE80	AX-AC-FST-70x20-2	108075	94		50	70	6.6	11	14.0				20	76	108
AXE100	AX-AC-FST-78x22-2	110236	116		60	78	9.0	15	11.5				22	108	140
AXE110	AX-AC-FST-47x7-2	150822	126		30	47	5.5	9	3.5				7	69	140
AXE160	AX-AC-FST-68x9-2	150999	174		50	68	6.5	11	3.5				9	88	188

¹- also suitable for standard machine construction profiles spacing 20

6.1.2. Sliding blocks

Different sliding blocks (Figure 6.3) are available for linear axes of the AXE series.

The distance between the sliding blocks must be selected according to the load, required straightness and rigidity. Two different designs of sliding blocks are available. The dimensions and type codes, including the ID - Numbers of the sliding blocks, are specified in Figure 6.4 and Table 6.2.

Design type E / F

- Standard sliding block
- Steel galvanized (stainless steel A2 partly possible)
- Swiveling into any desired position
- Fixation via spring-loaded ball

Design type R

- For effective component mounting
- Zinc die cast
- Pre-assembly on the component for insertion into any position
- Locking by tightening the screw

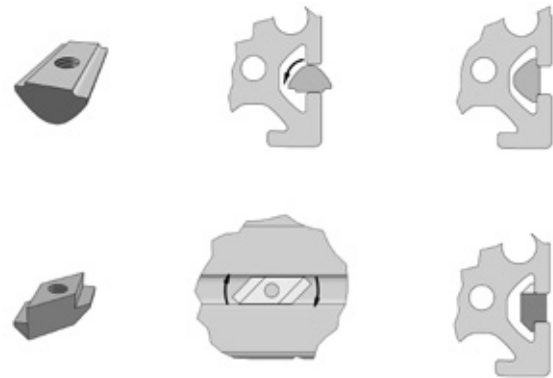

Figure 6.3 Sliding block designs

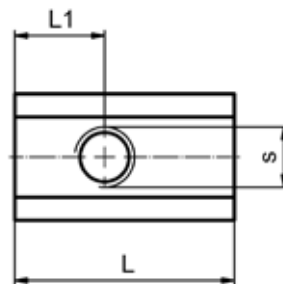

Figure 6.4 Dimension sliding blocks

Table 6.2 Sliding blocks

Type	Type code	ID number	Design type	S	L ¹	L ¹	TA ²	max. tensile force
					[mm]	[mm]	[mm]	[N]
AXE40Z AXE60Z	AX-AC-SBL-5ST-M3-E	109066	E	M3	12	3.0	1.5	500
	AX-AC-SBL-5ST-M4-E	109073	E	M4	12	4.0	3.0	500
	AX-AC-SBL-5ST-M4-E-A2	289073	E	M4	12	4.0	3.0	500
	AX-AC-SBL-5ST-M5-E	109070	E	M5	12	4.0	4.5	500
	AX-AC-SBL-5ST-M5-E-A2	139275	E	M5	12	4.0	4.5	500
AXE80Z	AX-AC-SBL-5-M3-R-Zi	103758	R	M3	5	2.5	1.0	50
	AX-AC-SBL-6ST-M4-E	109094	E	M4	17	5.0	4.0	1 750
	AX-AC-SBL-6ST-M5-E	109093	E	M5	17	5.0	8.0 ³	1 750
	AX-AC-SBL-6ST-M6-E	109091	E	M6	17	5.5	14.0 ³	1 750
	AX-AC-SBL-6ST-M6-E-A2	203392	E	M6	17	5.5	14.0 ³	1 750
AXE100Z (groove laterally above)	AX-AC-SBL-6-M4-R-Zi	103759	R	M4	15	7.5	1.5	150
	AX-AC-SBL-6ST-M4-F	255069	F	M4	16	8.0	4.0 ³	1 750
	AX-AC-SBL-6ST-M5-F	353280	F	M5	16	8.0	8.0 ³	1 750
AXE100Z (groove below and laterally below)	AX-AC-SBL-6ST-M6-F	255070	F	M6	16	8.0	14.0 ³	1 750
	AX-AC-SBL-8ST-M5-F	258785	F	M5	22	7.0	8.0 ³	2 500
	AX-AC-SBL-8ST-M6-F	183942	F	M6	22	7.0	14.0 ³	2 500
	AX-AC-SBL-8ST-M8-F	149812	F	M8	22	7.0	25.0	2 500

¹ Maximum value, deviating dimension possible

² Maximum tightening torque

³ Maximum tightening torque only applies to screws of property class IP 10.9

6.1.3. Direct connections

Direct connections (Figure 6.5) are connecting sets containing all essential connecting elements such as adapter plates, fastening strips, screws...

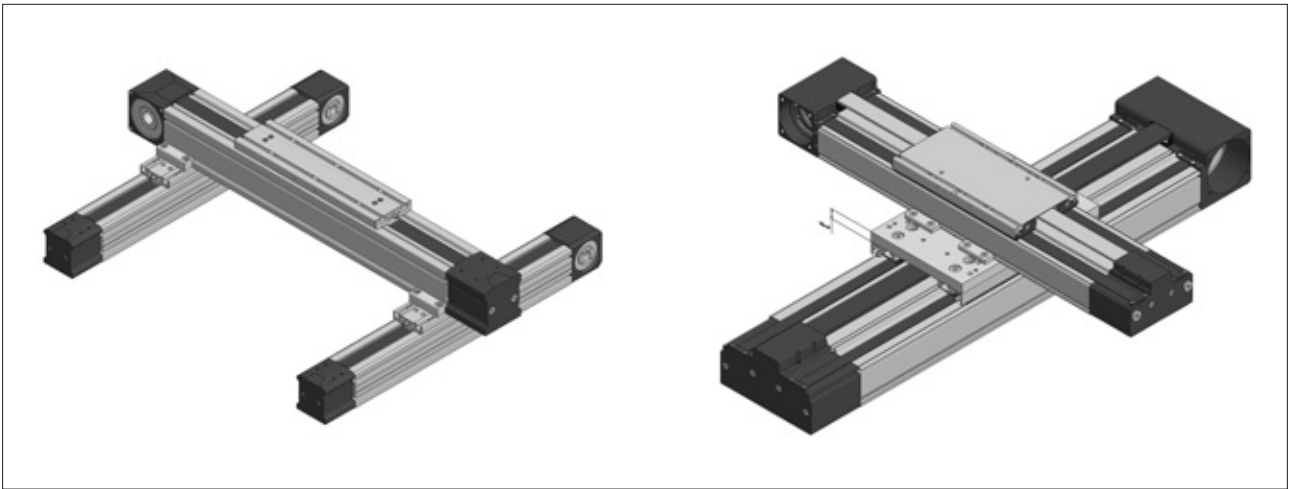

Figure 6.5 Direct connections AXE

The type codes and ID numbers of direct connections are specified in Table 6.3

Table 6.3 Direct connections AXE

		Y - Axis				
		AXE60Z	AXE80Z	AXE100Z	AXE110Z	AXE160Z
X - Axis	AXE60Z	2x AX-AC-DCU-60-60 (ID 230147)			AX-AC-DCU-60-110-E ³ (ID 459273)	
	AXE80Z			AX-AC-DCU-80-120 (ID 207896)		AX-AC-DCU-80-160 (ID 167332)
	AXE100Z			AX-AC-DCU-80-120 (ID 207896)		AX-AC-DCU-80-160 (ID 167332)
	AXE110Z	AX-AC-DCU-110-60 ¹ (ID 281274)			AX-AC-DCU-110-110 (ID 207936)	
	AXE160Z ²	AX-AC-DCU-160-60 (ID 382288)	AX-AC-DCU-160-80 (ID 288848)		AX-AC-DCU-160-110 (ID 357642)	AX-AC-DCU-160-160 (ID 308879)

¹ Distance plate $t = 12 \text{ mm}$

² Distance plate $t = 15 \text{ mm}$

³ Distance plate $t = 6 \text{ mm}$

6.1.4. Cross connections

Cross connections (Figure 6.6) are connecting elements for the mounting of two – axis systems in which the tabletops of the respective axis are mounted on top of each other. The cross connections include all connecting elements required including screws.

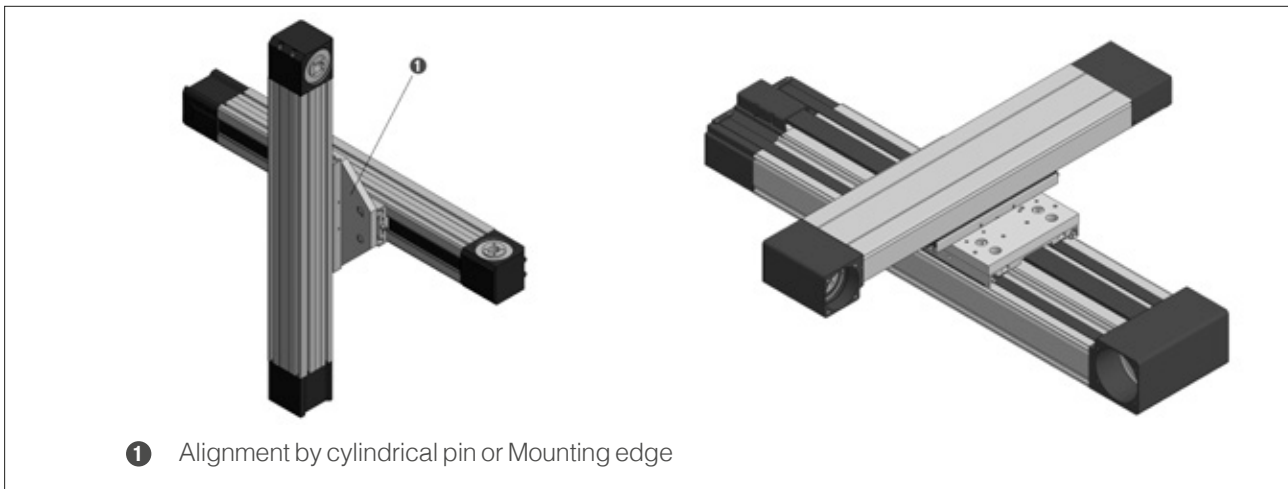

Figure 6.6 Cross connections AXE

The type codes and dimensions including ID numbers of the cross connections are specified in Figure 6.7 and Table 6.4.

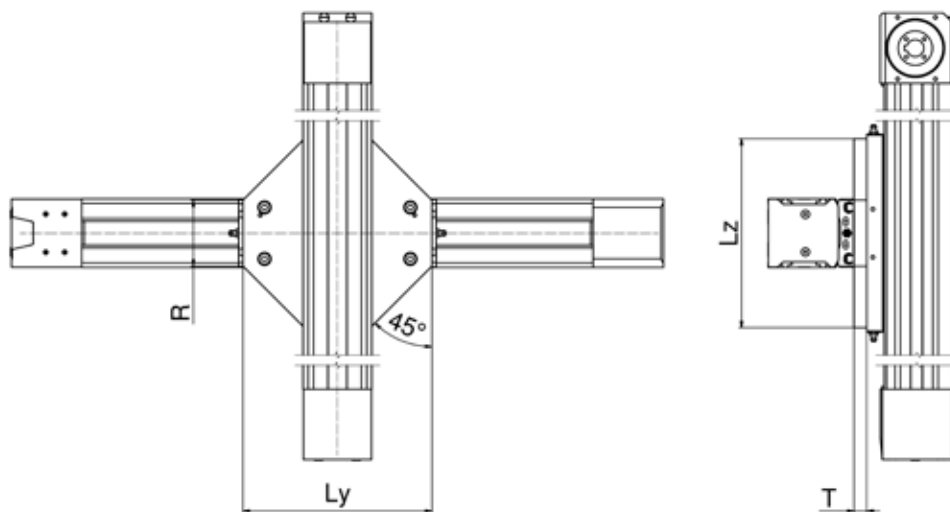

Figure 6.7 Cross connections AXE

- ① Centerline of the Axis = middle slider plate
- ② Note the installation side of the switches for the y – axis in type AXE60

Table 6.4 Cross connections AXE

X - Axis	Y - Axis	Type code	ID number	Ly	Lz [mm]	R [mm]	T [mm]
AXE60Z	AXE60Z	AX-AC-CCU-60-60	160635	90	90	58	12
AXE80Z	AXE60Z	AX-AC-CCU-80-60	158840	190	180	47	11
	AXE100Z	AX-AC-CCU-80-80	253556	220	220	77	15
AXE110Z	AXE60Z	AX-AC-CCU-110-60	252539	215	120		12
AXE160Z	AXE60Z	AX-AC-CCU-160-60	265455	240	160		15
	AXE110Z	AX-AC-CCU-160-80	169160	220	200		20
AXE160Z	AXE110Z	AX-AC-CCU-110-110	259405	215	120		12
AXE110Z	AXE110Z	AX-AC-CCU-160-110	351593	240	160		15
	AXE160Z	AX-AC-CCU-160-160	264974	240	160		15

6.1.5. Gantry connections

Gantry connections (Figure 6.8) are connecting elements for the mounting of x–y-axis systems of linear axes from the AXE series where the Y – axis will be assembled in a position tilted by 90°.

Gantry connections contain all essential connecting elements including screws.

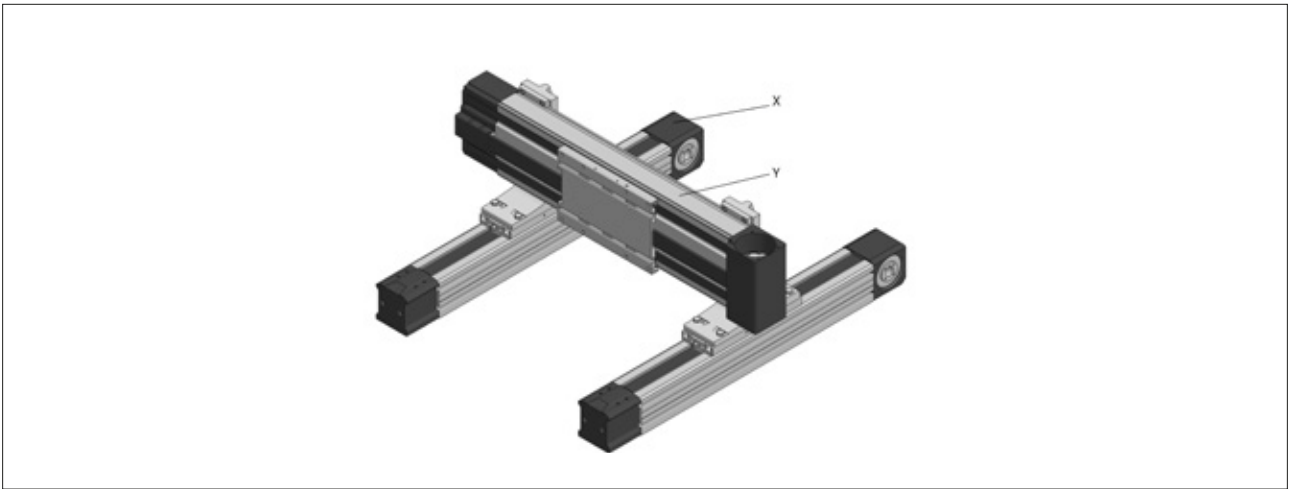

Figure 6.8 Gantry connections AXE

The type codes and dimensions including ID numbers of the gantry connections are specified in Figure 6.9 and Table 6.5.

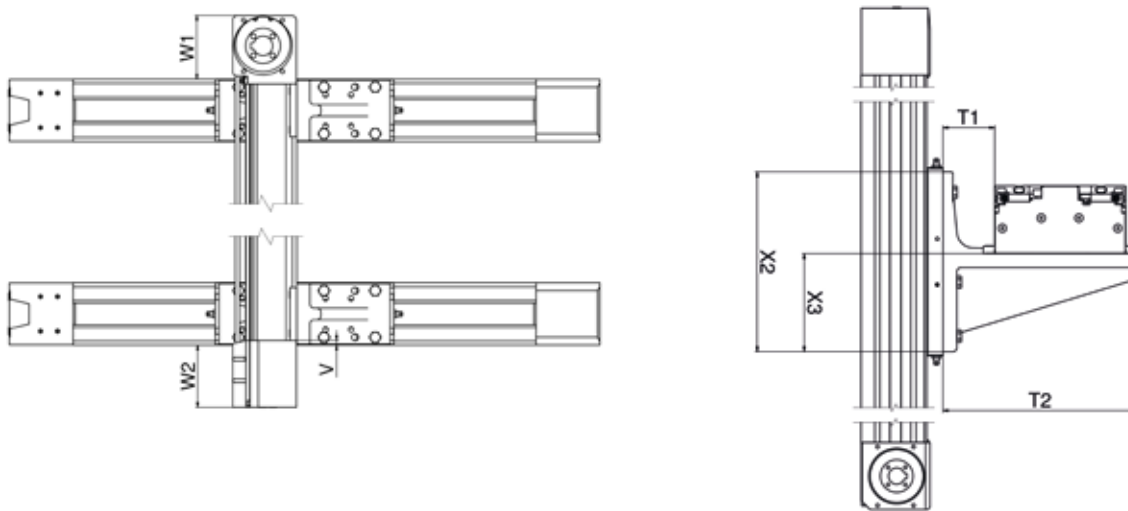

Figure 6.9 Gantry connections AXE

Table 6.5 Gantry connections AXE

X - Axis	Y - Axis	Type code	ID number	T1	T2	V	W1	W2	X2	X3	Y3
					[mm]						
AXE60Z	AXE110Z	AX-AC-GCU-60-110	230361	49	174	5.5	62.5	64.5	160	90	58
	AXE160Z	AX-AC-GCU-60-160	265454	63	237	5.0	92.0	90.0	220	120	78
AXE80Z	AXE160Z	AX-AC-GCU-80-160	169154	63	237	5.0	82.0	80.0	220	120	78
AXE100Z	AXE160Z	AX-AC-GCU-80-160	169154	63	237	5.0	72.0	70.0	220	120	78

6.1.6. A – Standard connections

A - standard connections are connecting elements for the combination of linear axes from the series AXE_Z with toothed belt drive with linear axes from the series AXE_A with axis with toothed belt / 0 – drive (Figure 6.10). The A – standard connections contain all essential connecting elements including screws

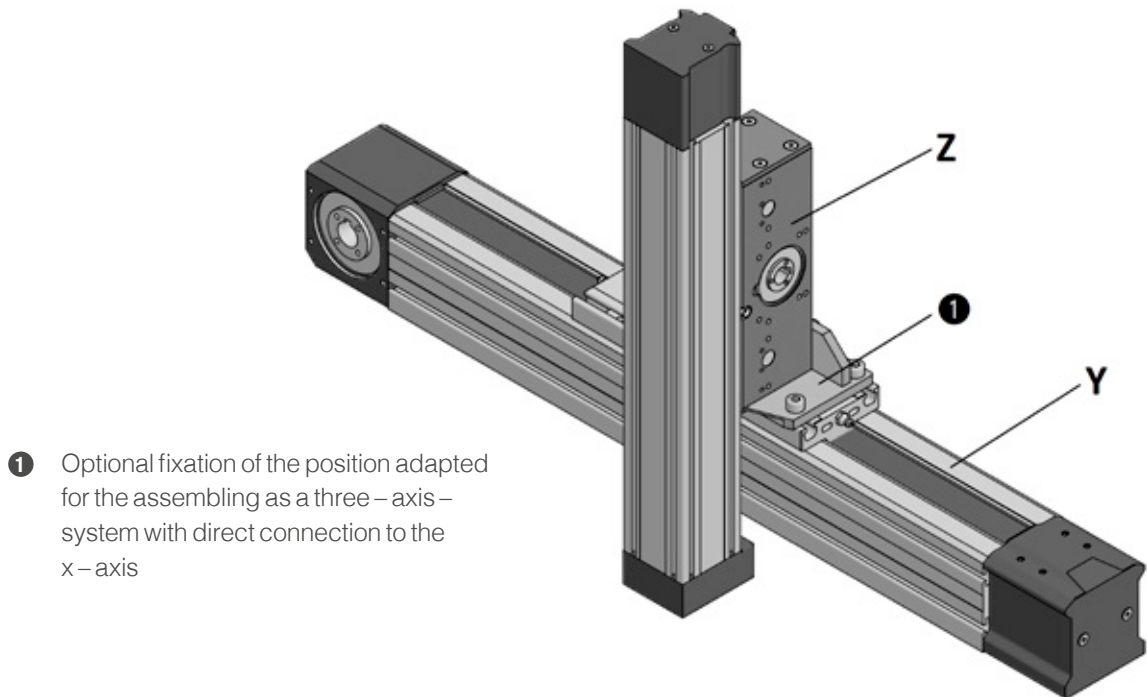

Figure 6.10 A – Standard connections AXE

The type codes and dimensions including ID numbers of the A - standard connections are specified in Figure 6.11 and Table 6.6.

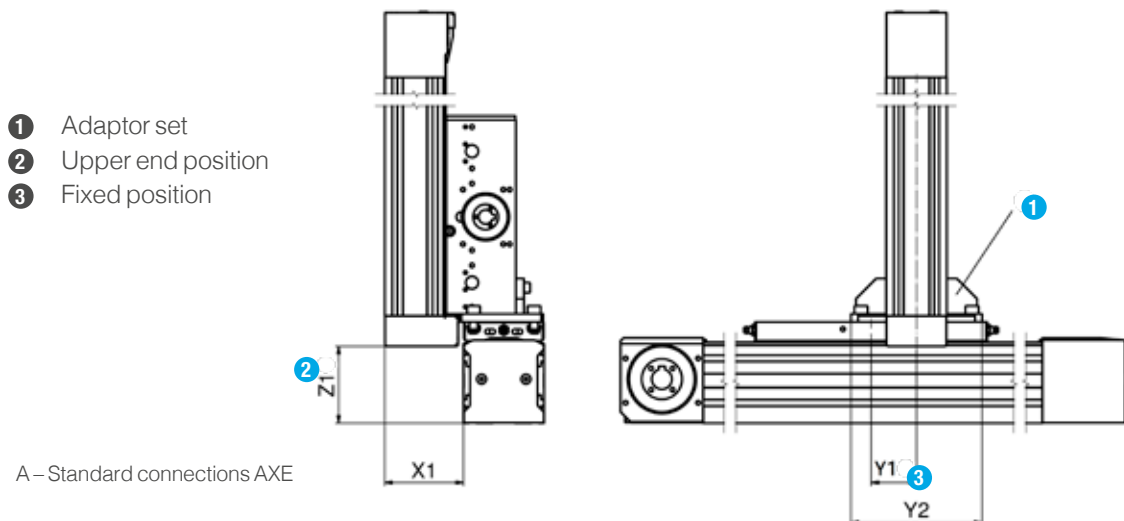

Figure 6.11 A – Standard connections AXE

Table 6.6 A – Standard connections AXE

Y - Axis	Z - Axis	Type code	ID - Number	X1	Y1	Y2	Z1
				[mm]	[mm]	[mm]	[mm]
AXE60Z	AXE40A	AX-AC-SCU-60-40	299881	61	0	120	60
AXE80Z	AXE60A	AX-AC-SCU-80-60	156300	78	45	130	64
AXE110Z	AXE40A	AX-AC-SCU-110-40	327403	61	0	132	43
	AXE60A	AX-AC-SCU-110-60	268606	90	0/18	130	29
AXE160Z	AXE60A	AX-AC-SCU-160-60	458059	75	0	150	51

6.1.7. Angle connections

Angle connections provide a variety of possibilities for the combination of the linear axes AXE110Z and AXE160Z to two-axis systems in x-y or y-z arrangements (Figure 6.12 up to 6.15). Combinations of linear axes of the same size and with a difference of one frame size are possible. The connecting elements are made from aluminum sand casting (EN AC-AISi7Mg0,3 ST6). The angle connections contain all essential connecting elements including screws.

The type codes and dimensions including ID numbers of the angle connections are specified in Figure 6.12 to Figure 6.15 and Table 6.7 to Table 10.

X-Y - axis system, profile assembly

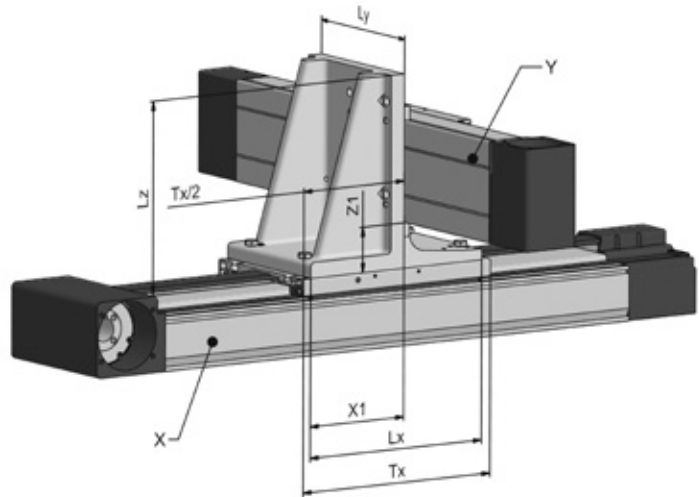

Figure 6.12

Angle connections x-y - Axis system, profile assembly

Table 6.7 Angle connections x-y - Axis system, profile assembly

X - Axis	Y - Axis	Type code	ID number	Lx	X1	Ly	Z1	Lz
				[mm]	[mm]	[mm]	[mm]	[mm]
AXE110	AXE110	AX-AC-ACU-X110-Y110	459876	160	90	156	49.0	209
AXE160	AXE110	AX-AC-ACU-X160-Y110P	286227	160	90	156	49.0	209
AXE160	AXE160	AX-AC-ACU-X160-Y160	306559	220	120	236	63.0	287

X-Y - axis system, tabletop assembly

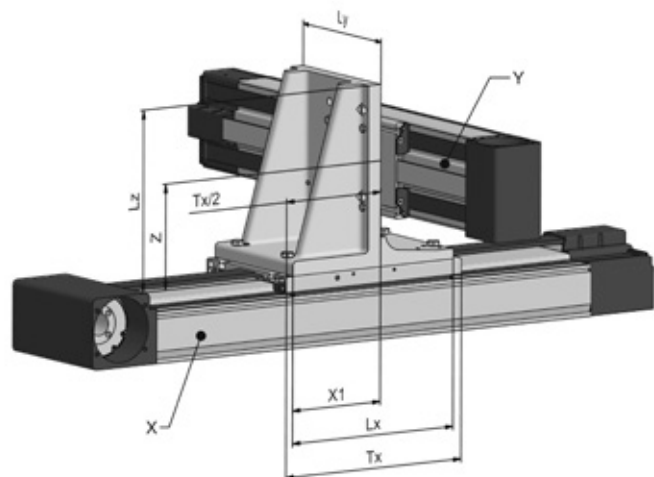

Figure 6.13

Angle connections x-y - Axis system, tabletop assembly

Table 6.8 Angle connections x-y - Axis system, tabletop assembly

X - Axis	Y - Axis	Type code	ID number	Lx	X1	Ly	Z	Lz
				[mm]	[mm]	[mm]	[mm]	[mm]
AXE110	AXE110	AX-AC-ACU-110-110	382293	160	90	156	114.0	209
AXE160	AXE110	AX-AC-ACU-X160-Y110T	382295	160	90	156	114.0	209
AXE160	AXE160	AX-AC-ACU-160-160-2	306666	220	120	236	144.0	287

Y-Z - axis system, profile assembly

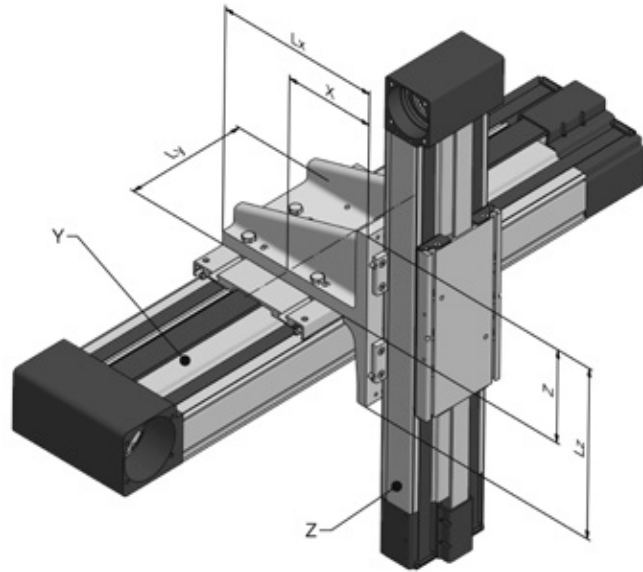

Figure 6.14

Angle connections y-z-axis system, profile assembly

Table 6.9 Angle connections y-z-axis system, profile assembly

X - Axis	Y - Axis	Type code	ID number	Lx	X	Ly	Lz	Z
				[mm]	[mm]	[mm]	[mm]	[mm]
AXE110	AXE110	AX-AC-ACU-Y110-Z110	363425	209	114.0	156	160	90
AXE160	AXE110	AX-AC-ACU-Y160-Z110P	269049	209	130.0	156	160	90
AXE160	AXE160	AX-AC-ACU-Y160-Z160	373108	287	144.0	236	220	120

Y-Z - axis system, tabletop assembly

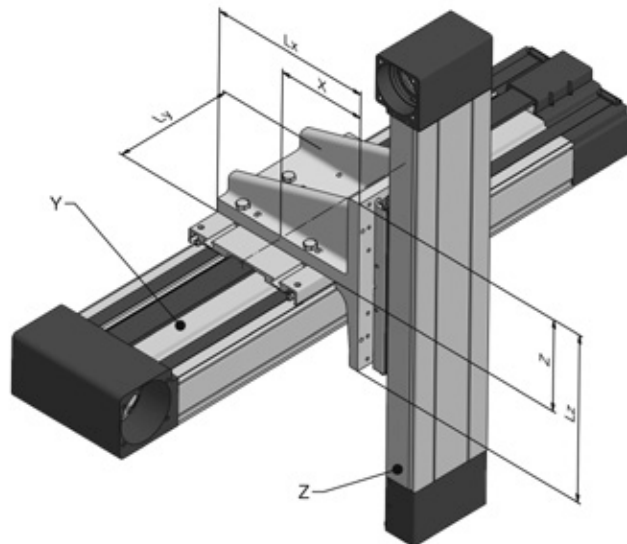

Figure 6.15

Angle connections y-z-Axis system, tabletop assembly

Table 6.10 Angle connections y-z-Axis system, tabletop assembly

X - Axis	Y - Axis	Type code	ID number	Lx	X	Ly	Lz	Z
				[mm]	[mm]	[mm]	[mm]	[mm]
AXE110	AXE110	AX-AC-ACU-110-110	382293	209	114.0	156	160	90
AXE160	AXE110	AX-AC-ACU-Y160-Z110T	267710	209	130.0	156	160	90
AXE160	AXE160	AX-AC-ACU-160-160-2	306666	287	144.0	236	220	120

6.2 Drive options

6.2.1. Plug-in shafts

Plug-in shafts are a common variant of the form-fitting drive adaption (Figure 6.16) available for linear axes from the AXE series. The dimensions are specified in Figure 6.17 and Table 6.11. For applications with higher dynamics, we recommend force and form-fitting drive adaptations with integrated couplings as described in chapter 6.2.2 or 6.2.4.

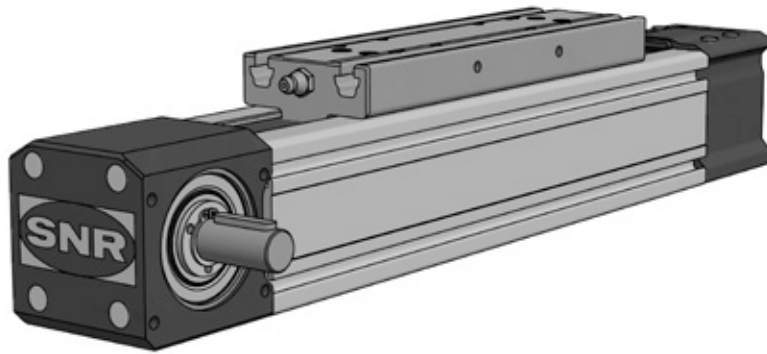

Figure 6.16 Plug-in shaft

The dimensions of the plug-in shafts are specified in Figure 6.17 and Table 6.11.

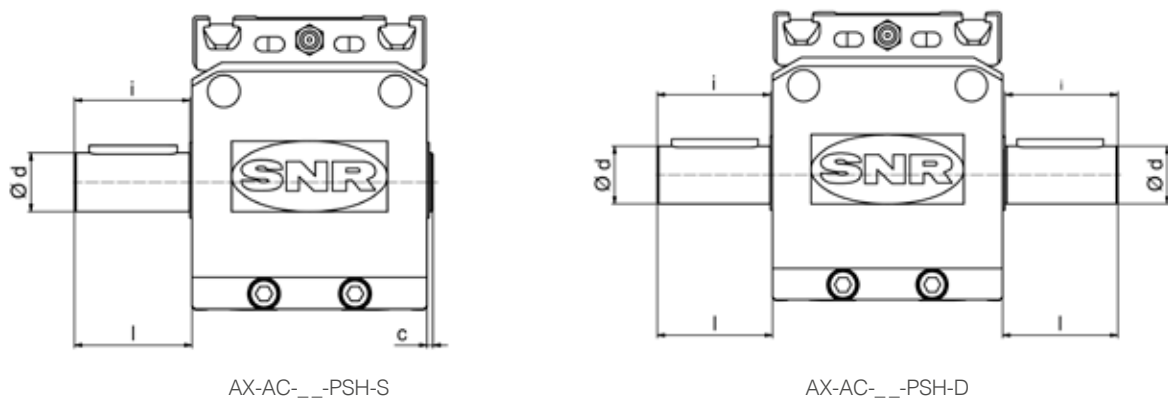

Figure 6.17 Dimensions and mounting dimensions of plug-in shafts

Table 6.11 Dimensions of plug-in shafts

Type	Type code	ID number	c	d h6	i	l
			[mm]	[mm]	[mm]	[mm]
AXE40A	AX-AC-40ZA-PSH-S	156270	1	10	29.5	30
AXE60Z AXE60A	AX-AC-60ZA-PSH-S	187407	1	14	30.0	30
AXE80Z	AX-AC-80ZA-PSH-S	152373	2	20	39.3	40
AXE100Z	AX-AC-100Z-PSH-S	409634		25	53.5	50
AXE110Z	AX-AC-110Z-PSH-S	308746		16	55.5	30
AXE160Z	AX-AC-160Z-PSH-S	206005		25	92.3	50
AXE40A	AX-AC-40ZA-PSH-D	449876		10	29.5	30
AXE60Z AXE60A	AX-AC-60ZA-PSH-D	189202		14	30.0	30
AXE80Z	AX-AC-80ZA-PSH-D	153960		20	39.3	40
AXE100Z	AX-AC-100Z-PSH-D	409633		25	53.5	50

6.2.2. Couplings and connecting shafts

Parallel-arranged linear axes can be linked via a connecting shaft (Figure 6.18). The required drive torque is evenly distributed across all axes. Galvanized hollow shafts are used as connecting shafts. In addition, the linear axes from the AXE series allow subsequent assembly and dismantling using half-shell clamping hubs thereby facilitating precise adjustment of the linear axes.

A complete axis connection consists of a coupling kit (Table 6.12) and the connecting shaft (Table 6.13 to 6.15). For the adaptation of drives, couplings with clamping hub for drives with feather key shafts are available.

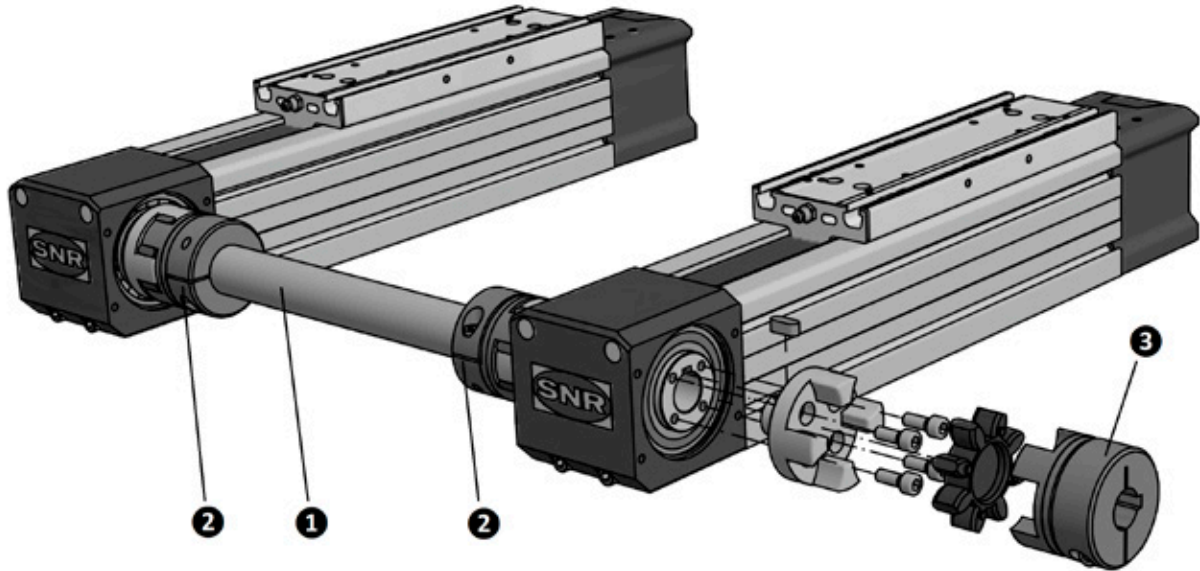

Figure 6.18 Arrangement couplings and connecting shaft

- ① Connecting shaft
- ② Coupling with half-shell clamping hub
- ③ Coupling with clamping hub for drives with feather key shaft

The dimensions of the connecting shafts are specified in Figure 6.19 and Table 6.12.

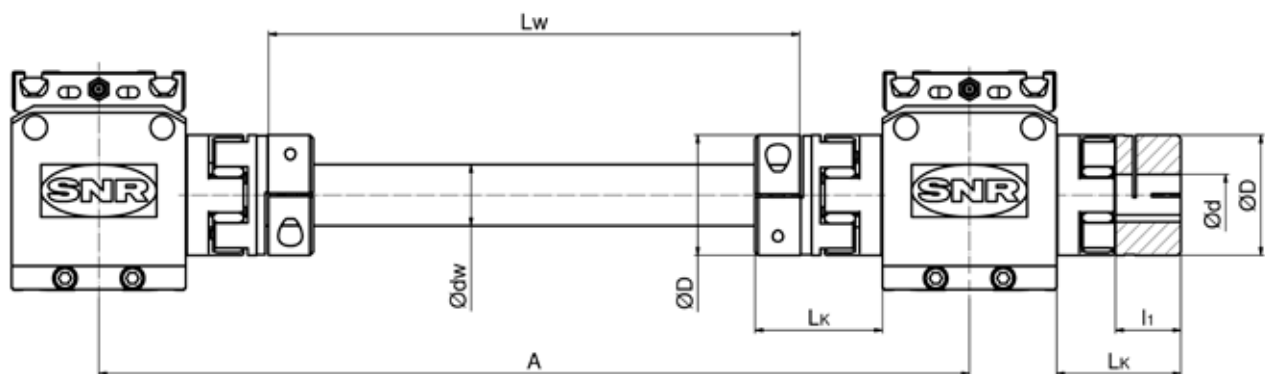

Figure 6.19 Dimension of couplings and connecting shaft

Table 6.12 Dimension of couplings and connecting shaft

Type	Type code	ID number	D	LK	I ¹	d	TA ²	Type code	ID number	Connecting shaft				
	Clamping hub coupling							Coupling kit		dw	(wall thickness)	Lw	A _{min.} ¹	TA ²
			[mm]	[mm]	[mm]	[Nm]			[mm]	[mm]	[mm]	[mm]	[Nm]	
AXE60Z	AX-AC-60ZA-COU-K-10	233232	40	50.0	25.0	10	10.0	AX-AC-60Z-COU-CHS-22	292876	22	2.0	A-125	160	6.0
	AX-AC-60ZA-COU-K-14	188209				14								
	AX-AC-60ZA-COU-K-16	230511				16								
	AX-AC-60ZA-COU-K-19	188958				19								
	AX-AC-60ZA-COU-K-20	185644				20								
AXE80Z	AX-AC-80ZA-COU-K-12	257591	55	59.0	30.0	12	10.0	AX-AC-80Z-COU-CHS-28	153844	28	2.5	A-153	198	10.0
	AX-AC-80ZA-COU-K-14	251343				14								
	AX-AC-80ZA-COU-K-16	187181				16								
	AX-AC-80ZA-COU-K-18	171476				18								
	AX-AC-80ZA-COU-K-19	251662				19								
	AX-AC-80ZA-COU-K-20	151341				20								
	AX-AC-80ZA-COU-K-22	247474				22								
	AX-AC-80ZA-COU-K-25	184826				25								
AXE100Z	AX-AC-100Z-COU-K-38	284121	65	61.0	35.0	38	25.0	AX-AC-100Z-COU-CHS-38	284121	38	4.0	A-172	222	25.0
AXE110Z	AX-AC-110Z-COU-K-12	409353	55	32.5	30.0	12	10.0	not applicable						
	AX-AC-110Z-COU-K-20	409354				20								
	AX-AC-110Z-COU-K-22	409355				22								
	AX-AC-110Z-COU-K-25	sur demande				25								
AXE160Z	AX-AC-160Z-COU-K-20	251324	65	61.0	35.0	20	25.0	not applicable						
	AX-AC-160Z-COU-K-22	238803				22								
	AX-AC-160Z-COU-K-25	304052				25								
	AX-AC-160Z-COU-K-30	203284				30								
	AX-AC-160Z-COU-K-20	251324	65	22.5	35.0	20	AX-AC-160Z-COU-CHS-38	284121	38	4.0	A-172	222	25.0	
	AX-AC-160Z-COU-K-22	238803				22								
	AX-AC-160Z-COU-K-25	304052				25								
	AX-AC-160Z-COU-K-30	203284				30								

¹ Minimum dimension, which allows the removal assembly without disassembly of the linear axis

² Tightening torque

Example type code of connecting shafts:

AX - AC - CHS - 22 - 1000 - 0



For AXE standard axes systems, the corresponding connection shafts including the ID numbers are summarized in Tables 6.13 and 6.14 as well as for the connection of linear axis AXE100 in Table 6.15.

Table 6.14 Connecting shafts for AXE60

Stroke of the Y - Axis (AXE110Z)	Type code	ID number	Center distance A of the X - Axis	Shaft length L	Mass
[mm]			[mm]	[mm]	[kg]
200	AX-AC-CHS-22-0245-0	461314	370	245	0.24
260	AX-AC-CHS-22-0305-0	461313	430	305	0.30
320	AX-AC-CHS-22-0365-0	461312	490	365	0.36
380	AX-AC-CHS-22-0425-0	461311	550	425	0.42
440	AX-AC-CHS-22-0485-0	461310	610	485	0.48
500	AX-AC-CHS-22-0545-0	461309	670	545	0.54
560	AX-AC-CHS-22-0605-0	461307	730	605	0.60
620	AX-AC-CHS-22-0665-0	461306	790	665	0.66
680	AX-AC-CHS-22-0725-0	461305	850	725	0.71
740	AX-AC-CHS-22-0785-0	461304	910	785	0.77
800	AX-AC-CHS-22-0845-0	461303	970	845	0.83
860	AX-AC-CHS-22-0905-0	461302	1030	905	0.89
920	AX-AC-CHS-22-0965-0	461301	1090	965	0.95
980	AX-AC-CHS-22-1025-0	381828	1150	1025	1.01
1040	AX-AC-CHS-22-1085-0	461300	1210	1085	1.07
1100	AX-AC-CHS-22-1145-0	461299	1270	1145	1.13
1160	AX-AC-CHS-22-1205-0	461176	1330	1205	1.19
1220	AX-AC-CHS-22-1265-0	461175	1390	1265	1.25
1280	AX-AC-CHS-22-1325-0	461174	1450	1325	1.31
1340	AX-AC-CHS-22-1385-0	461173	1510	1385	1.37
1400	AX-AC-CHS-22-1445-0	461172	1570	1445	1.42
1460	AX-AC-CHS-22-1505-0	461171	1630	1505	1.48
1520	AX-AC-CHS-22-1565-0	461170	1690	1565	1.54
1580	AX-AC-CHS-22-1625-0	461169	1750	1625	1.60
1640	AX-AC-CHS-22-1685-0	461168	1810	1685	1.66
1700	AX-AC-CHS-22-1745-0	461167	1870	1745	1.72
1820	AX-AC-CHS-22-1865-0	461166	1990	1865	1.84
1940	AX-AC-CHS-22-1985-0	461165	2110	1985	1.96
2060	AX-AC-CHS-22-2105-0	461164	2230	2105	2.08
2180	AX-AC-CHS-22-2225-0	461163	2350	2225	2.19
2300	AX-AC-CHS-22-2345-0	461162	2470	2345	2.31
2420	AX-AC-CHS-22-2465-0	461006	2590	2465	2.43
2540	AX-AC-CHS-22-2585-0	461005	2710	2585	2.55
2660	AX-AC-CHS-22-2705-0	461004	2830	2705	2.67
2780	AX-AC-CHS-22-2825-0	461003	2950	2825	2.79
3020	AX-AC-CHS-22-3065-0	461002	3190	3065	3.02
3260	AX-AC-CHS-22-3305-0	461000	3430	3305	3.26
3500	AX-AC-CHS-22-3545-0	460999	3670	3545	3.50
3740	AX-AC-CHS-22-3785-0	460997	3910	3785	3.73

Table 6.14 Connecting shafts for AXE80

Stroke of the Y - Axis (AXE160Z)	Type code	ID number	Center distance A of the X - Axis	Shaft length L	Mass
[mm]			[mm]	[mm]	[kg]
300	AX-AC-CHS-28-0337-0	460996	490	337	0.53
360	AX-AC-CHS-28-0397-0	460995	550	397	0.62
420	AX-AC-CHS-28-0457-0	460994	610	457	0.72
480	AX-AC-CHS-28-0517-0	460992	670	517	0.81
540	AX-AC-CHS-28-0577-0	460991	730	577	0.91
600	AX-AC-CHS-28-0637-0	460990	790	637	1.00
660	AX-AC-CHS-28-0697-0	460989	850	697	1.10
720	AX-AC-CHS-28-0757-0	460987	910	757	1.19
780	AX-AC-CHS-28-0817-0	460986	970	817	1.28
840	AX-AC-CHS-28-0877-0	460985	1030	877	1.38
900	AX-AC-CHS-28-0937-0	460984	1090	937	1.47
960	AX-AC-CHS-28-0997-0	460983	1150	997	1.57
1020	AX-AC-CHS-28-1057-0	460982	1210	1057	1.66
1080	AX-AC-CHS-28-1117-0	460981	1270	1117	1.76
1140	AX-AC-CHS-28-1177-0	460980	1330	1177	1.85
1200	AX-AC-CHS-28-1237-0	460979	1390	1237	1.94
1260	AX-AC-CHS-28-1297-0	460874	1450	1297	2.04
1320	AX-AC-CHS-28-1357-0	460873	1510	1357	2.13
1380	AX-AC-CHS-28-1417-0	460872	1570	1417	2.23
1440	AX-AC-CHS-28-1477-0	460871	1630	1477	2.32
1500	AX-AC-CHS-28-1537-0	460870	1690	1537	2.42
1560	AX-AC-CHS-28-1597-0	460869	1750	1597	2.51
1620	AX-AC-CHS-28-1657-0	460868	1810	1657	2.60
1680	AX-AC-CHS-28-1717-0	460867	1870	1717	2.70
1800	AX-AC-CHS-28-1837-0	460866	1990	1837	2.89
1920	AX-AC-CHS-28-1957-0	460865	2110	1957	3.08
2040	AX-AC-CHS-28-2077-0	460862	2230	2077	3.27
2160	AX-AC-CHS-28-2197-0	460555	2350	2197	3.45
2280	AX-AC-CHS-28-2317-0	460554	2470	2317	3.64
2400	AX-AC-CHS-28-2437-0	460553	2590	2437	3.83
2520	AX-AC-CHS-28-2557-0	460467	2710	2557	4.02
2640	AX-AC-CHS-28-2677-0	460551	2830	2677	4.21
2760	AX-AC-CHS-28-2797-0	460550	2950	2797	4.40
3000	AX-AC-CHS-28-3037-0	460549	3190	3037	4.77
3240	AX-AC-CHS-28-3277-0	460548	3430	3277	5.15
3480	AX-AC-CHS-28-3517-0	460466	3670	3517	5.53
3720	AX-AC-CHS-28-3757-0	460546	3910	3757	5.91
3960	AX-AC-CHS-28-3997-0	460545	4150	3997	6.28
4200	AX-AC-CHS-28-4237-0	460543	4390	4237	6.66
4500	AX-AC-CHS-28-4537-0	460542	4690	4537	7.13
4800	AX-AC-CHS-28-4837-0	460465	4990	4837	7.60
5100	AX-AC-CHS-28-5137-0	460541	5290	5137	8.08
5400	AX-AC-CHS-28-5437-0	460540	5590	5437	8.55
5700	AX-AC-CHS-28-5737-0	460539	5890	5737	9.02

Table 6.15 Connecting shafts for AXE100

Type code	ID number	Center distance A of the X-Axis	Shaft length L	Mass
		[mm]	[mm]	[kg]
AX-AC-CHS-38-0128-0	460538	300	128	0.43
AX-AC-CHS-38-0188-0	460464	360	188	0.63
AX-AC-CHS-38-0248-0	460537	420	248	0.83
AX-AC-CHS-38-0308-0	460536	480	308	1.03
AX-AC-CHS-38-0368-0	460482	540	368	1.23
AX-AC-CHS-38-0428-0	460480	600	428	1.43
AX-AC-CHS-38-0488-0	460463	660	488	1.63
AX-AC-CHS-38-0548-0	460479	720	548	1.84
AX-AC-CHS-38-0608-0	460478	780	608	2.04
AX-AC-CHS-38-0668-0	460477	840	668	2.24
AX-AC-CHS-38-0728-0	460476	900	728	2.44
AX-AC-CHS-38-0788-0	460462	960	788	2.64
AX-AC-CHS-38-0848-0	460475	1020	848	2.84
AX-AC-CHS-38-0908-0	460474	1080	908	3.04
AX-AC-CHS-38-968-0	460473	1140	968	3.24
AX-AC-CHS-38-1028-0	460472	1200	1028	3.44
AX-AC-CHS-38-1088-0	460460	1260	1088	3.64
AX-AC-CHS-38-1148-0	460471	1320	1148	3.85
AX-AC-CHS-38-1208-0	460470	1380	1208	4.05
AX-AC-CHS-38-1268-0	460469	1440	1268	4.25
AX-AC-CHS-38-1328-0	460468	1500	1328	4.45
AX-AC-CHS-38-1388-0	460459	1560	1388	4.65
AX-AC-CHS-38-1448-0	460458	1620	1448	4.85
AX-AC-CHS-38-1508-0	460457	1680	1508	5.05
AX-AC-CHS-38-1628-0	460456	1800	1628	5.45
AX-AC-CHS-38-1748-0	460454	1920	1748	5.86
AX-AC-CHS-38-1868-0	460453	2040	1868	6.26
AX-AC-CHS-38-1988-0	460452	2160	1988	6.66
AX-AC-CHS-38-2108-0	460451	2280	2108	7.06
AX-AC-CHS-38-2228-0	460429	2400	2228	7.46
AX-AC-CHS-38-2348-0	460428	2520	2348	7.87
AX-AC-CHS-38-2468-0	460427	2640	2468	8.27
AX-AC-CHS-38-2588-0	460426	2760	2588	8.67
AX-AC-CHS-38-2828-0	460425	3000	2828	9.47
AX-AC-CHS-38-3068-0	460424	3240	3068	10.28
AX-AC-CHS-38-3308-0	460423	3480	3308	11.08
AX-AC-CHS-38-3548-0	460422	3720	3548	11.89
AX-AC-CHS-38-3788-0	460421	3960	3788	12.69
AX-AC-CHS-38-4028-0	460419	4200	4028	13.49
AX-AC-CHS-38-4328-0	460418	4500	4328	14.50
AX-AC-CHS-38-4628-0	460416	4800	4628	15.50
AX-AC-CHS-38-4928-0	460415	5100	4928	16.51
AX-AC-CHS-38-5228-0	460414	5400	5228	17.51
AX-AC-CHS-38-5528-0	460413	5700	5528	18.52

When the connecting shaft is of great length and operating with high velocity, the critical speed must be considered. The diagram in Figure 6.20 shows the maximum speed depending on the center distance of the linear axis. The basis of the limits here are 50% of the critical speed. For higher requirements, please contact our application engineers.

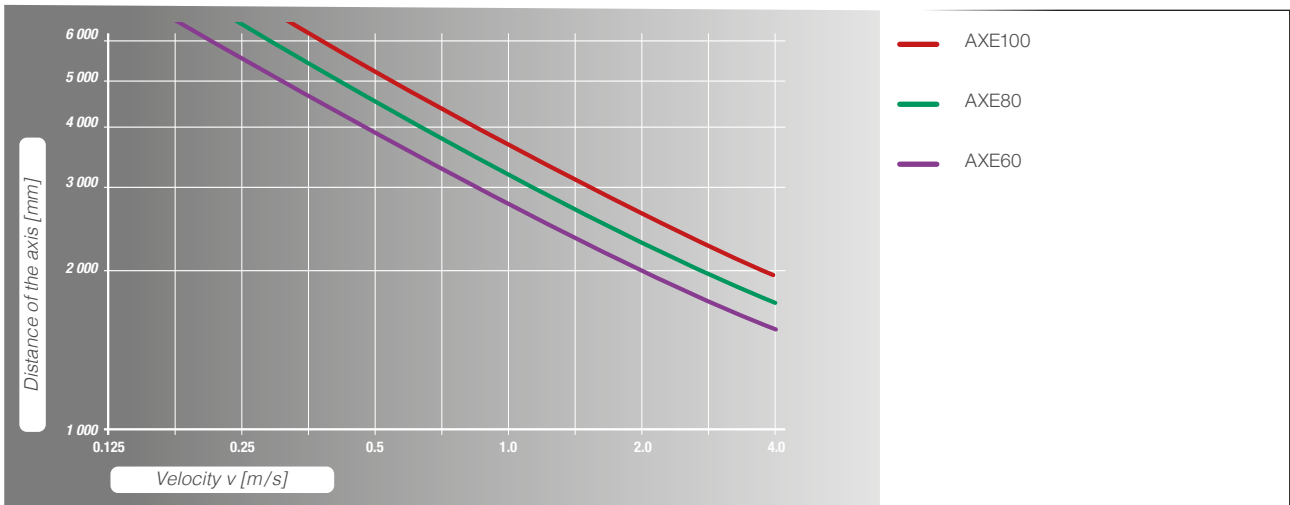

Figure 6.27 Dynamic limits for connecting shafts

6.2.3. Planetary gearboxes / Motor adapter

For linear axes of the AXE series, planetary gearboxes with different ratios are available. Table 6.16 summarizes the technical data for the planetary gearboxes.

Table 6.16 Planetary gearboxes

Type	Gearbox designation	ID Number	Clamping system	Gear ratio i	Maximum acceleration moment	Permissible input speed	Maximum input speed	Backlash	Mass	Mass moment of inertia
					[Nm]'	[min ⁻¹]	[min ⁻¹]			[kgcm ² to d]
AXE40A	AX-AC-PGE040-010-C9	468332	C9	10	13	4 300	9 000	≤ 12	0.50	0.03
AXE60A	AX-AC-PGE060-005-C19	468335	C19	5	40	3 300	7 000	≤ 12	1.40	0.39
AXE60Z AXE110Z	AX-AC-PGE060-010-C14	468334	C14	10	35	4 000				0.15
AXE80	AX-AC-PGE080-005-C19	468336	C19	5	100	3 100	7 000	≤ 12	2.90	0.48
AXE160	AX-AC-PGE080-010-C19	468337		10	90	3 600				0.40
AXE100Z	AX-AC-PGE115-005-C24	468338	C24	5	250	2 300	5 500	≤ 12	7.50	1.70
	AX-AC-PGE115-010-C24	468339		10	220	2 800				1.40

For conventional drives corresponding flanges are available to be mounted on the planetary gearboxes. In Table 6.17 the code numbers and dimensions for the different linear axes are summarized and their dimensions are specified in Figure 6.28.

When selecting, please ensure that the size of the clamping systems of the motor adapter and the planetary gearbox will match.

Table 6.17 Dimension motor adapters

Type code	ID number	Clamping system	D	d	max. shaft length	b	e	F	T	M_
			[mm]	[mm]	[mm]	[mm]	[mm]	[mm]	[mm]	[mm]
AX-AC-MAU-E63-B40-D9x20-M4-C9	468209	C9	60	9	20	40	63	3.3	15.0	M4
AX-AC-MAU-E63-B40-D9x20-M5-C14	468215	C14	60	9	20	40	63	3.4	16.1	M5
AX-AC-MAU-E95-B50-D14x30-M6-C14	468217		80	14	30	50	95	5.3	21.2	M6
AX-AC-MAU-E70-B50-D14x30-M5-C14	468218		80	14	30	50	70	4.0	21.2	M5
AX-AC-MAU-E75-B60-D14x30-M5-C14	468219		70	14	30	60	75	3.3	23.1	M5
AX-AC-MAU-E95-B50-D14x30-M6-C19	468220	C19	80	14	30	50	95	4.0	21.2	M6
AX-AC-MAU-E70-B50-D14x30-M5-C19	468221		80	14	30	50	70	4.4	21.2	M5
AX-AC-MAU-E90-B70-D19x40-M5-C19	468223		80	19	40	70	90	4.4	21.2	M5
AX-AC-MAU-E100-B80-D19x40-M6-C19	468225		80	19	40	80	100	6.4	31.2	M6
AX-AC-MAU-E115-B95-D19x40-M8-C19	468226		80	19	40	95	115	5.3	21.2	M8
AX-AC-MAU-E75-B60-D11x23-M5-C19	468228		90	11	23	60	75	4.4	21.2	M5
AX-AC-MAU-E75-B60-D14x30-M5-C19	468229		90	14	30	60	75	7.4	31.2	M5
AX-AC-MAU-E100-B80-D14x30-M6-C19	468230		100	14	30	80	100	10.5	31.2	M6
AX-AC-MAU-E75-B60-D14x30-M5-C24	468231	C24	115	14	30	60	75	4.4	21.8	M5
AX-AC-MAU-E95-B50-D14x30-M6-C24	468232		115	14	30	50	95	4.4	21.8	M6
AX-AC-MAU-E100-B80-D14x30-M6-C24	468233		115	14	30	80	100	5.4	21.8	M6
AX-AC-MAU-E115-B95-D19x40-M8-C24	468235		115	19	40	95	115	6.0	31.8	M8
AX-AC-MAU-E130-B110-D19x40-M8-C24	468240		115	19	40	110	130	4.4	31.8	M8
AX-AC-MAU-E130-B110-D24x50-M8-C24	468327		115	24	50	110	130	4.4	31.8	M8
AX-AC-MAU-E130-B95-D19x40-M8-C24	468329		115	19	40	95	130	5.4	31.8	M8
AX-AC-MAU-E130-B95-D24x50-M8-C24	468331		115	24	50	95	130	5.4	31.8	M8

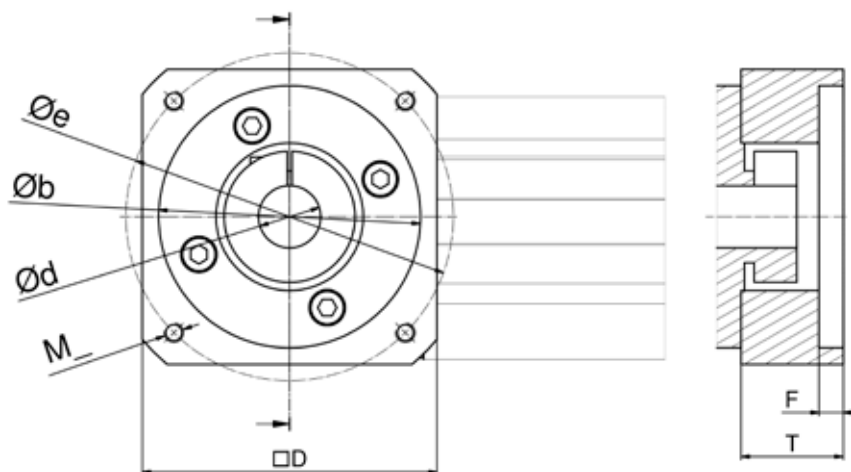

Figure 6.28 Dimensions motor adapter

6.2.3.1 Form-fitted mounting of the planetary gearboxes

Form-fitted mounting of the planetary gearboxes is the simplest version of mounting a gearbox on SNR linear axes with toothed belt drive from the AXE series. Here, the gearbox shaft with feather key is inserted into the hollow shaft of the drive pulley in a form-fitted manner. This version is suitable for applications with low dynamics and low alternating loads, such as for vertical applications. By direct mounting the coupling cone, plug-in shaft and coupling are not required, thus resulting in extremely compact dimensions with a reduction of the moment of inertia and lowering the drive torque values.

Table 6.18 summarizes the dimensions of the available adapters for the different linear axes and Table 6.19 shows the standard planetary gearboxes with their matching adapters. The dimensions are specified in Figure 6.31 and 6.33 (Chapter 6.2.3.2).

Table 6.18 Dimensions of adapters for form-fitted gearbox mounting

Type	Type code	ID Number	Design type	e2	α	s1	b2	d	$i_{2,max.}$	$i_{2,max.-I}$	k2	a2	L2
				[mm]	[°]		[mm]	[mm]	[mm]	[mm]	[mm]	[mm]	[mm]
AXE40A	AX-AC-40ZA-DAD-C	239690	B14 C40	34	45	4 x Ø 4,3	26	10	31	4.0	-	-	3.1
AXE60Z	AX-AC-60ZA-DAD-A	190466	B14 C60	52	45	4 x Ø 5,5	40	14	47	10	60	-	10
AXE60A	AX-AC-60ZA-DAD-C	165758	B5 C120	100	45	4 x M6 x 8	80	14	50	8.0	100	120	8.0
AXE80Z	AX-AC-80ZA-DAD-A	187286	B14 C80	70	45	4 x Ø 6,5	60	20	71	12	82	-	12
	AX-AC-80ZA-DAD-E	168623	B5 C120	100	45	4 x M6 x 12	80	20	72	12.5	-	120	12.5
AXE100Z	AX-AC-100Z-DAE-A	409338	B5 C120	100	45	4 x M6 x 12	80	25	82	17	103	120	12
	AX-AC-100Z-DAE-B	400760	B14 C120	100	45	4 x Ø 6,5	80	25	82	17	100	115	12
	AX-AC-100Z-DAE-C	410937	B5 C160	130	45	4 x M8 x 12	110	25	82	17	115	145	12

Table 6.19 Dimensions of form-fitted mounted planetary gearboxes

Type	Type code	ID Number	Gear ratio i	L	Type code adapter	ID Number
				[mm]		
AXE40A	AX-AC-PGE040-010-C9	468332	10	63.7	AX-AC-40ZF-DAD-C	239690
AXE60A	AX-AC-PGE060-005-C19	468335	5	62.0	AX-AC-60AF-DAD-A	190466
AXE60Z	AX-AC-PGE060-010-C14	468334	10	90.5		
AXE80Z	AX-AC-PGE080-005-C19	468336	5	111.5	AX-AC-80ZF-DAD-A	187286
	AX-AC-PGE080-010-C19	468337	10	111.5		
AXE100Z	AX-AC-PGE115-005-C24	468338	5	143.3	AX-AC-100ZF-DAE-B	400760
	AX-AC-PGE115-010-C24	468339	10	143.3		

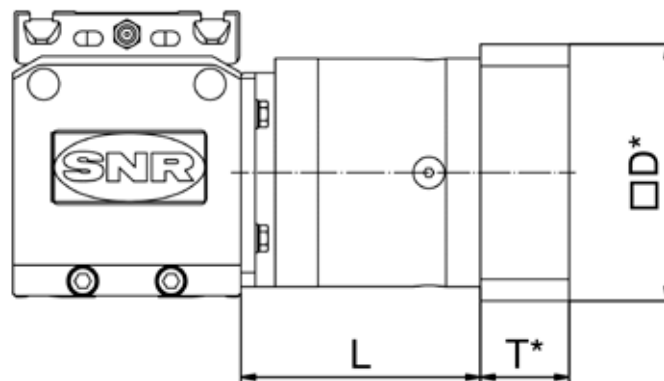

Figure 6.29 Dimension of AXE with form-fitted mounted planetary gearboxes

6.2.3.2 Force-fitted mounting of planetary gearboxes via coupling and coupling cone

A universal version is the adaptation by integrated coupling in combination with a coupling cone. Here, the drive-side coupling half is screwed to the drive pulley and offers optimum reliability through the force-fitted torque transmission even at high dynamics. Grooved clamping hubs are applied as standard for drive shafts with feather key.

For conventional drives with a standard B5 flange a wide range of coupling cones is available. Clamping hubs with grooves are used as standard for driving shafts with feather keys. In Table 6.20 the code numbers and dimensions for the various linear axes are summarized and the dimensions specified in Figure 6.30.

Table 6.20 Code numbers and dimensions for force-fitted mounting of planetary gearboxes via coupling and coupling cone

Type	Type code	ID Number	Design type flange	b2	e2	a	s1	d	L2	LK ¹
				[mm]	[mm]			[mm]		
AXE40A	AX-AC-40ZA-CCO-A-08	186859	B5 TK63	40	63	45	4 x M4 x 8	8	37.0	31.0
	AX-AC-40ZA-CCO-A-09	186857						9		
AXE60Z	AX-AC-60ZA-CCO-A-16	169893	LP070	52	62	0	4 x Ø 5,5	16	58.0	50.0
	AX-AC-60ZA-CCO-E-19	171711						19		
AXE60A	AX-AC-60ZA-CCO-E-20	171712	B5 C120	80	100	45	4 x M6 x 12	20	65.0	50.0
	AX-AC-60ZA-CCO-I-14	187161						14		
AXE80Z	AX-AC-80ZA-CCO-A-19	160928	B14 C60	40	52	45	4 x Ø 5,5	19	56.5	50.0
	AX-AC-80ZA-CCO-A-20	160929						20		
	AX-AC-80ZA-CCO-A-24	160930						24		
	AX-AC-80ZA-CCO-A-25	160931						25		
	AX-AC-80ZA-CCO-B-19	160984	B5 C160	110	130	45	4 x M8 x 16	19	74.0	
	AX-AC-80ZA-CCO-B-20	160987						20		
	AX-AC-80ZA-CCO-B-25	230960						25		
AXE80Z	AX-AC-80ZA-CCO-C-14	244920	B5 C120	80	100	45	4 x M6 x 15	14	62.0	59.0
	AX-AC-80ZA-CCO-C-20	161016						20		
	AX-AC-80ZA-CCO-D-16	161043	LP070	52	62	0	4 x Ø 5,5	16	66.0	
	AX-AC-80ZA-CCO-E-22	161046						22		
AXE100	AX-AC-80ZA-CCO-F-20	161308	B14 C80	60	70	45	4 x Ø 6,5	20	70.0	61.0
	AX-AC-100Z-CCO-A-25	400753	B14 C120	80	100	45	4 x Ø 10,5 x 14	25	76.0	
	AX-AC-100Z-CCO-A-20	400616	B5 C120	80	100	45	4 x M6 x 15	20	65.0	
	AX-AC-100Z-CCO-B-25	409852						25		
	AX-AC-100Z-CCO-B-30	400748	B5 C160	110	130	45	4 x M8 x 20	30	78.0	
AX-AC-100Z-CCO-C-22	400756	LP090	68	80	0	4 x Ø 6,6	22	85.0		
AXE110	AX-AC-110Z-CCO-A-20	308887	B5 C120	80	100	45	4 x M6 x 10	20	42.5	32.5
	AX-AC-110Z-CCO-C-16	164502	LP070	52	62	0	4 x Ø 5,5	16	40.5	
	AX-AC-110Z-CCO-E-14	183464	CP060	40	52	45	4 x Ø 5,5	14	40.5	
AXE160	AX-AC-110Z-CCO-F-20	253672	B14 C80	60	70	45	4 x Ø 6,6	20	54.5	22.5
	AX-AC-160Z-CCO-A-20	154897	B5 C120	80	100	45	4 x M6 x 15	20	22.5	
	AX-AC-160Z-CCO-B-16	163809	LP070	52	62	0	4 x Ø 5,5	16	31.0	
	AX-AC-160Z-CCO-C-22	160340	LP090	68	80	0	4 x Ø 6,6	22	33.5	
	AX-AC-160Z-CCO-D-20	173137	B14 C80	60	70	45	4 x Ø 6,6	20	28.5	
AXE160	AX-AC-160Z-CCO-E-25	185836	B5 C160	110	130	45	4 x M8 x 18	25	39.5	
	AX-AC-160Z-CCO-E-30	185844						30		

¹ Dimension in Chapter 3.8, Figure 3.8

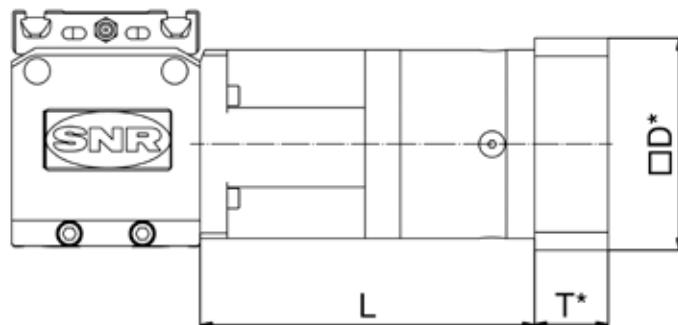

Figure 6.30 Assembly dimensions of force-fitted mounting of planetary gearboxes via coupling and coupling cone

*see Chapter 6.2.3.3

Table 6.21 shows the standard planetary gearboxes with their matching adapters. The dimensions are specified in Figure 6.31 and 6.32.

Table 6.21 Assembly dimensions of force-fitted mounting of planetary gearboxes via coupling and coupling cone

Type	Gearbox designation	ID Number	Clamping system	Gear ratio i	L	Type code adapter	ID Number
					[mm]		
AXE60A AXE60Z	AX-AC-PGE060-005-C19	468335	C14	5	62.0	AX-AC-CCO60-Z- A-G14-I	187161
	AX-AC-PGE060-010-C14	468334	C19	10	90.5		
AXE80Z	AX-AC-PGE080-005-C19	468336	C19	5	111.5	AX-AC-CCO80-Z- A-GS20-F	161308
	AX-AC-PGE080-010-C19	468337		10	111.5		
AXE100Z	AX-AC-PGE115-005-C24	468338	C24	5	143.3	AX-AC-CCO100-Z- G25-A	400753
	AX-AC-PGE115-010-C24	468339		10	143.3		
AXE110Z	AX-AC-PGE060-005-C19	468335	C14	5	62.0	AX-AC-CCO110-Z- MP060	183464
	AX-AC-PGE060-010-C14	468334	C19	10	90.5		
AXE160Z	AX-AC-PGE080-005-C19	468336	C19	5	111.5	AX-AC-CCO160-Z-D	173137
	AX-AC-PGE080-010-C19	468337		10	111.5		

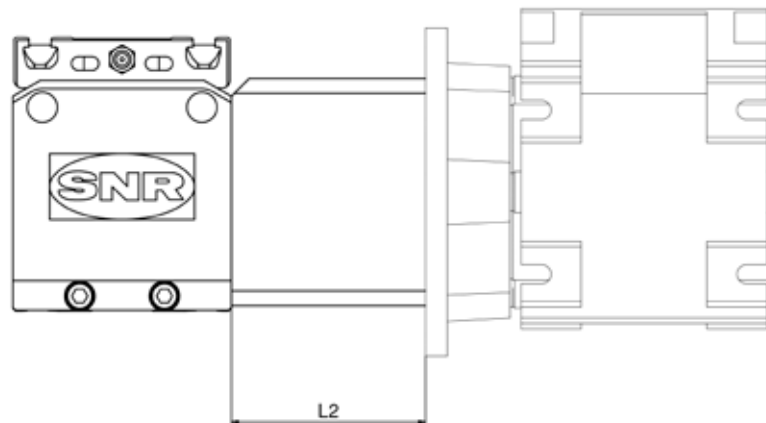

Figure 6.31 Dimension coupling cone

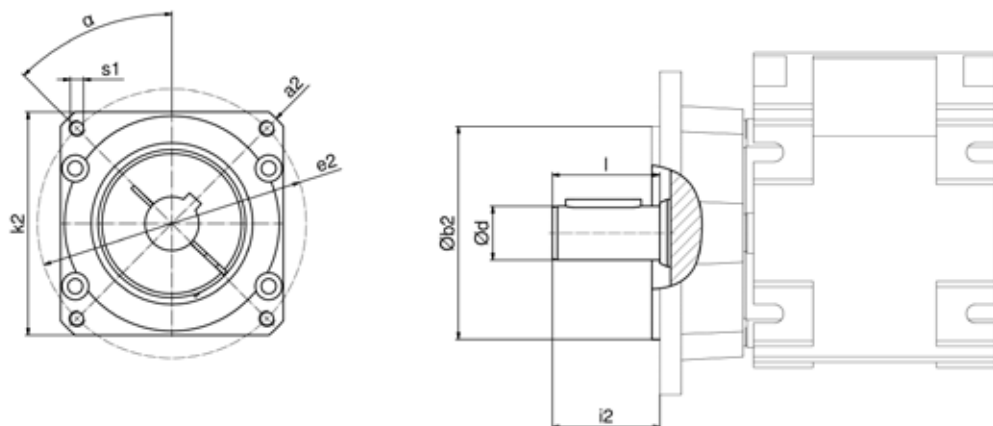

Figure 6.32 Dimension drive adapter

6.3 Limit switches

6.3.1. Limit switch versions

For the various position detection requirements mechanical switches are available of different IP protection classes as well as inductive proximity switches with standard output circuits.

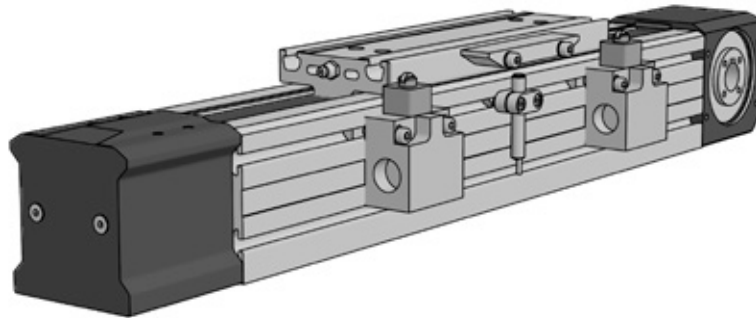

Figure 6.33 Linear axis with a set of mechanical limit switches and inductive proximity switch

For emergency shutdown of the drives before the mechanical end position dampers can be reached, usually mechanically actuated switches are employed. A combination with externally positioned inductive proximity switches is possible in order to provide additional switching points, e.g. for reference movements. A mechanical limit switch set consists of one switch with fastening elements.

An extremely compact version for linear axes from the AXE series is the inductive proximity switches for installation in the profile grooves (Figure 6.34), since they are flush with the surface of the aluminum profile of the axis and create almost no interference contour. In this case, a groove inserts (Chapter 6.5) should also be mounted to ensure correct positioning of the cable inside the groove.

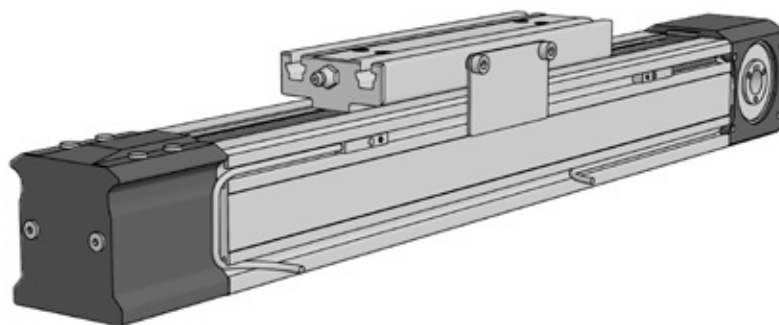

Figure 6.34 Inductive proximity switches for groove installation

The inductive proximity switches are available in the versions PNP-NC (opener), PNP-NO (closer) and NPN-NC (opener). An inductive proximity switches set consists of one switch with fasteners and the actuating element.

6.3.2. Cable guiding

The cables of the inductive proximity switches for the AXE series are laid in a tightening groove guiding to the drive (AXE80 and 100) or deflection pulley (AXE160), respectively.

For type AXE60, only two inductive proximity switches per side can be used for cable guiding to the respective profile ends.

For linear axis AXE110Z, the cable guiding of two proximity switches (at a maximum) is positioned on top of the profile in two grooves (Chapter 3.12.3) to a hole in the deflection head for each proximity switch separately.

6.3.3. Mounting versions

Depending on size and drive type, there is a variety of combination and assembly options of limit switches, which are summarized in Table 6.22. An overview of possible combinations is given in Table 6.26, Chapter 6.3.5.

Table 6.22 Limit switch mounting on SNR linear axes AXE

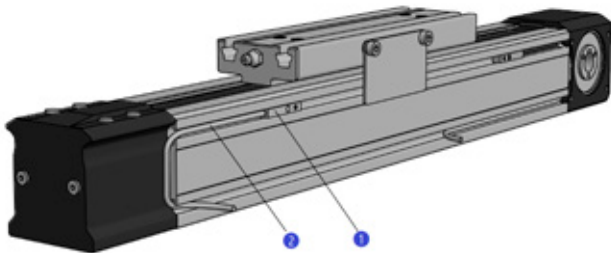
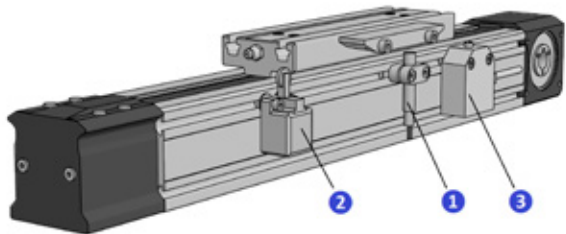
Axe	
AXE60Z	<p>Inductive proximity switches</p>  <p> 1 Inductive proximity switches (groove installation) 2 Cable guiding </p>
	<p>Mechanical (IP30, IP67) and inductive proximity switches</p>  <p> 1 Inductive proximity switches 2 Mechanical limit switch IP30 3 Mechanical limit switch IP67 </p>

Inductive proximity switches

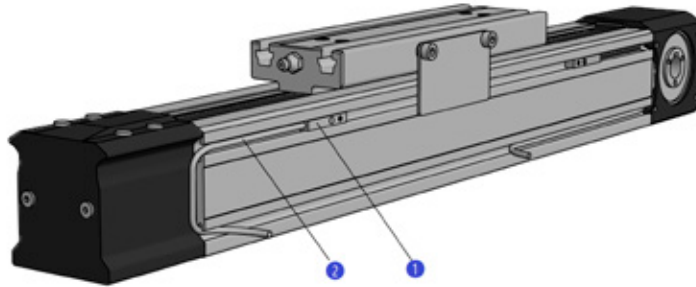

- ① Inductive proximity switches (groove installation)
- ② Cable guiding

AXE80Z
AXE100Z

Mechanical (IP67) and inductive proximity switches

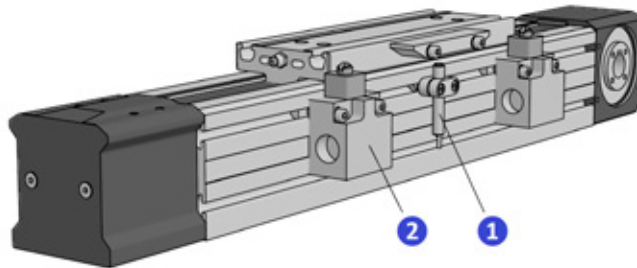

- ① Inductive proximity switches
- ② Mechanical limit switch IP67

Mechanical (IP30) and inductive proximity switches

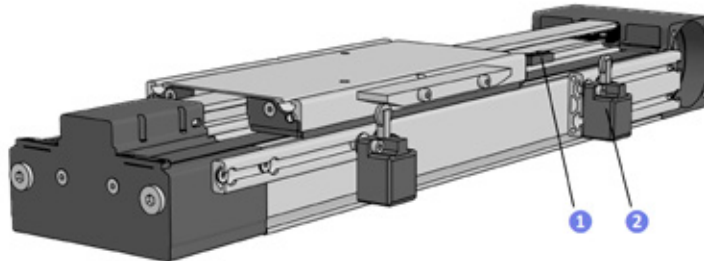

- ① Inductive proximity switches
- ② Mechanical limit switch IP30

AXE110Z

Mechanical (IP67) and inductive proximity switches

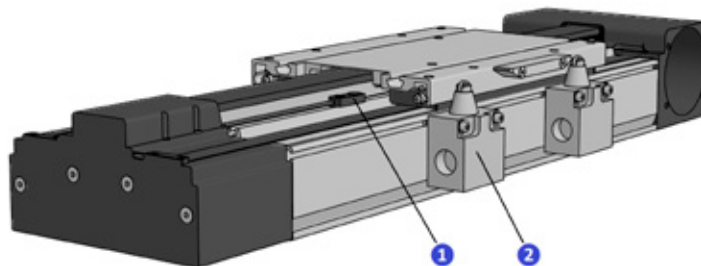

- ① Inductive proximity switches
- ② Mechanical limit switch IP67

AXE160Z

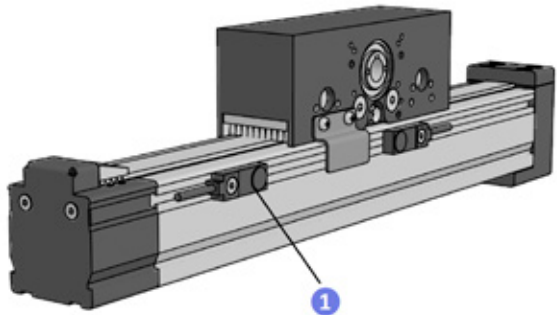
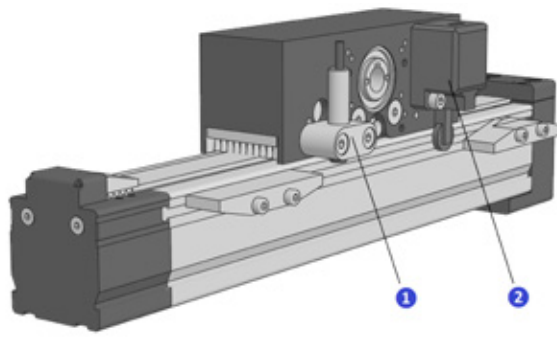
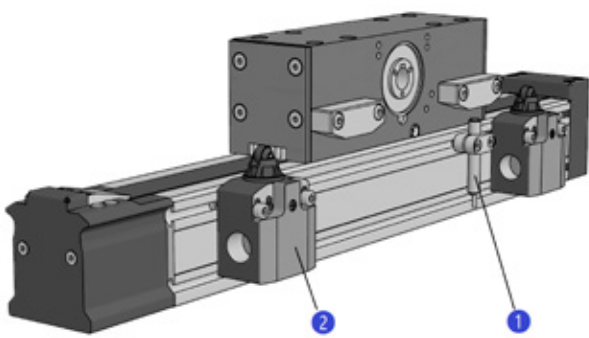
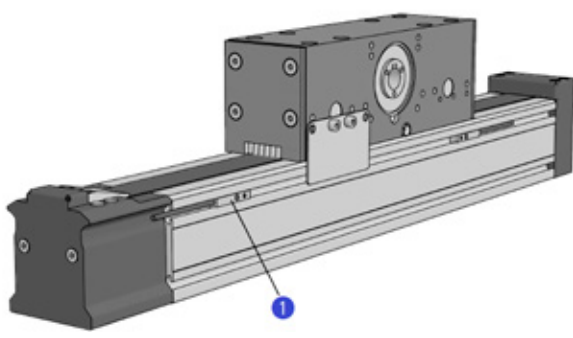
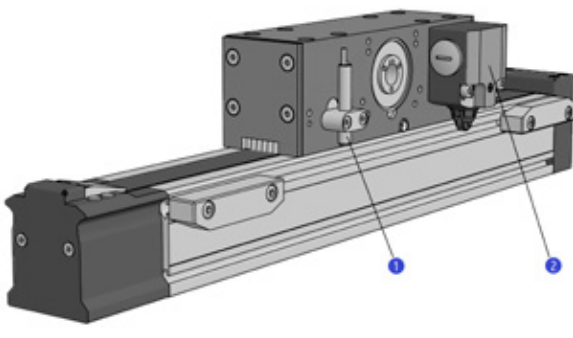
	<p>Slider moved Inductive proximity switches</p>	
<p>AXE40A</p>	<p>Profile moved Mechanical (IP30) and inductive proximity switches</p>	
	<p>Slider moved Mechanical (IP67) and inductive proximity switches</p>	
<p>AXE60A</p>	<p>Slider moved Inductive proximity switches</p>	
	<p>Profile moved Mechanical (IP67) and inductive proximity switches</p>	

Dimensions

For the assembly of limit switches for linear axis from the AXE series there are different size dependent mounting versions (Figure 6.35) and interference contours created hereby.

Mounting version 1

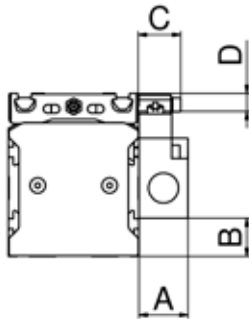

Mounting version 2

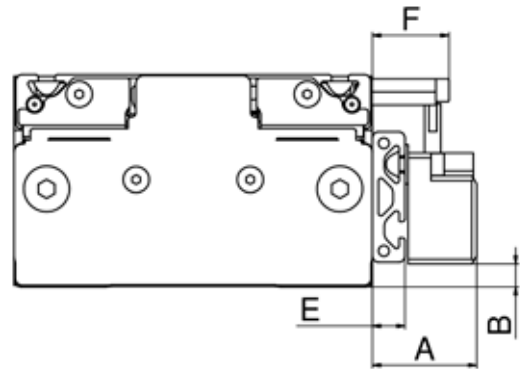

Mounting version 3

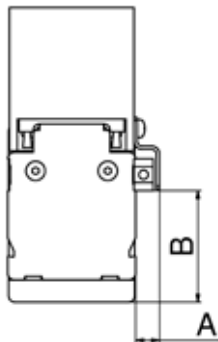

Mounting version 4

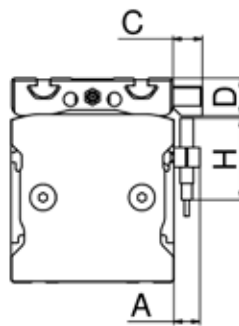

Mounting version 5

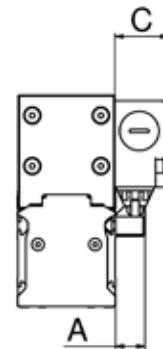

Figure 6.35 Mounting version of limit switches

The dimensions are specified in Table 6.23.

Table 6.23 Dimension limit switch mounting

Type	Switch	Mounting version	A	B	C	D	E	F	G	H	L ¹
			[mm]	[mm]	[mm]	[mm]	[mm]	[mm]	[mm]	[mm]	[mm]
AXE60Z	AX-AC-60-SUN-M2	1	22.0	19.5	25	11.5					95
	AX-AC-60-SUN-M3	1	20.0	12.5	18	19.0					80
	AX-AC-60Z-SUN-I2-...	4	16.0		18	19.0				50	
AXE80Z	AX-AC-80-SUN-M1	1	30.0	25.5	26	11.0					95
	AX-AC-80Z-SUN-I2-...	4	16.0		26	11.0				50	95
AXE100Z	AX-AC-100-SUN-M1	1	30.0	22.5	15	23.5					80
	AX-AC-100Z-SUN-I2-...	4	16.0		15	23.5				50	80
AXE110Z	AX-AC-110-SUN-M2	2	31.0	7.0	24	9.3	10	27.5	20		120
AXE160Z	AX-AC-160-SUN-M1	1	30.0	9.5	15	8.5					85
AXE40A	Slider moved AX-AC-40-SUN-I1-...	3	8	28							30
	Profile moved AX-AC-40A-SUN-M2	5	18.0		21						58
AXE60A	Profile moved AX-AC-40A-SUN-I2-...	5	18.0		16						58
	Slider moved AX-AC-60A-SUN-M1-P	1	30.0	9.5	18	55.0					80
	Profile moved AX-AC-60Z-SUN-I2-...	4	16.0		15	50.0					55
	Profile moved AX-AC-80A-SUN-M1-H	5	18.0		30						80
	Profile moved AX-AC-80A-SUN-I2-...	5	18.0		16						80

¹ Length of the actuating element

6.3.4. Technical data

The technical data of the available switches are contained in the Tables 6.24 and 6.25.

Table 6.24 Mechanical limit switches

ID Number Switch mounting set	Life time	Housing material	Cable gland	Conductor cross-section	Protection class
151312	30 x 10 ⁶ switching operations	Plastic	M20 x 1.5	0.5...2.5 mm ²	IP67
156331					
157296					
163876					
353357					
156335	30 x 10 ⁶ switching operations	Plastic	Screwed connection 4 x M3.5	0.5...1.5 mm ²	IP30
164451					
405675					
156336	10 x 10 ⁶ switching operations	Metal	Screwed connection	max. 1.5 mm ²	IP67

Switching segment: Snap-action switch (forced disconnection) each case 1 x opener and 1 x closer each

Table 6.25 Inductive proximity switches

ID - Number Switch mounting set			Connection voltage	Max. load current	Switching accuracy	Cable length	Protection class
PNP-NC	PNP-NO	NPN-NO					
162170	162717	162173	10...30 V DC	100 mA	≤ 2% of the reacting distance	10 m	IP67
161445	154708	161447	10...30 V DC	100 mA	≤ 10% of the reacting distance	5 m	IP67
187110	156345	187109					
162684	156342	152349	12...30 V DC	100 mA	≤ 5% of the reacting distance	2 m	IP67
163249	162687	163250					
166852	163252	166836					
353806	353810	353808					
405715	405716	405717					

6.3.5. Possible switch combinations

The linear axes of the AXE series can be equipped with different limit switches or combinations of different limit switches depending on size. Table 6.26 contains the ID numbers and type codes of the actuating element and the possible limit switch sets, each consisting of one limit switch as well as the fasteners and screws required.

Table 6.26 Possible combination for the switch mounting

Switch version	Type	AXE_Z					AXE_A			
		AXE60Z	AXE80Z	AXE100Z	AXE110Z	AXE160Z	AXE40A Profile moves	AXE40A Slider moves	AXE60A Profile moves	AXE60A Slider moves
Mechanical switches*	IP 67	AX-AC-60-SUN-M3 ID 156336	AX-AC-80-SUN-M1 ID 151312	AX-AC-100-SUN-M1 ID 353357		AX-AC-160-SUN-M1 ID ID 163876			AX-AC-uniA-SUN-M1-H ID 157296	AX-AC-240+60A-SUN-M1-P ID 162588
	Actuating element	AX-AC-60-CSW-M3 ID 156339	AX-AC-80-CSW-M1 ID 152199	AX-AC-100-CSW-M1 ID 406342		AX-AC-160-CSW-M1 ID ID 163869			AX-AC-60A-CSW-P ID 245820	AX-AC-uniA-CSW-H ID 188260
	IP30	AX-AC-60-SUN-M2 ID 156335			AX-AC-110Z-SUN-M2 ID 164451 ¹ AX-AC-110-SUN-M2 ID 164469 ²		AX-AC-40A-SUN-M2 ID 405675			
	Actuating element	AX-AC-60-CSW-M2 ID 158669			AX-AC-110-CSW-M2 ID 164457		AX-AC-40A-CSW-M2 ID 405731			
Inductive proximity switches*	PNP-NC	AX-AC-60Z-SUN-I2-PNP-NC-2m ID 166852	AX-AC-80Z-SUN-I2-PNP-NC-2m ID 162684	AX-AC-100Z-SUN-I2-PNP-NC-2m ID 353806	AX-AC-uni-SUN-I1-PNP-NC-5m ID 161445	AX-AC-40A-SUN-I2-PNP-NC-2m ID 405715	AX-AC-40-SUN-I1-PNP-NC-5m ID 187110	AX-AC-uniA-SUN-I2-PNP-NC-2m ID 163249	AX-AC-60Z-SUN-I2-PNP-NC-2m ID 166852	
	PNP-NO	AX-AC-60Z-SUN-I2-PNP-NO-2m ID 156342	AX-AC-80Z-SUN-I2-PNP-NO-2m ID 162687	AX-AC-100Z-SUN-I2-PNP-NO-2m ID 353810	AX-AC-uni-SUN-I1-PNP-NO-5m ID 154708	AX-AC-40A-SUN-I2-PNP-NO-2m ID 405716	AX-AC-40-SUN-I1-PNP-NO-5m ID 156345	AX-AC-uniA-SUN-I2-PNP-NO-2m ID 163252	AX-AC-60Z-SUN-I2-PNP-NO-2m ID 156342	
	NPN-NO	AX-AC-60Z-SUN-I2-NPN-NO-2m ID 166836	AX-AC-80Z-SUN-I2-NPN-NO-2m ID 152349	AX-AC-100Z-SUN-I2-NPN-NO-2m ID 353808	AX-AC-uni-SUN-I1-NPN-NO-5m ID 161447	AX-AC-40A-SUN-I2-NPN-NO-2m ID 405717	AX-AC-40-SUN-I1-NPN-NO-5m ID 187109	AX-AC-uniA-SUN-I2-NPN-NO-2m ID 163250	AX-AC-60Z-SUN-I2-NPN-NO-2m ID 166836	
	Actuating element	AX-AC-60-CSW-I ID 156339	AX-AC-80-CSW-I ID 152199	AX-AC-100-CSW-I ID 406342		AX-AC-40A-CSW-M2 ID 405731	AX-AC-40-CSW-I ID 156344	AX-AC-60A-CSW-P ID 245820	AX-AC-uniA-CSW-H ID 188260	
Inductive proximity switches (groove installation)	PNP-NC	AX-AC-SUN-GRO-PNP-NC-10m ID 162170							AX-AC-SUN-GRO-PNP-NC-10m ID 162170	
	PNP-NO	AX-AC-SUN-GRO-PNP-NO-10m ID 162717							AX-AC-SUN-GRO-PNP-NO-10m ID 162717	
	NPN-NC	AX-AC-SUN-GRO-NPN-NC-3m ID 162173							AX-AC-SUN-GRO-NPN-NC-3m ID 162173	
	Actuating element	AX-AC-60-CSW-I ID 156338	AX-AC-80-CSW-I ID 152348	AX-AC-100-CSW-I ID 351638					AX-AC-uniA-CSW-I ID 188300	

* When mounting inductive and mechanical switches in combination with each other on one side, only one actuating element is needed.

¹ Mounting on the drive head

² Mounting on the deflection head

6.4 Energy chains

For the AXE linear axis systems suitable energy chains can be offered. Depending on the type, size and requirements there are different types of energy chains available (Table 6.27). The versions differ in the number of separating strips, which are included in every second chain link.

Table 6.27 Energy chains

Type	Number of separating strips	Mean radius	Open		Inner dimension		Max. horizontal self-supported stroke	Filling mass for max. horizontal stroke	Max. horizontal self-supported stroke ¹	Filling mass for max. horizontal stroke ¹	X Axis		Y Axis		Z Axis	
			Inside	Outside	Width	Height					AXE60	AXE80	AXE110	AXE160	AXE40A	AXE60A
		[mm]			[mm]		[mm]	[kg/m]	[mm]	[kg/m]						
B15.5.075	1	75		x	63.0	17.0	1 500	1.0	2 000	0.5	x					
B15.050.075	1	75		x	50.0	17.0	1 500	1.0	2 000	0.5			x			
1400.020.075	2	75	x		20.0	21.0	2 000	2.0	3 000	1.0					x	
2500.07.100.0	2	100		x	77.0	25.0	3 000	2.0	3 700	1.0		x				
1500.068.100.0	2	100		x	68.0	21.0	2 000	2.0	3 000	1.0			x			
B15i.050.100.0	1	100	x		50.0	17.0	1 500	1.0	2 000	0.5						x

6.5 Groove inserts

In ambient conditions with heavy contamination, the profile grooves can be closed with groove inserts (Figure 6.36 and 6.37) to avoid deposits on the linear axes which facilitates the cleaning of these systems considerably.



Figure 6.36 Aluminum groove insert



Figure 6.37 Plastic groove insert

As for linear axes being equipped with inductive proximity switches for groove installation (Chapter 6.3.3), the grooves containing the cable guiding should always be closed with groove inserts.

Table 6.28 specifies the list of available groove inserts.

Table 6.28 Groove inserts

Type	Type code	ID number	Mounting possibility	Material	Color	Length
						[mm]
AXE40	AX-AC-GIN-5-2000-PP	101842	Profile bottom side	Polypropylene	black	2 000
AXE60	AX-AC-GIN-5-2000-PP	101842	all grooves	Polypropylene	black	2 000
AXE80	AX-AC-GIN-6-2000L-PP	101832	all grooves	Polypropylene	black	2 000
	AX-AC-GIN-6-2000-AL	101841		Aluminum anodized	natural	2 000
AXE100	AX-AC-GIN-6-2000L-PP	101832	lateral groove above	Polypropylene	black	2 000
	AX-AC-GIN-6-2000-AL	101841		Aluminum anodized	natural	2 000
	AX-AC-GIN-8-2000-PP	101632	lateral groove below	Polypropylene	black	2 000
	AX-AC-GIN-8-3000L-AL	101822		Aluminum anodized	natural	3 000
AXE110 AXE160	AX-AC-GIN-10-2000-AL	173218	Profile top side	Aluminum anodized	natural	2 000

6.6 Lubrication connections

The actual grease nipple of the linear axes from the AXE series can be replaced if necessary by different types of grease nipples or push-in fittings according to Tables 6.29 and 6.30.

Table 6.29 Dimensions of lubrication connections

Type		Designation	ID Number	MQ	D / Mq	B	N	L
					[mm]	[mm]	[mm]	[mm]
Type 1 Extension		LE-MQ-M6x22.4		M6	M6		13.0	22.4
Type 2 Tube connection straight		PUSH-IN STR M5 D4_0910101	330240	M5	4		4.0	20.0
		LH-M6x5A-4	244379	M6	4		5.0	16.0
		LH-M6x5A-6	244380	M6	6		5.0	17.0
		Push-in fitting-M8x1-D6-straight	295839	M8x1	6		7.0	24.5
Type 3 Tube connection angular		PUSH-IN 90 M5 D4_0911095	352749	M5	4	17.5	4.0	21.0
		Push-in fitting-L-M5-D6	327405	M5	6	20.8	4.0	22.0
		LH-M6x5S-4	270991	M6	4	18.0	5.0	22.5
		LH-M6x5S-6	262033	M6	6	21.0	5.0	22.0
		PUSH-IN-GIR.90 M8X1 TUBO4_3084731	311560	M8x1	4	21.5	8.0	24.0
		PUSH-IN 90 M8X1 D6 - HP_3084752	330086	M8x1	6	24.5	8.0	24.2

Table 6.30 Correlation of the lubrication connections

Linear Axis	Design type standard grease nipple	MQ	Type1		Type2			Type3				
			LE-MQ-M6x22.4	PUSH-IN STR M5 D4_0910101	Tube connection LH-M6x5A-	Tube connection LH-M6x8A-	Push-in fitting-M8x1-D6-straight	PUSH-IN 90 M5 D4_0911095	Push-in fitting-L-M5-D6	Tube connection LH-M6x5S-	Tube connection LH-M6x8S-4	PUSH-IN-GIR.90 M8X1 TUBO4_3084731
AXE60Z	Grease nipple, hydraulic type DIN 71412-A	M8x1					x				x	x
AXE80Z	Grease nipple, hydraulic type DIN 71412-A	M8x1					x				x	x
AXE100Z	Grease nipple, hydraulic type DIN 71412-A	M8x1					x				x	x
AXE110Z	Grease nipple, hydraulic type DIN 71412-A	M5		x				x	x			
AXE160Z	Grease nipple, hydraulic type DIN 71412-A	M6	x		x ¹					x ¹		
AXE40A	Cup head lubricating nipple DIN 3405-A	M6			x							
AXE60A	Cup head lubricating nipple DIN 3405-A	M6				x					x	

x mountable

x¹ only possible in connection with extension Type 1

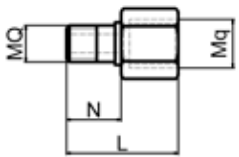
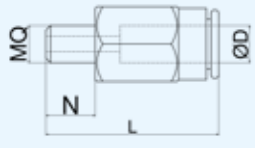
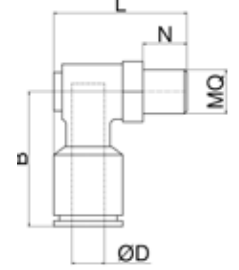
7. Multi Axis Systems

SNR Linear Axis of the AXE series allows the user to create modular standard two and three axis systems (Figure 7.1) with very small design effort. Here there are various possible combinations of the Linear Axis.

The standard axis systems contain the energy chains and the necessary connecting elements. Connecting elements, gearboxes, drive adapter and limit switches can also be selected from the range of accessories (Chapter 6) in order to optimally adapt the system to the requirements of the application.

Furthermore, it is also possible to customize two- and three-axis systems.

The descriptions and ID numbers of the required direct, portal, cross and A-standard connections and their combinations as well as the drive adaptations and other accessories are included in Chapter 6 «Accessories».

All standard axis systems are configurable online.

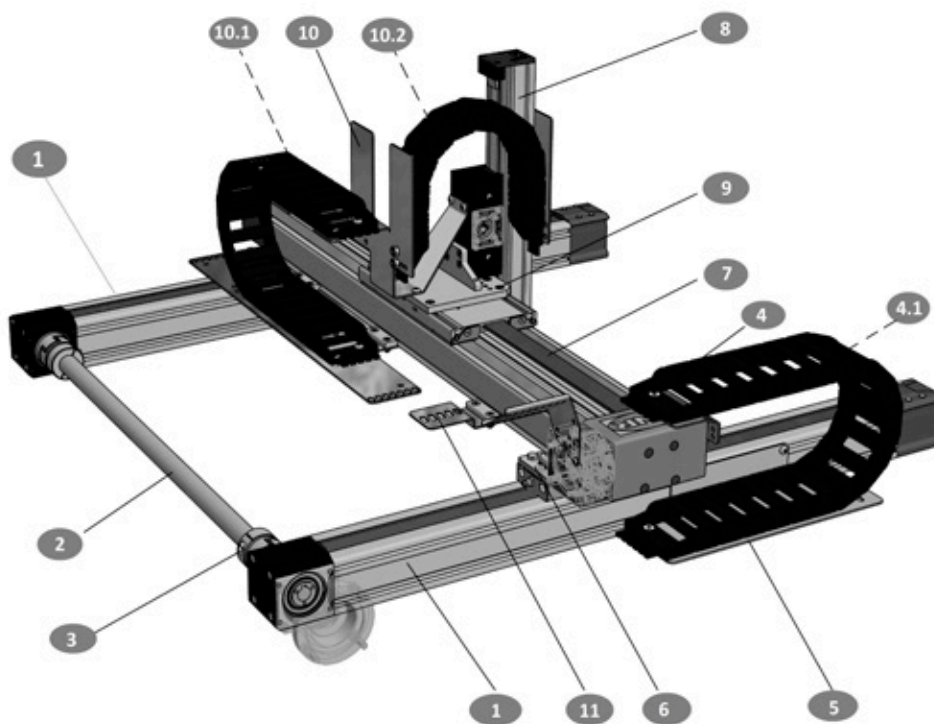

Figure 7.1 Standard Axis System

7.1 Standard Axis System

In the standard axis system, the SNR linear axes are combined into two-axis systems in an x-y or y-z arrangement or three-axis systems. The travel range of the axis can be selected according to the specifications given in chapters 5.2.2 and 5.3.2 up to the maximum length of the energy chain. The energy chains are set for standard strokes according to Table 7.1 in Chapter 7.1.1 and Table 7.2 in Chapter 7.1.2. By removing chain links, the energy chains can be adapted to shorter strokes or to longer strokes by inserting additional chain links.

Additional components, such as gearboxes, motor adapters, couplings for the drives and limit switches, can be selected as specified in Chapters 6.2 and 6.3.

7.1.1. Standard Axis System A

In the standard axis system A, the SNR linear axes AXE60Z, AXE110Z and AXE40A are combined into two-axis systems in an x-y or y-z arrangement or three-axis systems.

Table 7.1 contains the necessary components for the configuration of the standard axis system A.

Table 7.1 Standard Axis Systems A

Axis System		No.	Axis System A					
			Type code	Description	ID Number	Quantity	Remark	
Standard 3- Axis - System XYZ	Standard 2 Axis - System XY	1	AXE60Z14-B- [Travel range]	Base Axis X	Chapter 5.2.2	2	maximum travel range 2140 mm	
		2	AX-AC-CHS-22- [Shaft length]	Connecting shaft L = Stroke Y + 45 mm	Chapter 6.2.2	1		
		3	AX-AC-COU-CHS-22	Coupling set connecting shaft	292876	2		
		4	AX-AC-ECU-60-110Z	Energy chain unit XY	292876	1	Standard length for X travel range ≤ 1000 mm, shortened (60 mm travel range per chain link)	
		4.1	AX-AC-ECL-B15.5.075	Additional energy chain link for X Axis	459259	max. 17	60 mm travel range per chain link	
		5	AX-AC-ECS-60X	Energy chain support	459261		for X travel range > 1000 mm	
		Standard 2 Axis - System YZ	6	AX-AC-DCU-60-110-E	Axis connection XY	459272	2	
			7	AXE110Z16-D- [Travel range]	Base Axis Y	459273	1	maximum travel range 2060 mm
			8	AXC40A10-B- [Travel range]	Base Axis Z	Chapter 5.2.2	1	
			9	AX-AC-SCU-110-40	Axis connection YZ	327403	1	
			10	AX-AC-ECU-110-40A	Energy chain unit YZ	459275	1	Standard length for Y travel range 200...500 mm and Z travel range ≤ 200 mm, shortened (60 mm travel range per chain link)
		10.1	AX-AC-ECL-B15.050.075	Additional energy chain link for Y Axis	459266	max. 24	60 mm travel range per chain link	
		10.2	AX-AC-ECL-1400.020.075	Additional energy chain link for Z Axis	459268	max. 11	60 mm travel range per chain link	
		11	AX-AC-CGU-A-Y	Cable guiding Y Axis	459276		Stroke > 500 mm	

7.1.2. Standard Axis System B

In the standard axis system B, the SNR linear axes AXE80Z, AXE160Z and AXE60A are combined into two-axis systems in an x-y or y-z arrangement or three-axis systems.

Table 7.2 contains the necessary components for the configuration of the standard axis system B.

Table 7.2 Standard Axis Systems B

Axis System	No.	Axis System B					
		Type code	Description	ID Number	Quantity	Remark	
Standard 3- Axis - System XYZ	Standard 2 Axis - System XY	1	AXE80Z20-B- [Travel range]	Base Axis X	Chapter 5.2.2	2	maximum travel range 3540 mm
		2	AX-AC-CHS-28- [Shaft length]	Connecting shaft L = Stroke Y + 37 mm	Chapter 6.2.2	1	
		3	AX-AC-COU-CHS-28	Coupling set connecting shaft	153844	2	
		4	AX-AC-ECU-80-160Z	Energy chain unit XY	459278	1	Standard length for X travel range 480...≤ 2100 mm, shortened (92 mm travel range per chain link)
		4.1	AX-AC-ECL-2500.07.100.0	Additional energy chain link for X Axis	289015	max. 16	92 mm travel range per chain link
		5	AX-AC-ECS-80X	Energy chain support	459279	max. 1	for X travel range > 2100 mm
	Standard 2 Axis - System YZ	6	AX-AC-DCU-80-160-E	Axis connection XY	459281	2	
		7	AXE160Z25-D- [Travel range]	Base Axis Y	Chapter 5.2.2	1	maximum travel range 3000 mm
		8	AXC60A14-B- [Travel range]	Base Axis Z	Chapter 5.2.2	1	maximum travel range 2020 mm
		9	AX-AC-SCU-160-60	Axis connection YZ	458059	1	
		10	AX-AC-ECU-160-60A	Energy chain unit YZ	459282	1	Standard length for Y travel range 480...1020 mm and Z travel range ≤ 520 mm, shortened (66 mm Y travel range, 30 mm Z travel range per chain link)
	10.1	AX-AC-ECL-1500.068.100.0	Additional energy chain link for Y Axis	459270	max. 30	66 mm travel range per chain link	
	10.2	AX-AC-ECL-B15i.050.100.0	Additional energy chain link for Z Axis	459269	max. 50	30 mm travel range per chain link	
	11	AXE-AC-CGU-B-Y	Cable guiding Y Axis	459318		Travel range ≥ 1140 mm (recommendation: +1 for each 600 mm travel range)	

7.2 Dynamic load capacity of Standard Axis Systems

The dynamic load capacity of axis systems is limited mainly by the deformation of the y axis caused by the dynamics of the z axis. The diagram in Figure 7.2 shows the load limits of the standard axis systems as a function of the stroke lengths of the y and z axis and the permissible dynamic load capacity. Applications with high accelerations above 5 m/s² are only sensible for the standard axis system B with short strokes of the z axis. When determining the dynamic load capacity, the permanent weight of the moving axis does not need to be considered.

Figure 7.2 Dynamic load capacities of Standard Axis Stems

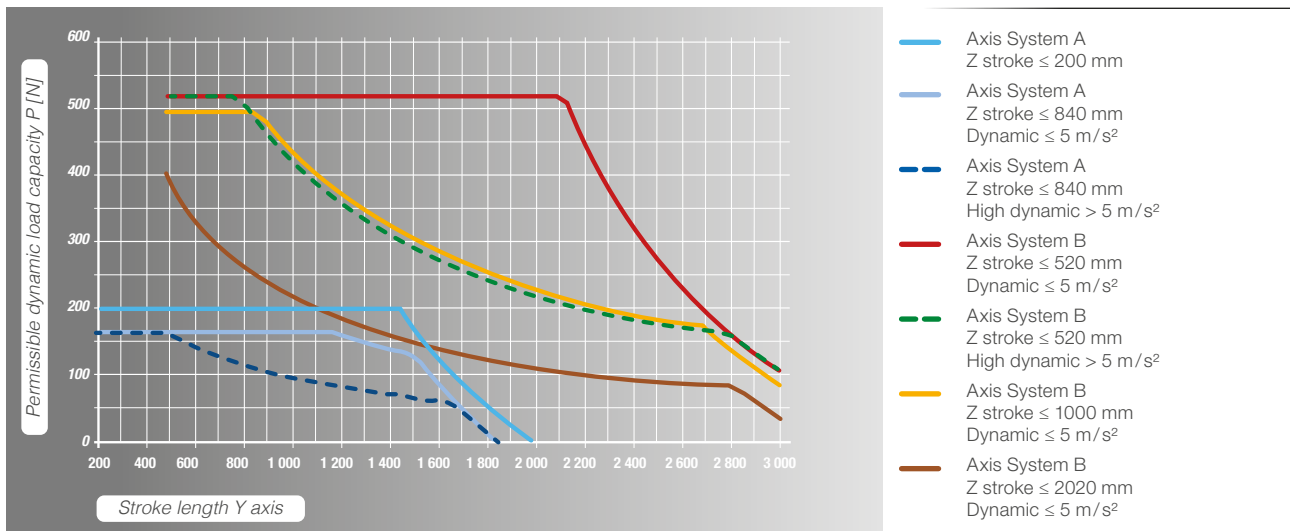

Example:

- Load m : 10 kg
- Y stroke: 1500 mm
- Z stroke: 300 mm
- Acceleration a of the Z axis: 25 m/s²

- Dynamic load capacity: $P = m \times a$
 $P = 10 \text{ kg} \times 25 \text{ m/s}^2$
 $P = 250 \text{ N}$

In the diagram of Figure 7.3, which was restricted to the high dynamic curves, the intersection point of the 1500 mm y-axis stroke and the 250 N dynamic load capacity is just below the curve for an axis system B with a z-stroke of ≤ 520 mm. Thus, this application can be realized with an axis system B.

Figure 7.3 Dynamic load capacities of Standard Axis Stems with high dynamic

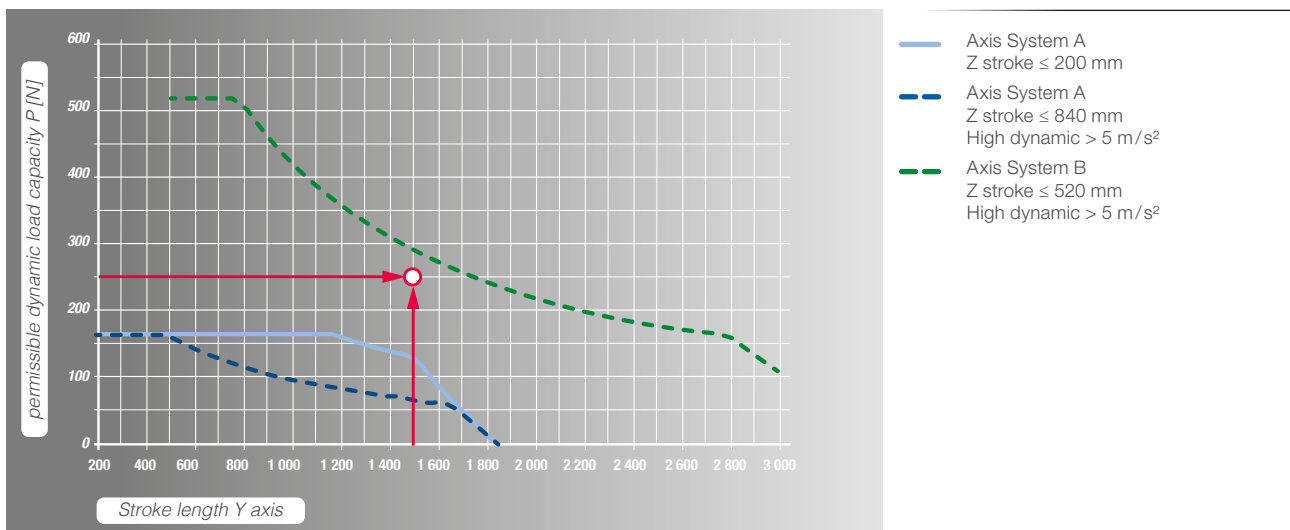

7.3 Limit switch combinations for Standard Axis Systems

For standard axis systems limit switch combinations are specified in Table 7.3. These switch combinations can be configured online.

Other limit switches or combinations of switches can be selected individually and be configured online.

Table 7.3 Limit switch combinations for Standard Axis Systems

Designation
without
2 mechanical switches
2 mechanical switches + 1 reference switch PNP
2 mechanical switches + 1 reference switch NPN
2 inductive proximity switches + 1 reference switch PNP
2 inductive proximity switches PNP-NC
1 inductive proximity switch PNP-NO
1 inductive proximity switch NPN-NO
2 inductive proximity switches NPN-NO
3 inductive proximity switches NPN-NO

8. Type code

AXE	60	Z	14	-	B	-	1000
1	2	3	4		5		6

1	AXE	Series
2	60	Size
3	Z	Drive type A: toothed belt / Ω - drive Z: toothed belt drive
4	14	Size index for toothed belt drive Hollow shaft diameter
5	B	Guiding system B: one Linear Guide, standard table C: one Linear Guide, long table D: two parallel Linear Guides, standard table
6	1000	Travel range [mm]

9. Type list / ID Number list

Table 9.1 contains an overview of the used type codes and Table 9.2 an overview of the ID numbers of the accessories and spare parts.

Table 9.1 Type list

Type code	Designation	Page
AX...-SP-CST	Cover strip	35
AX...-SP-WPS	Wear part set	35
AX-AC-...-COU-K-...	Clamping hub coupling	65, 66
AX-AC-...-CSW-	Actuating element for limit switches	80, 81
AX-AC-...-DAD-...	Adapter for form-fitted gearbox assembly	72
AX-AC-...-DAE-...	Adapter for form-fitted gearbox assembly	72
AX-AC-...-PSH-...	Plug-in shafts	64
AX-AC-...-SUN-...	Plug-in shaft set	80, 81
AX-AC-ACU-...	Angle connection	62, 63
AX-AC-CCO-...	Coupling and coupling cone	73, 74
AX-AC-CCU-...	Cross connection	59
AX-AC-CHS-...	Connecting shaft	67 - 69
AX-AC-COU-CHS...	Coupling unit for connecting shaft	65
AX-AC-DCU-...	Direct connection	58
AX-AC-ECL-...	Energy chain link	85
AX-AC-ECS-...	Energy chain support	85
AX-AC-ECU-...	Energy chain unit	85
AX-AC-FST-...	Fastening strip	56
AX-AC-GCU-...	Gantry connection	60
AX-AC-GIN-...	Groove insert	82
AX-AC-MAU-E...	Motor adapter	71
AX-AC-PGE-...	Planetary gearbox	70, 72, 74
AX-AC-SBL-...	Sliding block	57
AX-AC-SCU-...	A-standard connection	61
AXE-AC-CGU-...	Cable guiding	85

Table 9.2 ID Number list

ID Number	Type code	Designation	Chapter
101632	AX-AC-GIN-8-2000-PP	Groove insert, plastic	6.5
101822	AX-AC-GIN-8-3000L-AL	Groove insert, aluminum	6.5
101832	AX-AC-GIN-6-2000L-PP	Groove insert, plastic	6.5
101841	AX-AC-GIN-6-2000-AL	Groove insert, aluminum	6.5
101842	AX-AC-GIN-5-2000-PP	Groove insert, plastic	6.5
103758	AX-AC-SBL-5-M3-R-Zi	Sliding block, design type R	6.1.2
108075	AX-AC-FST-70x20-2	Fastening strip	6.1.1
108579	AX-AC-FST-40x10-3	Fastening strip	6.1.1
108663	AX-AC-FST-40x13-2	Fastening strip	6.1.1
109066	AX-AC-SBL-5ST-M3-E	Sliding block, design type E	6.1.2
109070	AX-AC-SBL-5ST-M5-E	Sliding block, design type E	6.1.2
109073	AX-AC-SBL-5ST-M4-E	Sliding block, design type E	6.1.2
109091	AX-AC-SBL-6ST-M6-E	Sliding block, design type E	6.1.2
109093	AX-AC-SBL-6ST-M5-E	Sliding block, design type E	6.1.2
109094	AX-AC-SBL-6ST-M4-E	Sliding block, design type E	6.1.2
110236	AX-AC-FST-78x22-2	Fastening strip	6.1.1
139275	AX-AC-SBL-5ST-M5-E-A2	Sliding block, design type E	6.1.2
149812	AX-AC-SBL-8-ST-M8-F	Sliding block, design type F	6.1.2
150822	AX-AC-FST-47x7-2	Fastening strip	6.1.1
151312	AX-AC-80-SUN-M1	Mechanical limit switch	6.3.5
151341	AX-AC-80ZA-COU-K-20	Clamping hub coupling	6.2.2
152199	AX-AC-80-CSW-M1	Actuating element	6.3.5
152199	AX-AC-80-CSW-I	Actuating element	6.3.5
152348	AX-AC-80-CSW-I	Actuating element	6.3.5
152349	AX-AC-80Z-SUN-I2-NPN-NO-2m	Inductive proximity switch	6.3.5
152373	AX-AC-80ZA-PSH-S	Plug-in shaft	6.2.1
153844	AX-AC-80Z-COU-CHS-28	Coupling set for connecting shafts	6.2.2
153960	AX-AC-80ZA-PSH-D	Plug-in shaft	6.2.1
154708	AX-AC-uni-SUN-I1-PNP-NO-5m	Inductive proximity switch	6.3.5
154897	AX-AC-160Z-CCO-A-20	Drive adaption via coupling and coupling cone	6.2.3.2
156270	AX-AC-40ZA-PSH-S	Plug-in shaft	6.2.1
156300	AX-AC-SCU-80-60	A - Standard connection	6.1.6
156335	AX-AC-60-SUN-M2	Mechanical limit switch	6.3.5
156336	AX-AC-60-SUN-M3	Mechanical limit switch	6.3.5
156338	AX-AC-60-CSW-I	Actuating element	6.3.5
156339	AX-AC-60-CSW-M3	Actuating element	6.3.5
156339	AX-AC-60-CSW-I	Actuating element	6.3.5
156342	AX-AC-60Z-SUN-I2-PNP-NO-2m	Inductive proximity switch	6.3.5
156344	AX-AC-40-CSW-I	Actuating element	6.3.5
156345	AX-AC-40-SUN-I1-PNP-NO-5m	Inductive proximity switch	6.3.5
157296	AX-AC-uniA-SUN-M1-H	Mechanical limit switch	6.3.5
158669	AX-AC-60-CSW-M2	Actuating element	6.3.5
158840	AX-AC-CCU-80-60	Cross connection	6.1.4
160340	AX-AC-160Z-CCO-C-22	Drive adaption via coupling and coupling cone	6.2.3.2
160635	AX-AC-CCU-60-60	Cross connection	6.1.4
160928	AX-AC-80ZA-CCO-A-19	Drive adaption via coupling and coupling cone	6.2.3.2
160929	AX-AC-80ZA-CCO-A-20	Drive adaption via coupling and coupling cone	6.2.3.2
160930	AX-AC-80ZA-CCO-A-24	Drive adaption via coupling and coupling cone	6.2.3.2
160931	AX-AC-80ZA-CCO-A-25	Drive adaption via coupling and coupling cone	6.2.3.2
160984	AX-AC-80ZA-CCO-B-19	Drive adaption via coupling and coupling cone	6.2.3.2
160987	AX-AC-80ZA-CCO-B-20	Drive adaption via coupling and coupling cone	6.2.3.2
161016	AX-AC-80ZA-CCO-C-20	Drive adaption via coupling and coupling cone	6.2.3.2
161043	AX-AC-80ZA-CCO-D-16	Drive adaption via coupling and coupling cone	6.2.3.2
161046	AX-AC-80ZA-CCO-E-22	Drive adaption via coupling and coupling cone	6.2.3.2

ID Number	Type code	Designation	Chapter
161308	AX-AC-80ZA-CCO-F-20	Drive adaption via coupling and coupling cone	6.2.3.2
161308	AX-AC-CCO80-Z-A-GS20-F	Adapter for drive adaption via coupling and coupling cone	6.2.3.2
161445	AX-AC-uni-SUN-I1-PNP-NC-5m	Inductive proximity swtich	6.3.5
161447	AX-AC-uni-SUN-I1-NPN-NO-5m	Inductive proximity swtich	6.3.5
162170	AX-AC-SUN-GRO-PNP-NC-10m	Inductive proximity swtich	6.3.5
162173	AX-AC-SUN-GRO-NPN-NC-3m	Inductive proximity swtich	6.3.5
162588	AX-AC-240+60A-SUN-M1-P	Mechanical limit switch	6.3.5
162684	AX-AC-80Z-SUN-I2-PNP-NC-2m	Inductive proximity swtich	6.3.5
162687	AX-AC-80Z-SUN-I2-PNP-NO-2m	Inductive proximity swtich	6.3.5
162717	AX-AC-SUN-GRO-PNP-NO-10m	Inductive proximity swtich	6.3.5
163249	AX-AC-uniA-SUN-I2-PNP-NC-2m	Inductive proximity swtich	6.3.5
163250	AX-AC-uniA-SUN-I2-NPN-NO-2m	Inductive proximity swtich	6.3.5
163252	AX-AC-uniA-SUN-I2-PNP-NO-2m	Inductive proximity swtich	6.3.5
163809	AX-AC-160Z-CCO-B-16	Drive adaption via coupling and coupling cone	6.2.3.2
163869	AX-AC-160-CSW-M1	Actuating element	6.3.5
163876	AX-AC-160-SUN-M1	Mechanical limit switch	6.3.5
164451	AX-AC-110Z-SUN-M2	Mechanical limit switch	6.3.5
164457	AX-AC-110-CSW-M2	Actuating element	6.3.5
164469	AX-AC-110-SUN-M2	Mechanical limit switch	6.3.5
164502	AX-AC-110Z-CCO-C-16	Drive adaption via coupling and coupling cone	6.2.3.2
165758	AX-AC-60ZA-DAD-C	Adapter for form-fitted gearbox mounting	6.2.3.1
166836	AX-AC-60Z-SUN-I2-NPN-NO-2m	Inductive proximity swtich	6.3.5
166852	AX-AC-60Z-SUN-I2-PNP-NC-2m	Inductive proximity swtich	6.3.5
167332	AX-AC-DCU-80-160	Direct connection	6.1.3
168623	AX-AC-80ZA-DAD-E	Adapter for form-fitted gearbox mounting	6.2.3.1
169154	AX-AC-GCU-80-160	Gantry connection	6.1.5
169160	AX-AC-CCU-160-80	Cross connection	6.1.4
169893	AX-AC-60ZA-CCO-A-16	Drive adaption via coupling and coupling cone	6.2.3.2
171476	AX-AC-80ZA-COU-K-18	Clamping hub coupling	6.2.2
171711	AX-AC-60ZA-CCO-E-19	Drive adaption via coupling and coupling cone	6.2.3.2
171712	AX-AC-60ZA-CCO-E-20	Drive adaption via coupling and coupling cone	6.2.3.2
173137	AX-AC-160Z-CCO-D-20	Drive adaption via coupling and coupling cone	6.2.3.2
173137	AX-AC-CCO160-Z-D	Adapter for drive adaption via coupling and coupling cone	6.2.3.2
173218	AX-AC-GIN-10-2000-AL	Groove insert, aluminum	6.5
173218	AX-AC-GIN-10-2000-AL	Groove insert, aluminum	6.5
173421	AX-AC-DCU-60-110	Direct connection	6.1.3
183464	AX-AC-110Z-CCO-E-14	Drive adaption via coupling and coupling cone	6.2.3.2
183464	AX-AC-CCO110-Z-MP060	Adapter for drive adaption via coupling and coupling cone	6.2.3.2
183942	AX-AC-SBL-8-ST-M6-F	Sliding block, design type F	6.1.2
184826	AX-AC-80ZA-COU-K-25	Clamping hub coupling	6.2.2
185644	AX-AC-60ZA-COU-K-20	Clamping hub coupling	6.2.2
185836	AX-AC-160Z-CCO-E-25	Drive adaption via coupling and coupling cone	6.2.3.2
185844	AX-AC-160Z-CCO-E-30	Drive adaption via coupling and coupling cone	6.2.3.2
186857	AX-AC-40ZA-CCO-A-09	Drive adaption via coupling and coupling cone	6.2.3.2
186859	AX-AC-40ZA-CCO-A-08	Drive adaption via coupling and coupling cone	6.2.3.2
187109	AX-AC-40-SUN-I1-NPN-NO-5m	Inductive proximity swtich	6.3.5
187110	AX-AC-40-SUN-I1-PNP-NC-5m	Inductive proximity swtich	6.3.5
187161	AX-AC-60ZA-CCO-I-14	Drive adaption via coupling and coupling cone	6.2.3.2
187161	AX-AC-CCO60-Z-A-G14-I	Adapter for drive adaption via coupling and coupling cone	6.2.3.2
187181	AX-AC-80ZA-COU-K-16	Clamping hub coupling	6.2.2
187286	AX-AC-80ZA-DAD-A	Adapter for form-fitted gearbox mounting	6.2.3.1
187407	AX-AC-60ZA-PSH-S	Plug-in shaft	6.2.1
188209	AX-AC-60ZA-COU-K-14	Clamping hub coupling	6.2.2
188260	AX-AC-uniA-CSW-H	Actuating element	6.3.5
188300	AX-AC-uniA-CSW-I	Actuating element	6.3.5

ID Number	Type code	Designation	Chapter
188958	AX-AC-60ZA-COU-K-19	Clamping hub coupling	6.2.2
189202	AX-AC-60ZA-PSH-D	Plug-in shaft	6.2.1
190466	AX-AC-60ZA-DAD-A	Adapter for form-fitted gearbox mounting	6.2.3.1
203284	AX-AC-160Z-COU-K-30	Clamping hub coupling	6.2.2
203284	AX-AC-160Z-COU-K-38	Clamping hub coupling	6.2.2
203392	AX-AC-SBL-6ST-M6-E-A2	Sliding block, design type E	6.1.2
206005	AX-AC-160Z-PSH-S	Plug-in shaft	6.2.1
207896	AX-AC-DCU-80-120	Direct connection	6.1.3
207936	AX-AC-DCU-110-110	Direct connection	6.1.3
230147	AX-AC-DCU-60-60	Direct connection	6.1.3
230361	AX-AC-GCU-60-110	Gantry connection	6.1.5
230511	AX-AC-60ZA-COU-K-16	Clamping hub coupling	6.2.2
230960	AX-AC-80ZA-CCO-B-25	Drive adaption via coupling and coupling cone	6.2.3.2
233232	AX-AC-60ZA-COU-K-10	Clamping hub coupling	6.2.2
238803	AX-AC-160Z-COU-K-22	Clamping hub coupling	6.2.2
239690	AX-AC-40ZA-DAD-C	Adapter for form-fitted gearbox mounting	6.2.3.1
244379	LH-M6x5A-4	Tube connection straight	6.6
244380	LH-M6x5A-6	Tube connection straight	6.6
244920	AX-AC-80ZA-CCO-C-14	Drive adaption via coupling and coupling cone	6.2.3.2
245820	AX-AC-60A-CSW-P	Actuating element	6.3.5
245820	AX-AC-60A-CSW-P	Actuating element	6.3.5
247474	AX-AC-80ZA-COU-K-22	Clamping hub coupling	6.2.2
251324	AX-AC-160Z-COU-K-20	Clamping hub coupling	6.2.2
251343	AX-AC-80ZA-COU-K-14	Clamping hub coupling	6.2.2
251662	AX-AC-80ZA-COU-K-19	Clamping hub coupling	6.2.2
252537	AX-AC-CCU-110-60	Cross connection	6.1.4
253556	AX-AC-CCU-80-80	Cross connection	6.1.4
253672	AX-AC-110Z-CCO-F-20	Drive adaption via coupling and coupling cone	6.2.3.2
255069	AX-AC-SBL-6-ST-M4-F	Sliding block, design type F	6.1.2
255070	AX-AC-SBL-6-ST-M6-F	Sliding block, design type F	6.1.2
257591	AX-AC-80ZA-COU-K-12	Clamping hub coupling	6.2.2
258785	AX-AC-SBL-8-ST-M5-F	Sliding block, design type F	6.1.2
259405	AX-AC-CCU-110-110	Cross connection	6.1.4
262033	LH-M6x5S-6	Tube connection angular	6.6
264974	AX-AC-CCU-160-160	Cross connection	6.1.4
265454	AX-AC-GCU-60-160	Gantry connection	6.1.5
265455	AX-AC-CCU-160-60	Cross connection	6.1.4
267710	AX-AC-ACU-Y160-Z110T	Angle connection	6.1.7
268344	AX-SP-110-A-WPS	Wear part set	4.9
268345	AX-SP-160-A-WPS	Wear part set	4.9
268606	AX-AC-SCU-110-60	A - Standard connection	6.1.6
269049	AX-AC-ACU-Y160-Z110P	Angle connection	6.1.7
270991	LH-M6x5S-4	Tube connection angular	6.6
281274	AX-AC-DCU-110-60	Direct connection	6.1.3
284121	AX-AC-100Z-COU-CHS-38	Coupling set for connecting shafts	6.2.2
286227	AX-AC-ACU-X160-Y110P	Angle connection	6.1.7
288848	AX-AC-DCU-160-80	Direct connection	6.1.3
289015	AX-AC-ECL-2500.07.100.0	Energy chain link	7.1.1
289073	AX-AC-SBL-5ST-M4-E-A2	Sliding block, design type E	6.1.2
292876	AX-AC-60Z-COU-CHS-22	Coupling set for connecting shafts	6.2.2
295839	Push-in fitting-M8x1-D6-straight	Tube connection straight	6.6
299881	AX-AC-SCU-60-40	A - Standard connection	6.1.6
304052	AX-AC-160Z-COU-K-25	Clamping hub coupling	6.2.2
306559	AX-AC-ACU-X160-Y160	Angle connection	6.1.7
306666	AX-AC-ACU-160-160-2	Angle connection	6.1.7

ID Number	Type code	Designation	Chapter
308746	AX-AC-110Z-PSH-S	Plug-in shaft	6.2.1
308879	AX-AC-DCU-160-160	Direct connection	6.1.3
308887	AX-AC-110Z-CCO-A-20	Drive adaption via coupling and coupling cone	6.2.3.2
311560	PUSH-IN-GIR.90 M8X1 TUBO4_3084731	Tube connection angular	6.6
327403	AX-AC-SCU-110-40	A - Standard connection	6.1.6
327405	Push-in fitting- L-M5-D6	Tube connection angular	6.6
330086	PUSH-IN 90 M8X1 D6 - HP_3084752	Tube connection angular	6.6
330240	PUSH-IN STR M5 D4_0910101	Tube connection straight	6.6
351593	AX-AC-CCU-160-110	Cross connection	6.1.4
351638	AX-AC-100-CSW-I	Actuating element	6.3.5
352749	PUSH-IN 90 M5 D4_0911095	Tube connection angular	6.6
353280	AX-AC-SBL-6-ST-M5-F	Sliding block, design type F	6.1.2
353357	AX-AC-100-SUN-M1	Mechanical limit switch	6.3.5
353806	AX-AC-100Z-SUN-I2-PNP-NC-2m	Inductive proximity swtich	6.3.5
353808	AX-AC-100Z-SUN-I2-NPN-NO-2m	Inductive proximity swtich	6.3.5
353810	AX-AC-100Z-SUN-I2-PNP-NO-2m	Inductive proximity swtich	6.3.5
357642	AX-AC-DCU-160-110	Direct connection	6.1.3
363425	AX-AC-ACU-Y110-Z110	Angle connection	6.1.7
373054	AX-AC-ACU-X160-Y110T	Angle connection	6.1.7
382288	AX-AC-DCU-160-60	Direct connection	6.1.3
382293	AX-AC-ACU-110-110	Angle connection	6.1.7
382301	AX-AC-ACU-Y160-Z160	Angle connection	6.1.7
400616	AX-AC-100Z-CCO-A-20	Drive adaption via coupling and coupling cone	6.2.3.2
400748	AX-AC-100Z-CCO-B-30	Drive adaption via coupling and coupling cone	6.2.3.2
400753	AX-AC-100Z-CCO-A-25	Drive adaption via coupling and coupling cone	6.2.3.2
400753	AX-AC-CCO100-Z-G25-A	Adapter for drive adaption via coupling and coupling cone	6.2.3.2
400756	AX-AC-100Z-CCO-C-22	Drive adaption via coupling and coupling cone	6.2.3.2
400760	AX-AC-100Z-DAE-B	Adapter for form-fitted gearbox mounting	6.2.3.1
405675	AX-AC-40A-SUN-M2	Mechanical limit switch	6.3.5
405715	AX-AC-40A-SUN-I2-PNP-NC-2m	Inductive proximity swtich	6.3.5
405716	AX-AC-40A-SUN-I2-NPN-NO-2m	Inductive proximity swtich	6.3.5
405717	AX-AC-40A-SUN-I2-PNP-NO-2m	Inductive proximity swtich	6.3.5
405731	AX-AC-40A-CSW-M2	Actuating element	6.3.5
406342	AX-AC-100-CSW-M1	Actuating element	6.3.5
406342	AX-AC-100-CSW-I	Actuating element	6.3.5
409338	AX-AC-100Z-DAE-A	Adapter for form-fitted gearbox mounting	6.2.3.1
409353	AX-AC-110Z-COU-K-12	Clamping hub coupling	6.2.2
409354	AX-AC-110Z-COU-K-20	Clamping hub coupling	6.2.2
409355	AX-AC-110Z-COU-K-22	Clamping hub coupling	6.2.2
409633	AX-AC-100Z-PSH-D	Plug-in shaft	6.2.1
409634	AX-AC-100Z-PSH-S	Plug-in shaft	6.2.1
409852	AX-AC-100Z-CCO-B-25	Drive adaption via coupling and coupling cone	6.2.3.2
410937	AX-AC-100Z-DAE-C	Adapter for form-fitted gearbox mounting	6.2.3.1
449876	AX-AC-40ZA-PSH-D	Plug-in shaft	6.2.1
458059	AX-AC-SCU-160-60	A - Standard connection	6.1.6
459259	AX-AC-ECU-60-110Z	Energy chain unit	7.1.1
459261	AX-AC-ECL-B15.5.075	Energy chain link	7.1.1
459266	AX-AC-ECL-B15.050.075	Energy chain link	7.1.1
459268	AX-AC-ECL-1400.020.075	Energy chain link	7.1.1
459269	AX-AC-ECL-B15i.050.100.0	Energy chain link	7.1.1
459270	AX-AC-ECL-1500.068.100.0	Energy chain link	7.1.1
459272	AX-AC-ECS-60X	Energy chain support	7.1.1
459273	AX-AC-DCU-60-110-E	Direct connection for standard axis systems	7.1.1
459275	AX-AC-ECU-110-40A	Energy chain unit	7.1.1
459276	AX-AC-CGU-A-Y	Cable guiding	7.1.1

ID Number	Type code	Designation	Chapter
459278	AX-AC-ECU-80-160Z	Energy chain unit	7.1.1
459279	AX-AC-ECS-80X	Energy chain support	7.1.1
459281	AX-AC-DCU-80-160-E	Direct connection for standard axis systems	7.1.1
459282	AX-AC-ECU-160-60A	Energy chain unit	7.1.1
459318	AX-AC-CGU-B-Y	Cable guiding	7.1.1
459772	AX-SP-CST-U-19,0-1M	Cover strip	4.9
459876	AX-AC-ACU-X110-Y110	Angle connection	6.1.7
461092	AX-SP-CST-U-19,0-2M	Cover strip	4.9
461093	AX-SP-CST-U-19,0-3M	Cover strip	4.9
461094	AX-SP-CST-U-19,0-4M	Cover strip	4.9
461096	AX-SP-CST-U-19,0-5M	Cover strip	4.9
461097	AX-SP-CST-U-19,0-6M	Cover strip	4.9
461098	AX-SP-CST-U-19,0-7M	Cover strip	4.9
468209	AX-AC-MAU-E63-B40-D9x20-M4-C9	Motor adapter	6.2.3
468215	AX-AC-MAU-E63-B40-D9x20-M5-C14	Motor adapter	6.2.3
468217	AX-AC-MAU-E95-B50-D14x30-M6-C14	Motor adapter	6.2.3
468218	AX-AC-MAU-E70-B50-D14x30-M5-C14	Motor adapter	6.2.3
468219	AX-AC-MAU-E75-B60-D14x30-M5-C14	Motor adapter	6.2.3
468220	AX-AC-MAU-E95-B50-D14x30-M6-C19	Motor adapter	6.2.3
468221	AX-AC-MAU-E70-B50-D14x30-M5-C19	Motor adapter	6.2.3
468223	AX-AC-MAU-E90-B70-D19x40-M5-C19	Motor adapter	6.2.3
468225	AX-AC-MAU-E100-B80-D19x40-M6-C19	Motor adapter	6.2.3
468226	AX-AC-MAU-E115-B95-D19x40-M8-C19	Motor adapter	6.2.3
468228	AX-AC-MAU-E75-B60-D11x23-M5-C19	Motor adapter	6.2.3
468229	AX-AC-MAU-E75-B60-D14x30-M5-C19	Motor adapter	6.2.3
468230	AX-AC-MAU-E100-B80-D14x30-M6-C19	Motor adapter	6.2.3
468231	AX-AC-MAU-E75-B60-D14x30-M5-C24	Motor adapter	6.2.3
468232	AX-AC-MAU-E95-B50-D14x30-M6-C24	Motor adapter	6.2.3
468233	AX-AC-MAU-E100-B80-D14x30-M6-C24	Motor adapter	6.2.3
468235	AX-AC-MAU-E115-B95-D19x40-M8-C24	Motor adapter	6.2.3
468240	AX-AC-MAU-E130-B110-D19x40-M8-C24	Motor adapter	6.2.3
468327	AX-AC-MAU-E130-B110-D24x50-M8-C24	Motor adapter	6.2.3
468329	AX-AC-MAU-E130-B95-D19x40-M8-C24	Motor adapter	6.2.3
468331	AX-AC-MAU-E130-B95-D24x50-M8-C24	Motor adapter	6.2.3
468332	AX-AC-PGE040-010-C9	Planetary gearbox	6.2.3
468334	AX-AC-PGE060-010-C14	Planetary gearbox	6.2.3
468335	AX-AC-PGE060-005-C19	Planetary gearbox	6.2.3
468336	AX-AC-PGE080-005-C19	Planetary gearbox	6.2.3
468337	AX-AC-PGE080-010-C19	Planetary gearbox	6.2.3
468338	AX-AC-PGE115-005-C24	Planetary gearbox	6.2.3
468339	AX-AC-PGE115-010-C24	Planetary gearbox	6.2.3
on request	AX-AC-100Z-COU-K-20	Clamping hub coupling	6.2.2
on request	AX-AC-100Z-COU-K-22	Clamping hub coupling	6.2.2
on request	AX-AC-100Z-COU-K-25	Clamping hub coupling	6.2.2
on request	AX-AC-100Z-COU-K-30	Clamping hub coupling	6.2.2
on request	AX-AC-100Z-COU-K-38	Clamping hub coupling	6.2.2
on request	AX-AC-110Z-COU-K-25	Clamping hub coupling	6.2.2



10. Fits

Shaft tolerances [μm]

over	up to	d9	e8	f7	f6	f5	g6	g5	h5	h6	h7	h8	h9	h10
-	3	-20	-14	-6	-6	-6	-2	-2	0	0	0	0	0	0
		-45	-28	-16	-12	-10	-8	-6	-4	-6	-10	-14	-25	-40
3	6	-30	-20	-10	-10	-10	-4	-4	0	0	0	0	0	0
		-60	-38	-22	-18	-15	-12	-9	-5	-8	-12	-18	-30	-48
6	10	-40	-25	-13	-13	-13	-5	-5	0	0	0	0	0	0
		-76	-47	-28	-22	-19	-14	-11	-6	-9	-15	-22	-36	-58
10	18	-50	-32	-16	-16	-16	-6	-6	0	0	0	0	0	0
		-93	-59	-34	-27	-24	-17	-14	-8	-11	-18	-27	-43	-70
18	30	-65	-40	-20	-20	-20	-7	-7	0	0	0	0	0	0
		-117	-73	-41	-33	-29	-20	-16	-9	-13	-21	-33	-52	-84
30	50	-80	-50	-25	-25	-25	-9	-9	0	0	0	0	0	0
		-142	-89	-50	-41	-36	-25	-20	-11	-16	-25	-39	-62	-100
50	80	-100	-60	-30	-30	-30	-10	-10	0	0	0	0	0	0
		-174	-106	-60	-49	-43	-29	-23	-13	-19	-30	-46	-74	-120
80	120	-120	-72	-36	-36	-36	-12	-12	0	0	0	0	0	0
		-207	-126	-71	-58	-51	-34	-27	-15	-22	-35	-54	-87	-140
120	180	-145	-85	-43	-43	-43	-14	-14	0	0	0	0	0	0
		-245	-148	-83	-68	-61	-39	-32	-18	-25	-40	-63	-100	-160
180	250	-170	-100	-50	-50	-50	-15	-15	0	0	0	0	0	0
		-285	-172	-96	-79	-70	-44	-35	-20	-29	-46	-72	-115	-185
250	315	-190	-110	-56	-56	-56	-17	-17	0	0	0	0	0	0
		-320	-191	-108	-88	-79	-49	-40	-23	-32	-52	-81	-130	-210
315	400	-210	-125	-62	-62	-62	-18	-18	0	0	0	0	0	0
		-350	-214	-119	-98	-87	-54	-43	-25	-36	-57	-89	-140	-230

Bore tolerances [μm]

over	up to	D10	E9	F6	F7	F8	G6	G7	H5	H6	H7	H8	H9	H10
-	3	+60	+39	+12	+16	+20	+8	+12	+4	+6	+10	+14	+25	+40
		+20	+14	+6	+6	+10	+2	+2	0	0	0	0	0	0
3	6	+78	+50	+18	+22	+28	+12	+16	+5	+8	+12	+18	+30	+48
		+30	+20	+10	+10	+10	+4	+4	0	0	0	0	0	0
6	10	+98	+61	+22	+28	+35	+14	+20	+6	+9	+15	+22	+36	+58
		+40	+25	+13	+13	+13	+5	+5	0	0	0	0	0	0
10	18	+120	+75	+27	+34	+43	+17	+24	+8	+11	+18	+27	+43	+70
		+50	+32	+16	+16	+16	+6	+6	0	0	0	0	0	0
18	30	+149	+92	+33	+41	+53	+20	+28	+9	+13	+21	+33	+52	+84
		+65	+40	+20	+20	+20	+7	+7	0	0	0	0	0	0
30	50	+180	+112	+41	+50	+64	+25	+34	+11	+16	+25	+39	+62	+100
		+80	+50	+25	+25	+25	+9	+9	0	0	0	0	0	0
50	80	+220	+134	+49	+60	+76	+29	+40	+13	+19	+30	+46	+74	+120
		+100	+60	+30	+30	+30	+10	+10	0	0	0	0	0	0
80	120	+260	+159	+58	+71	+90	+34	+47	+15	+22	+35	+54	+87	+140
		+120	+72	+36	+36	+36	+12	+12	0	0	0	0	0	0
120	180	+305	+185	+68	+83	+106	+39	+54	+18	+25	+40	+63	+100	+160
		+145	+85	+43	+43	+43	+14	+14	0	0	0	0	0	0
180	250	+335	+215	+79	+96	+122	+44	+61	+20	+29	+46	+72	+115	+185
		+170	+110	+50	+50	+50	+15	+15	0	0	0	0	0	0
250	315	+400	+240	+88	+108	+137	+49	+69	+23	+32	+52	+81	+130	+210
		+190	+110	+56	+56	+56	+17	+17	0	0	0	0	0	0
315	400	+440	+265	+98	+119	+151	+54	+75	+25	+36	+57	+89	+140	+230
		+210	+125	+62	+62	+62	+18	+18	0	0	0	0	0	0

	h11	js5	js6	j5	j6	k5	k6	m5	m6	n5	n6	p6	p5	over	up to
	0	+2	+3	+2	+4	+4	+6	+6	+8	+8	+10	+12	+10	-	3
	-60	-2	-3	-2	-2	0	0	+2	+2	+4	+4	+6	+6		
	0	+2.5	+4	+3	+6	+6	+9	+9	+12	+13	+16	+20	+17	3	6
	-75	-2.5	-4	-2	-2	+1	+1	+4	+4	+8	+8	+12	+12		
	0	+3	+4.5	+4	+7	+7	+10	+12	+15	+16	+19	+24	+21	6	10
	-90	-3	-4.5	-2	-2	+1	+1	+6	+6	+10	+10	+15	+15		
	0	+4	+5.5	+5	+8	+9	+12	+15	+18	+20	+23	+29	+26	10	18
	-110	-4	-5.5	-3	-3	+1	+1	+7	+7	+12	+12	+18	+18		
	0	+4.5	+6.5	+5	+9	+11	+15	+17	+21	+24	+28	+35	+31	18	30
	-130	-4.5	-6.5	-4	-4	+2	+2	+8	+8	+15	+15	+22	+22		
	0	+5.5	+8	+6	+11	+13	+18	+20	+25	+28	+33	+42	+37	30	50
	-160	-5.5	-8	-5	-5	+2	+2	+9	+9	+17	+17	+26	+26		
	0	+6.5	+9.5	+6	+12	+15	+21	+24	+30	+33	+39	+51	+45	50	80
	-190	-6.5	-9.5	-7	-7	+2	+2	+11	+11	+20	+20	+32	+32		
	0	+7.5	+11	+6	+13	+18	+25	+28	+35	+38	+45	+59	+52	80	120
	-220	-7.5	-11	-9	-9	+3	+3	+13	+13	+23	+23	+37	+37		
	0	+9	+12.5	+7	+14	+21	+28	+33	+40	+45	+52	+68	+61	120	180
	-250	-9	-12.5	-11	-11	+3	+3	+15	+15	+27	+27	+43	+43		
	0	+10	+14.5	+7	+16	+24	+33	+37	+46	+51	+60	+79	+70	180	250
	-290	-10	-14.5	-13	-13	+4	+4	+17	+17	+31	+31	+50	+50		
	0	+11.5	+16	+7	+16	+27	+36	+43	+52	+57	+66	+88	+79	250	315
	-320	-11.5	-16	-16	-16	+4	+4	+20	+20	+34	+34	+56	+56		
	0	+12.5	+18	+7	+18	+29	+40	+46	+57	+62	+73	+98	+87	315	400
	-360	-12.5	-18	-18	-18	+4	+4	+21	+21	+37	+37	+62	+62		

	JS7	JS6	J7	J6	K6	K7	M6	M7	N6	N7	N9	P7	P9	over	up to
	+5	+3	+4	+2	0	0	-2	-2	-4	-4	-4	-6	-6	-	3
	-5	-3	-6	-4	-6	-10	-8	-12	-10	-14	-29	-16	-31		
	+6	+4	+6	+5	+2	+3	-1	0	-5	-4	0	-8	-12	3	6
	-6	-4	-6	-3	-6	-9	-9	-12	-13	-16	-30	-20	-42		
	+7.5	+4.5	+8	+5	+2	+5	-3	0	-7	-4	0	-9	-15	6	10
	-7.5	-4.5	-7	-4	-7	-10	-12	-15	-16	-19	-36	-24	-51		
	+9	+5.5	+10	+6	+2	+6	-4	0	-9	-5	0	-11	-18	10	18
	-9	-5.5	-8	-5	-9	-12	-15	-18	-20	-23	-43	-29	-61		
	+10.5	+6.5	+12	+8	+2	+6	-4	0	-11	-7	0	-14	-22	18	30
	-10.5	-6.5	-9	-5	-11	-15	-17	-21	-24	-28	-52	-35	-74		
	+12.5	+8	+14	+10	+3	+7	-4	0	-12	-8	0	-17	-26	30	50
	-12.5	-8	-11	-6	-13	-18	-20	-25	-28	-33	-62	-42	-88		
	+15	+9.5	+18	+13	+4	+9	-5	0	-14	-9	0	-21	-32	50	80
	-15	-9.5	-12	-6	-15	-21	-24	-30	-33	-39	-74	-51	-106		
	+17.5	+11	+22	+16	+4	+10	-6	0	-16	-10	0	-24	-37	80	120
	-17.5	-11	-13	-6	-18	-25	-28	-35	-38	-45	-87	-59	-124		
	+20	+12.5	+26	+18	+4	+12	-8	0	-20	-12	0	-28	-43	120	180
	-20	-12.5	-14	-7	-21	-28	-33	-40	-45	-52	-100	-68	-143		
	+23	+14.5	+30	+22	+5	+13	-8	0	-22	-14	0	-33	-50	180	250
	-23	-14.5	-16	-7	-24	-33	-37	-46	-51	-60	-115	-79	-165		
	+26	+16	+36	+25	+5	+16	-9	0	-25	-14	0	-36	-56	250	315
	-26	-16	-16	-7	-27	-36	-41	-52	-57	-66	-130	-88	-186		
	+28.5	+18	+39	+29	+7	+17	-10	0	-26	-16	0	-41	-62	315	400
	-28.5	-18	-18	-7	-29	-40	-46	-57	-62	-73	-140	-98	-202		

11. Guide to queries

Company Date

Contact person Offer valid until

Position/department

Address

Phone Fax

E-mail

Project description

Unique demand Number of items

Series demand Items/year

Requested delivery date for: Items calendar week

New design yes/no

Cost reduction Budget Euro

Alternative to competition Competition product

Technical upgrade Previous solution

Application parameters

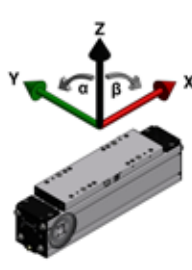
	General application parameters		Single axis	Single axis		
				X	Y	Z
	Drive type	Toothed belt Toothed belt / Ω - Drive				
		For parallel axis: axis distance [mm]				
		Mounting position: horizontal/vertical				
		Mounting angle α/β [°]				
		Travel distance/stroke [mm]				
		Velocity [m/s]				
		Acceleration [m/s ²]				
		Alternative - moving time [s]				
		Cycle time [s]				
		Repeatability [mm]				
		Required service life time [h]				
		Operating conditions (dust, splash water...)				

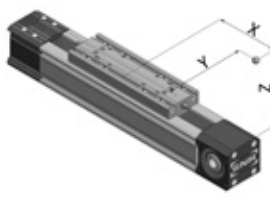
Loads						
	Masses [kg]	Position of the force application point				
		Longitudinal [mm]		Lateral [mm]	Vertical [mm]	Comments
		x_{max}	x_{min}	y	z	
Position of the center of mass						
	Forces [N]	Longitudinal [mm]		Lateral [mm]	Vertical [mm]	Comments
		x_{max}	x_{min}	y	z	
	Force direction X					
	Force direction Y					
	Force direction Z					

Please attach drawings/sketches/travel cycle for complex applications.

Comments/sketch:

12. Index

A

Accessories	56-83
Actuating element	75
Angle connection	62,63
A Standard connection	61,85
Connecting shaft	67-70
Coupling	67-70
Coupling cone	72-74
Cross connection	59
Direct connection	58
Energy chains	82
Fastening strips	56
Gantry connection	60
Grease nipple	83
Groove inserts	82
Limit switches	79-82
Motor adapter	73,74
Planetary gearbox	70-74
Plug-in shafts	64
Push-in fittings	83
Sliding blocks	57
Actuating element	25-29,75,80-81
Angle connection	62,63
A Standard connection	56,85

B

Base profile	6
Profile with guiding rails	6

C

Connection shaft	65-70
Coordinate systems	11
Coupling	65-70
Coupling cone	72-74
Coupling set for connecting shafts	67
Cover strip	35
Cover strip deflection	35
Cover strip replacement	35
Cross connections	56,59

D

Declaration of incorporation	10
Direct connection	56,58
Drive calculation	16
Drive head	6,21,22,27-29,33,38,50,78
Drive head with laterally placed grease nipples	6,33
Drive options	22,63-73
Couplings and connecting shafts	21,22,24,65-70
Force-fitted mounting of planetary gearboxes via coupling and coupling cone	21,73,74
Form-fitted mounting of the planetary gearboxes	21,72
Motor adapters	73,74
Planetary gearbox	21-24,70-74

Plug-in shaft	64,72
Driving systems	7,8
Toothed belt drive	7,8
Dynamic load capacity	12,18,49,55
Dynamic operating load	14,18,37,39-47,52,53

E

Efficiency Line Axis	38,50
Efficiency Line Axis with toothed belt drive	38
Efficiency Line Axis with toothed belt / Ω - drive	50
Energy chains	82,84,85-86
Equivalent load	12

F

Fastening strips	19,35,56,58
------------------	-------------

G

Gantry connection	56,60
Gearbox	21-24,70-74
Planetary gearboxes	21-24,70-74
Gearbox selection	15
Maximum acceleration torque	15
Maximum operation speed	15
Nominal torque on the drive	15
Grease nipple	32,33,35,83
Groove inserts	27,82
Aluminum groove insert	82
Plastic groove insert	82
Guide to queries	98
Guiding systems	8
Linear guide	8

I

Influence factors	12,31,34
Intended use	11

L

Life time	12
Nominal life time	12
Linear guide	8,12,31,33,34
Load capacity	12,18,49,55
Dynamic load capacity	12,18,49,55
Static load capacity	12,18,49,55
Lubrication	31-34
Lubricants	31
Lubrication amount	33
Lubrication intervals	34
Lubrication methods	32
Lubrication points	33

M

Main parameters	37
Maintenance and lubrication	31-36
Cover strip replacement	35
Lubricants	31
Lubrication amount	33
Lubrication intervals	34
Lubrication methods	32
Lubrication points	33
Wear part set	35
Measuring device for the toothed belt tension	8
Mounting	17-30
Design of the mounting surfaces	17,18
Drive assembly	24
Force-fitted mounting of couplings	21
Form-fitted mounting of planetary gearboxes	21
Mounting instruction	19
Mounting of inductive proximity switches for groove installation	26
Mounting of limit switches	25-29
Mounting of limit switches for linear axis AXE110Z and proximity switches for AXE160Z	27
Mounting of limit switches for linear axis AXE_Z	25
Mounting of limit switches on the drive head of linear axis AXE_A with moving profile	28
Mounting of limit switches on the profile of linear axis AXE_A with moving drive head	29
Mounting of parallel linear axis	20,24
Mounting of parallel linear axis with connecting shaft	24
Mounting of planetary gearboxes via coupling and coupling cone	22
Mounting of the gearbox flange	23
Mounting tolerances	17,18
Multi Axis Systems	84-88
Standard Multi Axis Systems	84-88

N

Nominal life time	12
-------------------	----

O

Operating temperature	11
-----------------------	----

P

Planetary gearbox	21-24,70-74
Plug-in shaft	64
Position accuracy	10
Positioning repeatability	10
Precision	14
Push-in fittings	84

R

Rigidity	6,13
Running parallelism	10

S

Safety instructions	11
Selection criteria	9
Slider unit	8,10,24,33,38
Slider unit with grease nipples on the front side	8,33
Slider unit with profile grooves	8
Sliding blocks	19,25-29,47,48,56,57
Standard Axis Systems	84-88
Standards	11
Static load capacity	12,18,49,55
Structure	38,50
Switches	25-29,75-82,84,88
Cable guiding	26,27,29,75-77,82
Mounting versions	75-79
Possible switch combinations	81,82
Switch versions	75
Technical data	80

T

Tightening torques	20
Tightening torques for drive assembly	20
Tightening torques for the couplings	20
Toothed belt clamping	7
Toothed belt tension	8
Transportation	11,17
Type code	90
Type code angle connection	62,63
Type code A standard connection	62
Type code AXE	90
Type code connecting shaft	67
Type code coupling set for connecting shafts	66
Type code cover strip	35
Type code cross connection	59
Type code direct connection	58
Type code energy chain guiding	85-86
Type code energy chain link	85-86
Type code energy chain support	85-86
Type code energy chain unit	85-86
Type code fastening strips	56
Type code force-fitted mounting of planetary gearboxes via coupling and coupling cone	72
Type code form-fitted mounting of planetary gearboxes	72
Type code gantry connection	60
Type code groove inserts	82
Type code lubrication connections	83
Type code motor adapter	71
Type code planetary gearbox	70,72
Type code plug-in shaft	64
Type code sliding blocks	57
Type code wear part sets	35

W

Wall mounting	16
Wear part sets	35

MORE INFORMATION CONCERNING OUR PRODUCTS FOR LINEAR
MOTION IS PROVIDED IN OUR CATALOGUES.



www.ntn-europe.com/documents/linear

NTN

Make the world **NAMERAKA**



DOC_L_AXE_CATT_GBa - Document non contractuel - NTN Europe copyright international - 04/24 - Photos: NTN Europe - Pedro Studio Photos

Linear Motion: AXE Linear Axis

NTN Wälzlager GmbH
Friedrich-Hagemann-Straße 66
D-33719 Bielefeld
Phone: +49 (0) 521 924 00 0
Email: linear@ntn-snr.de



This document is the exclusive property of NTN Europe. Any total or partial reproduction hereof without the prior consent of NTN Europe is strictly prohibited. Legal action may be brought against anyone breaching the terms of this paragraph.
NTN Europe shall not be held liable for any errors or omissions that may have crept into this document despite the care taken in drafting it. Due to our policy of continuous research and development, we reserve the right to make changes without notice to all or part of the products and specifications mentioned in this document.
© NTN Europe, international copyright 2024.

NTN Europe - 1 rue des Usines - 74000 Annecy
RCS ANNECY B 325 821 072 - Code APE 2815Z - Code NACE 28.15
www.ntn-europe.com

NTN

SNR

BCA
BEARINGS

BOWER

Brands of
NTN Group